

Start

1 Remove tape and packing materials

a Remove tapes

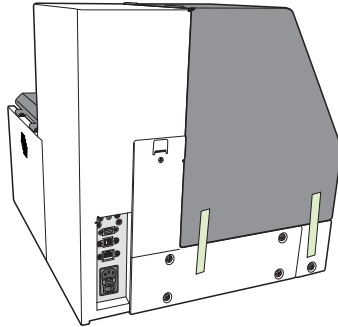
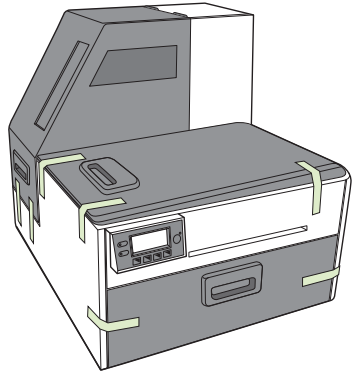
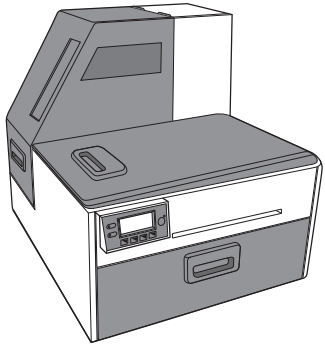

b Remove tapes and foam

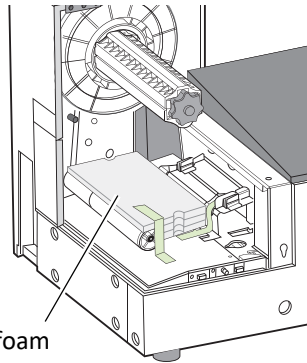
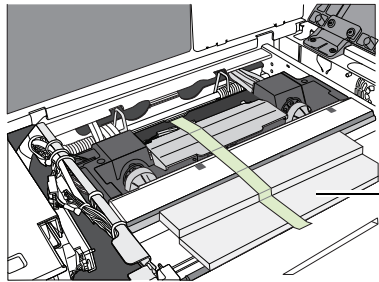

foam

c Remove cardboard

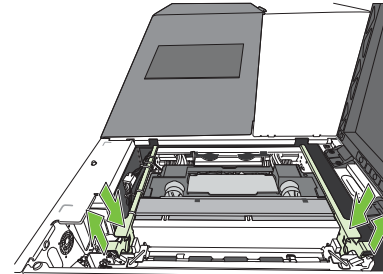

squeeze latches to open clamshell

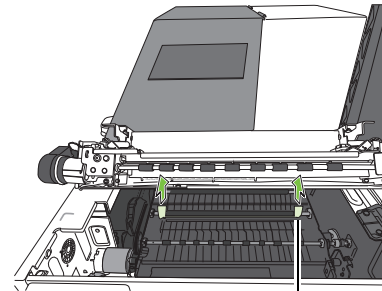

pull tabs

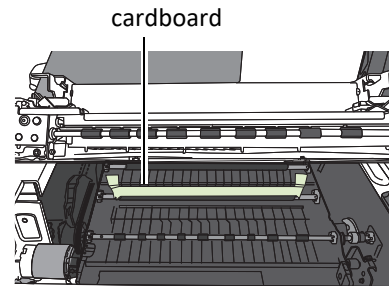

cardboard

2 Connect power

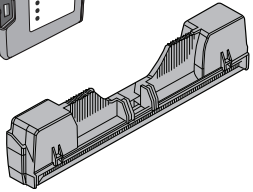
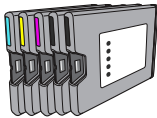
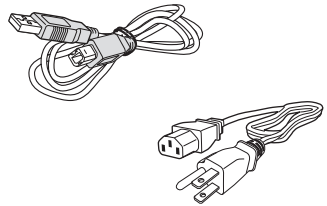
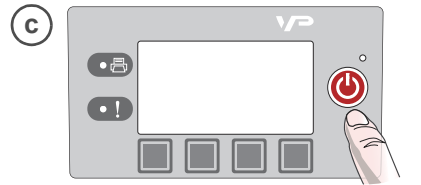
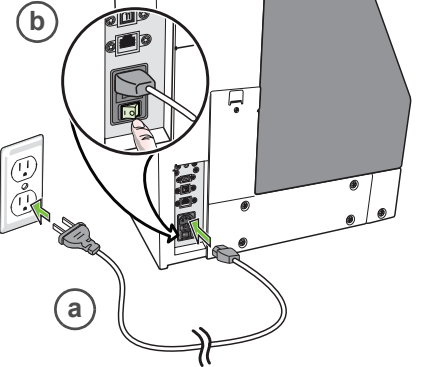

NOTE: Please ask your reseller for the printer driver software.

Choose display language

After connecting power for the first time, press Config to set the display language for the control panel.

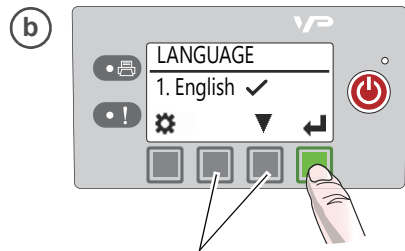
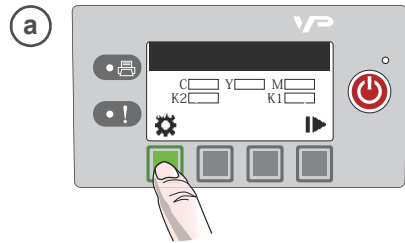

For other languages, press ▲, ▼

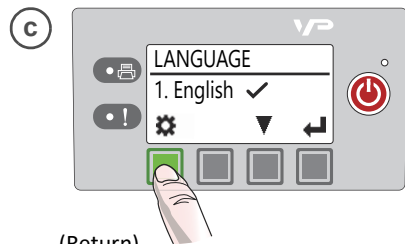

(Return)

3 Install ink cartridges

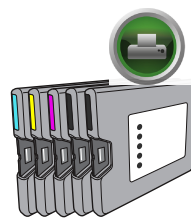
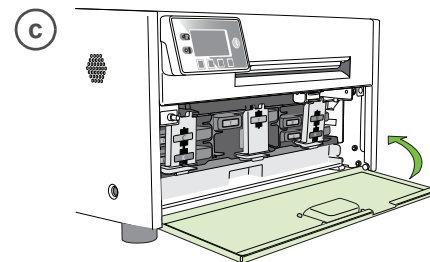
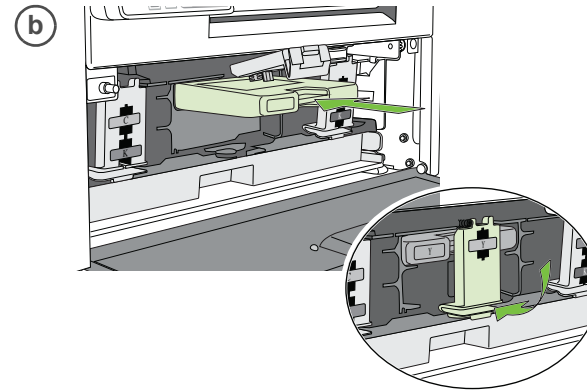
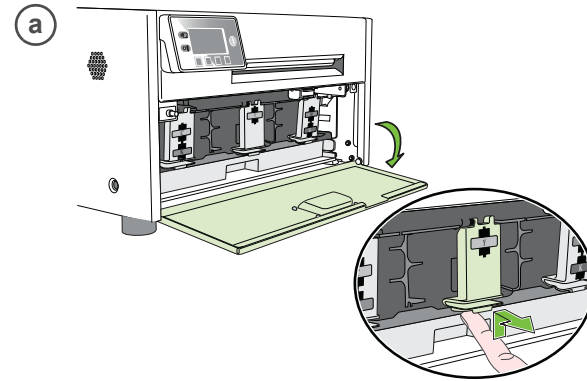

MPI

4 Install printhead

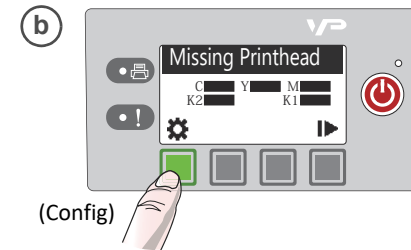
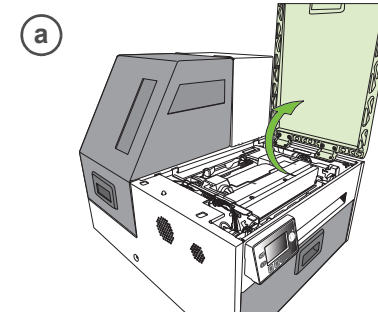

(Config)

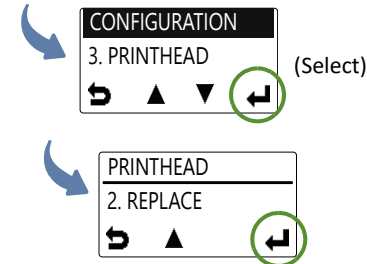

Wait for printhead latch to be released.

c Open printhead latch fully

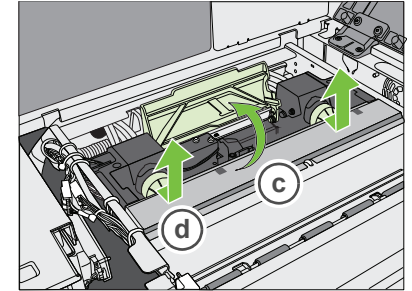

d Remove caps

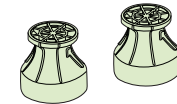

e Remove printhead from packaging

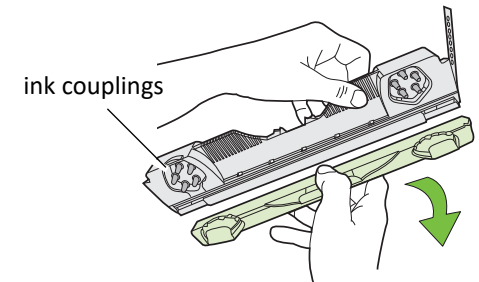

NOTE: Keep the orange cover. You will need it to cap the printhead if it is removed from the printer.

5 Load media

 Do not touch the ink couplings, electrical contacts, or nozzles.

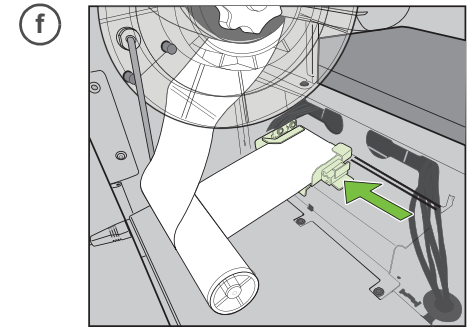
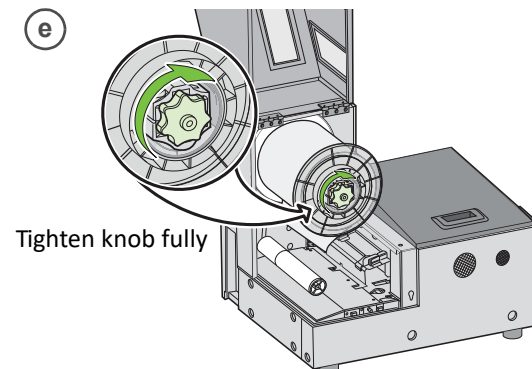
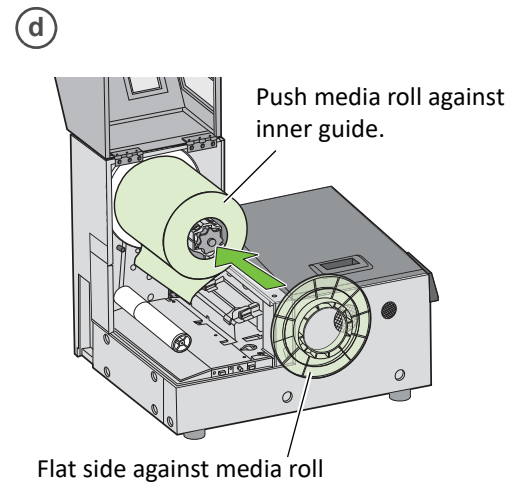
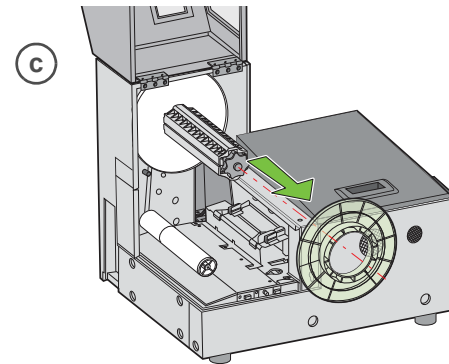
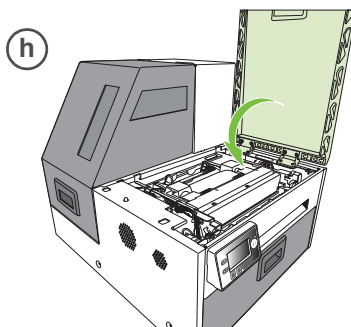
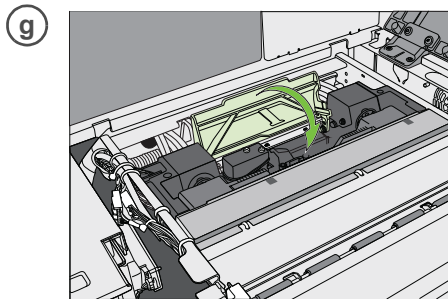
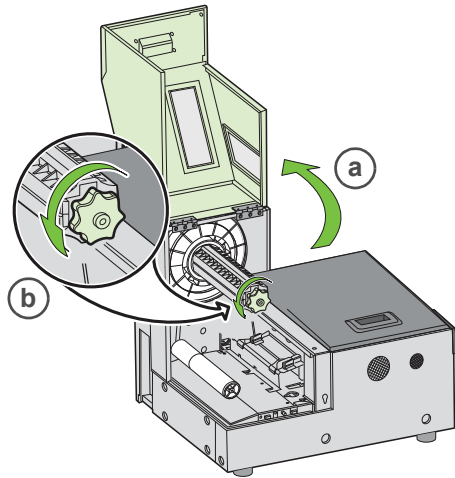
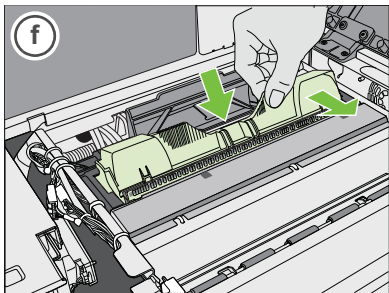
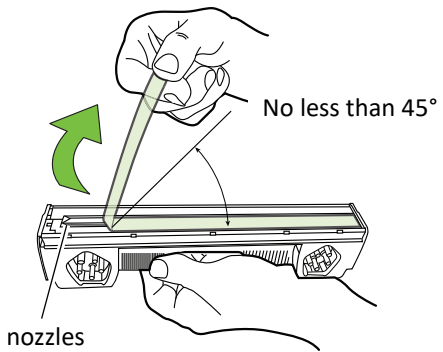
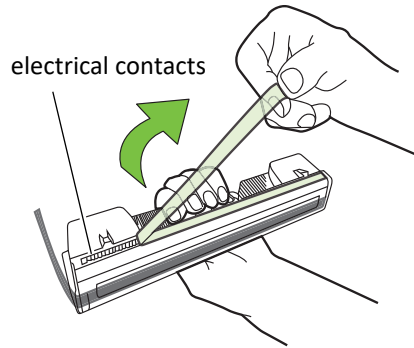

Insert media till it stops.
Wait for printer to load media.

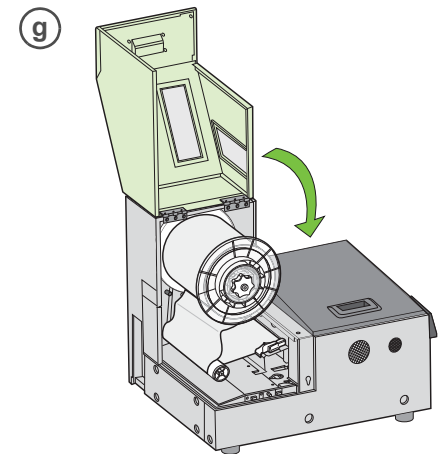

6 Print test label

Load 4" x 4" or larger labels (with inter-label gap or continuous). If using continuous stock, set Media Layout to Continuous in the EWS Diagnostics page.

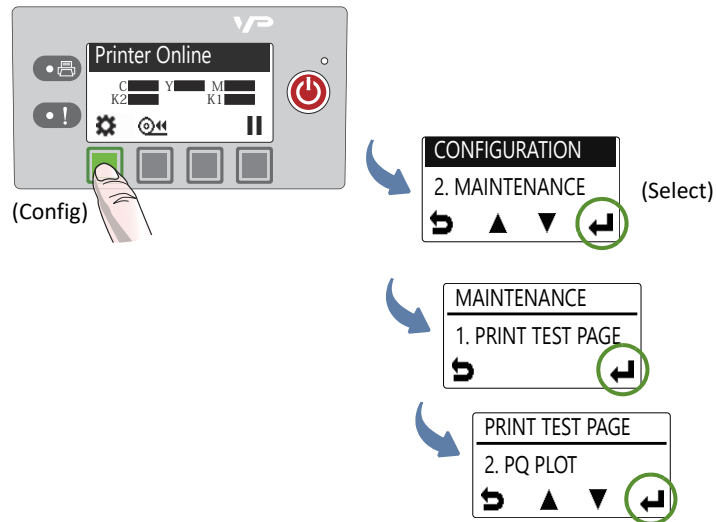

Sample PQ plot



Verify the following on the PQ plot:

- 1
 - Lines are printed in the order yellow, black, cyan, black and magenta.
 - Lines are clearly defined with no white dots or streaks.
 - Vertical dashed lines are straight.
- 2
 - Bars are printed in the order yellow, black, cyan, black and magenta.
 - Bars are clearly defined with no white dots or streaks.
 - No color mixing in the bars.
- 3
 - Text is sharp, crisp, and legible.
- 4
 - Lines are printed in the order yellow, black, cyan, black and magenta.
 - Lines are clearly defined with no white dots or streaks.



MPI

install printer driver

To connect printer to computer



(d) Connect USB cable when prompted

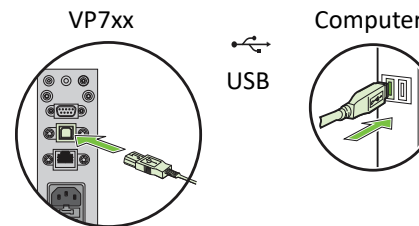

To connect printer to network

DHCP is enabled by default. If it is not available, see "Additional Networking Information".

