

PRINTRONIX®

AUTO ID

M4L Mobile Printer Administrator's Manual



Thermal Series Printers

READ THIS SOFTWARE LICENSE AGREEMENT BEFORE USING THIS PRINTER

Software License Agreement

CAREFULLY READ THE FOLLOWING TERMS AND CONDITIONS BEFORE USING THIS PRINTER. USING THIS PRINTER INDICATES YOUR ACCEPTANCE OF THESE TERMS AND CONDITIONS. IF YOU DO NOT AGREE TO THESE TERMS AND CONDITIONS, PROMPTLY RETURN THE PRINTER AND ALL ACCOMPANYING HARDWARE AND WRITTEN MATERIALS TO THE PLACE YOU OBTAINED THEM, AND YOUR MONEY WILL BE REFUNDED.

Definitions.

“Software” shall mean the digitally encoded, machine-readable data and program. The term “Software Product” includes the Software resident in the printer and its documentation. The Software Product is licensed (not sold) to you, and Printronix Auto ID Technology, Inc. either owns or licenses from other vendors who own, all copyright, trade secret, patent and other proprietary rights in the Software Product.

License.

1. Authorized Use. You agree to accept a non-exclusive license to use the Software resident in the printer solely for your own customary business or personal purposes.
2. Restrictions.
 - a. To protect the proprietary rights of Printronix Auto ID Technology, Inc., you agree to maintain the Software Product and other proprietary information concerning the typefaces in strict confidence.
 - b. You agree not to duplicate or copy the Software Product.
 - c. You shall not sublicense, sell, lease, or otherwise transfer all or any portion of the Software Product separate from the printer, without the prior written consent of Printronix Auto ID Technology, Inc.
 - d. You may not modify or prepare derivative works of the Software Product.
 - e. You may not transmit the Software Product over a network, by telephone, or electronically using any means; or reverse engineer, decompile or disassemble the Software.
 - f. You agree to keep confidential and use your best efforts to prevent and protect the contents of the Software Product from unauthorized disclosure or use.
3. Transfer. You may transfer the Software Product with the printer, but only if the recipient agrees to accept the terms and conditions of this Agreement. Your license is automatically terminated if you transfer the Software Product and printer.

Limited Software Product Warranty

Printronix Auto ID Technology, Inc. warrants that for ninety (90) days after delivery, the Software will perform in accordance with specifications published by Printronix Auto ID Technology, Inc. Printronix Auto ID Technology, Inc. does not warrant that the Software is free from all bugs, errors and omissions.

Remedy

Your exclusive remedy and the sole liability of Printronix Auto ID Technology, Inc. in connection with the Software is replacement of defective software with a copy of the same version and revision level.

Disclaimer of Warranties and Limitation of Remedies

1. THE PARTIES AGREE THAT ALL OTHER WARRANTIES, EXPRESS OR IMPLIED, INCLUDING WARRANTIES OF FITNESS FOR A PARTICULAR PURPOSE AND MERCHANTABILITY ARE EXCLUDED. Printronix Auto ID Technology, Inc. does not warrant that the functions contained in the Software will meet your requirements or that the operation of the Software will be uninterrupted or error free. Printronix Auto ID Technology, Inc. reserves the right to make changes and/or improvements in the Software without notice at any time.
2. IN NO EVENT WILL PRINTRONIX AUTO ID TECHNOLOGY, INC. BE LIABLE FOR LOST PROFITS, LOST DATA, BUSINESS INTERRUPTIONS, OR ANY OTHER DIRECT, INDIRECT, INCIDENTAL OR CONSEQUENTIAL DAMAGES ARISING OUT OF THE USE OF OR INABILITY TO USE THIS PRODUCT, EVEN IF PRINTRONIX AUTO ID TECHNOLOGY, INC. HAS BEEN ADVISED OF THE POSSIBILITY OF SUCH DAMAGES, OR ANY DAMAGES CAUSED BY THE ABUSE OR MANIPULATION OF THE SOFTWARE. SOME STATES DO NOT ALLOW THE EXCLUSION OR LIMITATION OF LIABILITY FOR CONSEQUENTIAL OR INCIDENTAL DAMAGES, SO THE ABOVE LIMITATION MAY NOT APPLY TO YOU.
3. Printronix Auto ID Technology, Inc. will not be liable for any loss or damage caused by delay in furnishing a Software Product or any other performance under this Agreement.
4. Our entire liability and your exclusive remedies for our liability of any kind (including liability for negligence except liability for personal injury caused solely by our negligence) for the Software Product covered by this Agreement and all other performance or nonperformance by us under or related to this Agreement are limited to the remedies specified by this Agreement.
5. California law governs this Agreement.

Termination of License Agreement

This License shall continue until terminated. This license may be terminated by agreement between you and Printronix Auto ID Technology, Inc. or by Printronix Auto ID Technology, Inc. if you fail to comply with the terms of this License and such failure is not corrected within thirty (30) days after notice. When this License is terminated, you shall return to the place you obtained them, the printer and all copies of the Software and documentation.

U.S. Government Restricted Rights

Use, duplication or disclosure by the Government is subject to restrictions as set forth in the Rights in Technical Data and Computer Software clause at FAR 242.227-7013, subdivision

¹ (3) (ii) or subparagraph (c) (1) (ii), as appropriate.

Further use, duplication or disclosure is subject to restrictions applicable to restricted rights software as set forth in FAR 52.227-19 (c) (2).

Acknowledgement of Terms and Conditions

YOU ACKNOWLEDGE THAT YOU HAVE READ THIS AGREEMENT, UNDERSTAND IT, AND AGREE TO BE BOUND BY ITS TERMS AND CONDITIONS. NEITHER PARTY SHALL BE BOUND BY ANY STATEMENT OR REPRESENTATION NOT CONTAINED IN THIS AGREEMENT. NO CHANGE IN THIS AGREEMENT IS EFFECTIVE UNLESS WRITTEN AND SIGNED BY PROPERLY AUTHORIZED REPRESENTATIVES OF EACH PARTY. BY USING THIS PRINTER, YOU AGREE TO ACCEPT THE TERMS AND CONDITIONS OF THIS AGREEMENT.

Trademark Acknowledgements

CSA is a registered certification mark of the Canadian Standards Association.

EIA is a registered service mark of the Electronic Industries Association.

IEEE is a registered service mark of the Institute of Electrical and Electronics Engineers, Inc.

TUV is a registered certification mark of TUV Rheinland of North America, Inc. UL is a registered certification mark of Underwriters Laboratories, Inc.

CG Triumvirate is a trademark of Agfa Corporation.

CG Triumvirate Bold Condensed font is under license from the Monotype Corporation.

Printronix and M4L are trademarks of Printronix Auto ID Technology, Inc.

ZPL and ZPL II are registered trademarks of Zebra Technologies Corporation.

Windows is a registered trademark of Microsoft Corporation.

All other trademarks are the property of their respective owners

Notice of Copyright

This document contains proprietary information protected by copyright. No part of this document may be reproduced, copied, translated, or incorporated in any other material in any form or by any means, whether manual, graphic, electronic, mechanical, or otherwise, without the written consent of Printronix Auto ID Technology, Inc.

All non-Printronix registered and/or unregistered trademarks used throughout this manual are the sole property of their respective owners.

COPYRIGHT © 2016 PRINTRONIX AUTO ID TECHNOLOGY, INC. All rights reserved.

Table of Contents

Trademark Acknowledgements	3
Notice of Copyright	3
Table of Contents	4
1 Introduction	7
Standard Features	8
General Specifications	10
Print Specifications	11
Media Specifications	11
2 Printer Overview	12
Interfaces	13
Recommended Micro SD card specification	13
LCD Display	14
3 Printer Setup	16
Installing the Belt Clip and Battery	16
Charging the Battery	16
Loading the Media	17
Loading Media in Peel-Off Mode	18
Loading Fan-fold/External Media	19
Connecting the Printer	20
Cable Communications	21
Wireless Communication with Bluetooth	21
Wireless Communication with WiFi	21
4 Power-On Utilities	22
Power-On Utilities	22
Media Sensor Calibration	22
Self-Test and Dump Mode	23
Printer Initialization	23
Self Test	23
Dump Mode	25
Printer Defaults	25
5 Configuration Utility	26
Start the Configuration Utility	26
Performing a Calibrate Sensor by Configuration Utility	27
Calibrate Sensor – Auto Calibrate	28
Calibrate Sensor - Manual Setup	28
Configuration Utility ZPL2 Emulation Menu	29
Setting AUTO.BAS by Configuration Utility	30
CPCL Emulation	30

Setting Bluetooth by Configuration Utility	30
Setting WiFi by Configuration Utility	31
6 LCD Menu Function	33
Using the LCD to Set the Printer	33
Menu Map	35
Print Setup for General	35
Print Setup for ZPL2	36
Sensor	37
Serial Comm.	38
Wireless LAN	39
Bluetooth	39
Date Time.....	39
Display	40
File Manager	40
Diagnostics.....	41
Print Config	41
Dump Mode.....	41
Battery	41
Printhead.....	41
Display Languages	41
Emulation	42
Service	42
7 Trouble Shooting	43
8 Maintenance	46
A Contact Information	47
Printronix Customer Support Center.....	47
B Notices.....	49
Communication Statements	51
Software License Agreement	54



1 *Introduction*

The M4L is a comfortable, light-weight printer capable of working with any mobile receipt printing application where you need quick, simple receipts on demand. Our M4L is designed for a rough life, inside the IP54-rated environmental case to resist dust and water and with its rubber over-mold design prepared to take up to a five foot fall and keep printing. These small and light printers can be worn comfortably for a full shift, without interfering with the user's tasks. Use USB, Bluetooth, optional 802.11 b/g/n Wireless or serial to connect to a mobile computer or even a smart phone and produce clear easy-to-read receipts hour after hour

To print label formats, please refer to the instructions provided with your labeling software; if you need to write the custom programs, please refer to the ZPL/CPCL programming manual that can be found on on PRINTRONIX website at <http://www.PrintronixAutoID.com>.

Applications

- Portable point of sale
- Retail item marking, markdowns, shelf labeling & shelf talkers
- Labels for shipping & receiving
- Inventory control
- Cross-docking
- Pick, pack & apply operations
- Print pick tickets
- Logistics receipts

Standard Features

Your M4L offers the following standard features:

Standard Feature
Direct thermal printing
Black Mark reflective sensor (center position, black mark in back side)
Gap transmissive sensor (Fixed, center of offset 2.75 mm to right from center) 203 Print Density
203 Print Density
Cover open sensor
Label Taken sensor
LCD Control Panel Display
4 operation buttons (On/off, menu, info, and feed)
2 LEDs for printer status and battery status
USB 2.0 (full speed) interface
Class 2 Bluetooth 2.1 module
32 MB SDRAM memory
16 MB FLASH memory
Micro SD card reader for memory expansion up to SDHC 4G (max.)
DC 7.2V/5800 mAh Li-ion rechargeable battery
Real Time Clock
Powerful 32 bit 200 MHz RISC processor
Zebra® CPCL and Zebra® ZPL emulation languages support
Internal 8 alpha-numeric bitmap fonts
Internal Monotype Imaging® true type font engine with one CG Triumvirate Bold Condensed scalable font
Fonts and bar codes can be printed in any one of the four directions (0, 90,180, 270 degree)
Downloadable fonts from PC to printer memory. If a font is called out in the print job and does not exist in the printer, the workaround is to download a similar truetype font and rename in the file system to match CPCL command font.
Downloadable firmware upgrades

Bar code, Graphics/image Printing		
Supported bar code		Supported image
1D bar code	2D bar code	BITMAP BMP PCX
Code 128 subsets A, B, C; Code 128UCC; EAN 128; Interleave 2 of 5; Code 39; Code 93; EAN-13; EAN-8; Codabar; POSTNET; UPC-A; UPC-E; EAN and UPC 2(5) digits; MSI; PLESSEY; ITF-14; EAN14; Code 11; PLANET; LOGMARS	CODABLOCK F mode; DataMatrix, Maxicode, PDF-417; Aztec; MicroPDF417; QR code; RSS Barcode (GS1 Databar); Code 49	

Code page		
Codepage 437 (English-US)	Codepage 950 (Traditional Chinese)	ISO-8859-1: Latin-1 (Western European)
Codepage 737 (Greek)	Codepage 936 (Simplified Chinese)	ISO-8859-2: Latin-2 (Central European)
Codepage 850 (Latin-1)	Codepage 932 (Japanese)	ISO-8859-3: Latin-3 (South European)
Codepage 852 (Latin-2)	Codepage 949 (Korean)	ISO-8859-4: Latin-4 (North European)
Codepage 857 (Turkish)	Codepage 1250 (Latin-2)	ISO-8859-5: Cyrillic
Codepage 860 (Portuguese)	Codepage 1251 (Cyrillic)	ISO-8859-6: Arabic
Codepage 861 (Icelandic)	Codepage 1252 (Latin-1)	ISO-8859-7: Greek
Codepage 862 Hebrew)	Codepage 1253 (Greek)	ISO-8859-8: Hebrew
Codepage 863 (French Canadian)	Codepage 1254 (Turkish)	ISO-8859-9: Turkish
Codepage 864 (Arabic)	Codepage 1255 (Hebrew)	ISO-8859-10: Nordic
Codepage 865 (Nordic)	Codepage 1256 (Arabic)	ISO-8859-15: Latin-9
Codepage 866 (Russian)	Codepage 1257 (Baltic)	UTF-8
Codepage 869 (Greek 2)	Codepage 1258 (Vietnam)	

General Specifications

General Specifications										
Physical dimensions	6.3in (160mm) W x 7.54in (191.6mm) H x 3.11in (79mm) D									
Mechanism	Plastic with rubber over molded									
Weight	2.083lb (0.945kg) w/o Battery; 2.43lb (1.1kg) with Battery									
Power	Single Unit Charger (optional) Input: AC 100-240V Output: DC 12V 1A									
Environmental condition	Operation: 14 to 122°F (-10 to 50°C) Storage: -40 to 140°F (-40 to 60°C) Relative humidity: 10 ~ 90% non-condensing IP54 w/ IP54-rated environmental case Drop 5ft (1.5m) Drop 6.5ft (1.8m) w/ IP54-rated environmental case									
Battery Spec	Charging time: ~5 hr (Single Unit Charger), ~2 hr (Bay Charger) Standby mode (Bluetooth): up to 32 hr Standby mode (Wi-Fi): up to 18 hr Printing: one label per 2 minutes, <table border="1" data-bbox="604 940 1218 1062"> <thead> <tr> <th>Condition</th> <th>Endurance (hr)</th> <th>4" x 6" Labels</th> </tr> </thead> <tbody> <tr> <td>Density 3</td> <td>26</td> <td>780</td> </tr> <tr> <td>Density 8</td> <td>21</td> <td>650</td> </tr> </tbody> </table>	Condition	Endurance (hr)	4" x 6" Labels	Density 3	26	780	Density 8	21	650
Condition	Endurance (hr)	4" x 6" Labels								
Density 3	26	780								
Density 8	21	650								
Charging capability	<u>Internal charging capability (battery-in)</u> Single Unit Charger (optional) <u>External charging capability (battery-out)</u> Charging stations (4 bay or single bay) (optional)									

Print Specifications

Print Specifications	
Printhead resolution (dots per inch/mm)	203 dots/inch (8 dots/mm)
Printing method	Direct thermal
Dot size (width x length)	0.125 x 0.125 mm (1 mm = 8 dots)
Print speed (inches per second)	Max. 4 ips (100 mm/sec) 2,3 ips for Peel-Off mode
Max. print width	4.09" (104 mm)
Max. print length	90" (2286 mm)
Printout bias	Vertical: 1 mm max. Horizontal: 1 mm max.

Media Specifications

Media Specifications	
Media roll capacity	Max. 2.65" (67.3 mm) OD
Media core diameter	0.5 ~ 1" (12.7 mm ~ 25.4 mm) ID core
Media type	Continuous, die-cut, gap/black mark, External fan- fold, receipt
Media wound type	Outside wound
Media width	2" ~ 4.41" (50.8 mm ~ 112 mm)
Media thickness	0.0022"~0.0065" (0.055 mm ~ 0.165 mm)
	0.5in Hub = 2in to 4.41in (50.8mm to 112mm) ¹
	0.75in Hub = 2in to 4.34in (50.8mm to 110.3mm)
	1.00in Hub = 2in to 4.34in (50.8mm to 110.3mm)
Label length	0.500"~90" (12.7 mm ~ 2286 mm)
Label length (peel mode)	1" ~ 6" (25.4 ~ 152.4 mm)
External fan-fold media	Stack height: 2.75" (70 mm) Page length: 6" ~ 12" (152 mm ~ 305 mm)
Black Mark	Min. 0.3150" (8 mm) (W) x 0.0785" (2 mm) (H)
Gap height	Min. 0.0785" (2 mm)

Note 1: **0.5in Hub is located under 0.75 to 1.00in Hub adapters. Remove Phillips head screw and nut from each Media Holder**

2 *Printer Overview*

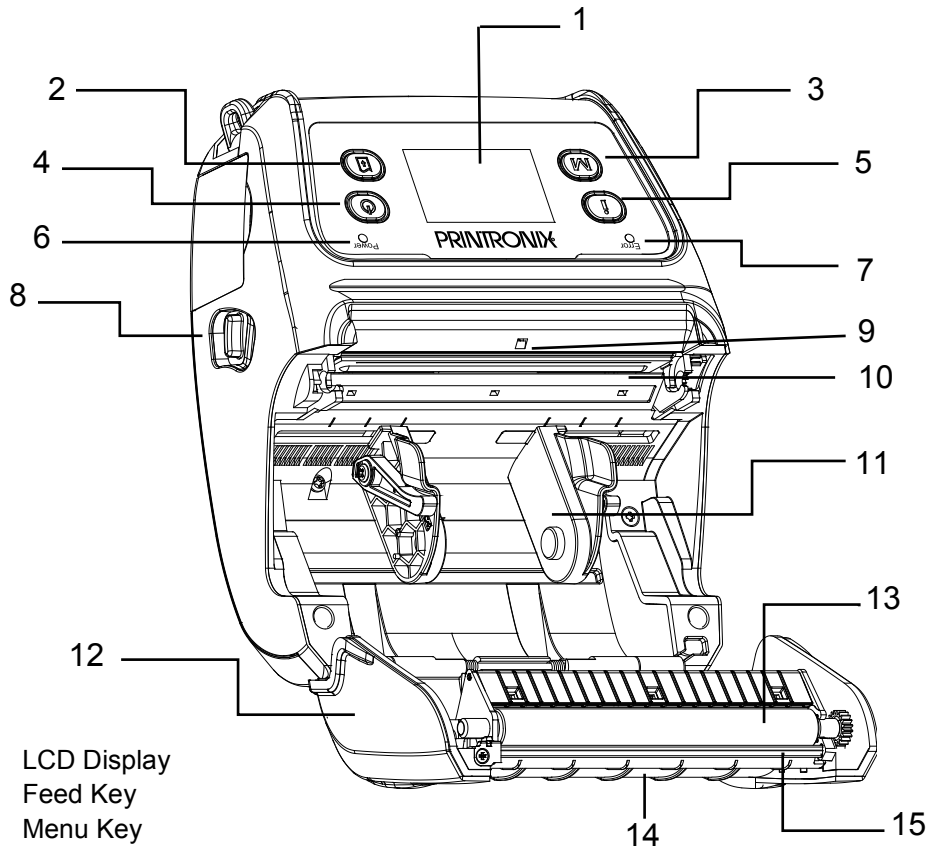

1. LCD Display
2. Feed Key
3. Menu Key
4. Power On/Off Key
5. Info Setting Key
6. Battery Status Indicator
7. Error/Power Indicator
8. Media Cover Release Latch
9. Peel-Off Sensor
10. Printhead
11. Media Holder
12. Media Cover
13. Platen Roller
14. Label Peel Cover
15. Tear/Peel Bar

Interfaces

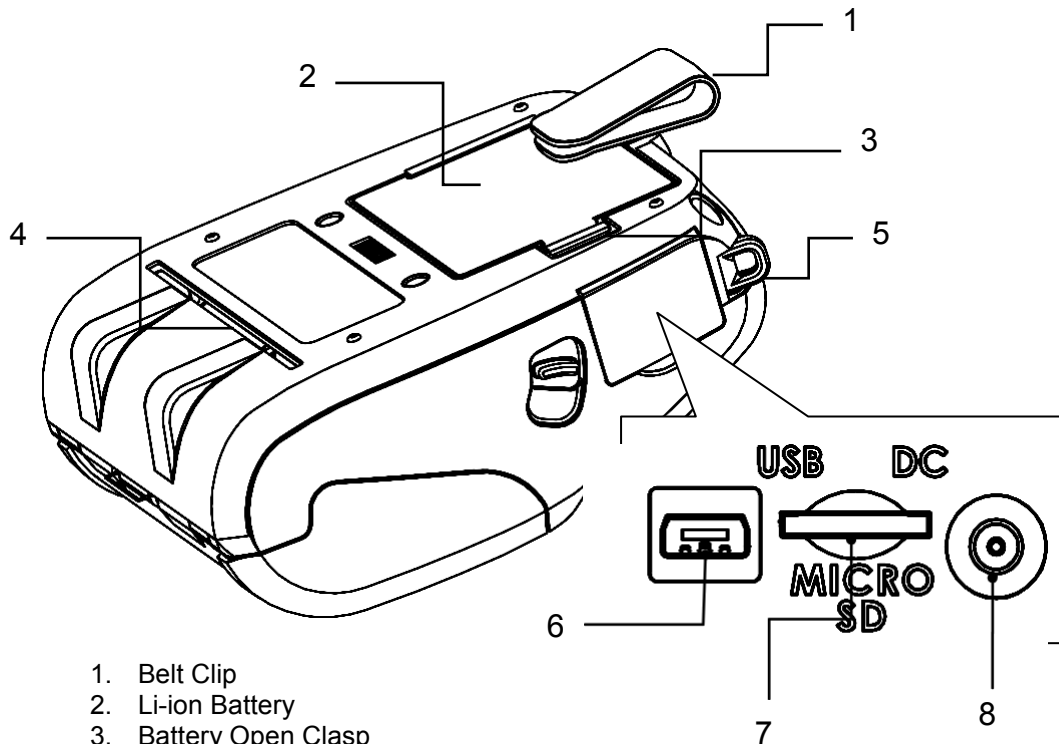







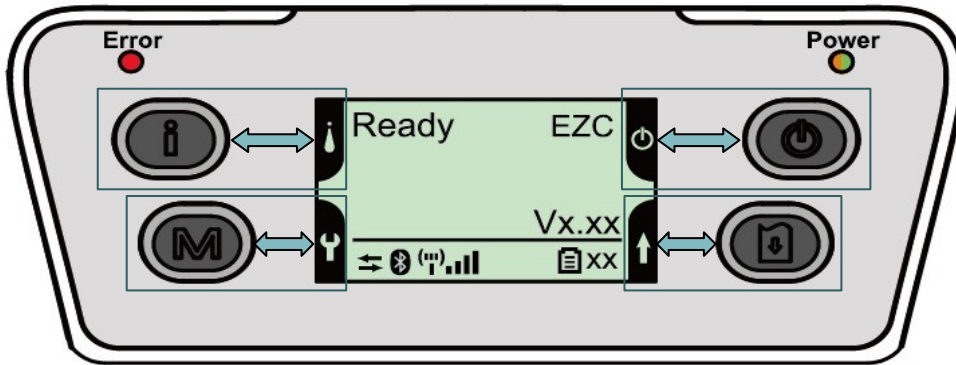

1. Belt Clip
2. Li-ion Battery
3. Battery Open Clasp
4. External Label Entrance Slot
5. Hanger for Shoulder Strap (2)
6. USB Interface
7. Micro SD Card Socket
8. Power Jack (used for Charger)

Recommended Micro SD card specification

SD card spec	SD card capacity	Approved SD card manufacturer
V1.0, V1.1	MicroSD 128 MB	Transcend, Panasonic
V1.0, V1.1	MicroSD 256 MB	Transcend, Panasonic
V1.0, V1.1	MicroSD 512 MB	Transcend, Panasonic
V1.0, V1.1	MicroSD 1 GB	Transcend, Panasonic
V2.0 SDHC CLASS 6	MicroSD 4 GB	Transcend
- The DOS FAT file system is supported for the SD card.		
- Folders/files stored in the SD card should be in the 8.3 filename format		

LCD Display

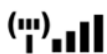

Keys	Function	
	<ul style="list-style-type: none"> - Display the printer information - Key for setting LCD configuration menu 	
	<ul style="list-style-type: none"> - Enter the printer configuration menu - Key for setting LCD configuration menu 	
	<ul style="list-style-type: none"> - Press and hold for 2-3 seconds to turn on the printer - Press and hold for 2-3 seconds to turn off the printer - Key for setting LCD configuration menu 	
	<ul style="list-style-type: none"> - Ready status: Feed one label - Printing status: Pause the print job - Key for setting LCD configuration menu 	
LEDs	Status	Indication
Error	Off	Printer is ready
	Red (solid)	<ul style="list-style-type: none"> - Media cover is open - Out of memory - Clean data - Printer is busy
	Red (blinking)	<ul style="list-style-type: none"> - No paper - Paper jam
Power	Off	Printer power is turned off
	Green (solid)	<ul style="list-style-type: none"> - Printer power is turned on - Battery is fully charged
	Green (blinking)	Low battery
	Amber (solid)	Battery is charging
LCD	Indication	
	Printer has been connected with cable	
	Bluetooth devices have been paired	
	Wi-Fi device has been connected	
	Battery capacity %	



3 *Printer Setup*

Installing the Belt Clip and Battery



Insert the Belt Clip first

Insert the left side to install the battery on the underside of the printer, and then push the right side of the battery down until the clasp locks down in place.

Battery Safety Warning:

DO NOT throw the battery in fire.

DO NOT short circuit the contacts.

DO NOT disassemble the battery.

DO NOT throw the battery in municipal waste

CAUTION: Danger of explosion if battery is incorrectly replaced. Replace only with the same or equivalent type recommended by the manufacturer. Dispose of used batteries according to the manufacturer's instructions

Charging the Battery

IMPORTANT Before using the printer, make sure the battery is fully charged. It takes ~ 5 hours to charge the battery using the Single Unit Charger (battery installed in printer) or ~ 1 hour using an External Charging Station (4 bay or single bay). The lifetime of the battery is ~ 300 charge/discharge cycles.



Charging Instructions:

- *Single Unit Charger only:* After installing the battery into the printer, open the interface cover and plug the Single Unit Charger power cord into the printer power jack.
- Plug the Charger into a compatible AC power outlet.
- Switch OFF printer power prior to plugging the Single Unit Charger power cord into the printer power jack.
- Do not remove the battery from the printer while it is charging or you will need to re-plug the charger into the power outlet.
- When the battery is charging, the color of the Power LED Indicator is solid amber.

- The battery is fully charged when the Power LED Indicator turns from amber to green.

Loading the Media



Open

the media cover release latch.

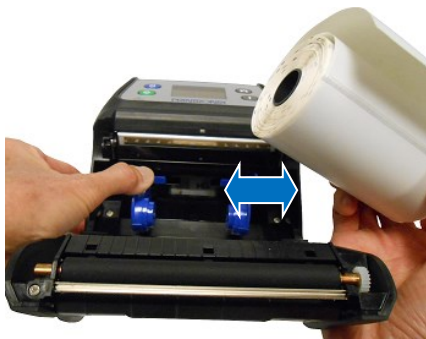

Pull the media holders apart far enough to fit the width of the label roll you are installing



Place the roll, printing side face-out, between the media holders and insert hubs into the core. Pull out enough paper above the printhead.



Press down on both sides of the media cover to ensure it is closed correctly.

NOTE: Calibrate the gap/black mark sensor when changing media using the Configuration Utility – Printer Function – Calibrate Sensor or the Power-On Utilities.

Loading Media in Peel-Off Mode



Load Media as defined in **Loading the Media** section on previous page



Remove 1 ~ 2 die cut labels from the liner



Press down on both sides of the media cover to ensure it is closed correctly.



Route the liner under the label peel cover as shown



Pull the liner tightly



Push the label peel cover toward the front of the printer until it covers the plate roller



Press down on the label peel cover to lock it in place

NOTE: Calibrate the gap/black mark sensor when changing media using the Configuration Utility – Printer Function – Calibrate Sensor or the Power-On Utilities.

Loading Fan-fold/External Media

Open the printer media cover by pressing down on the media cover release latch.

Pull the media holders apart far enough to fit the width of the Fan-fold media you are installing



Install Media Core that is the width of your media to secure the media holders in place

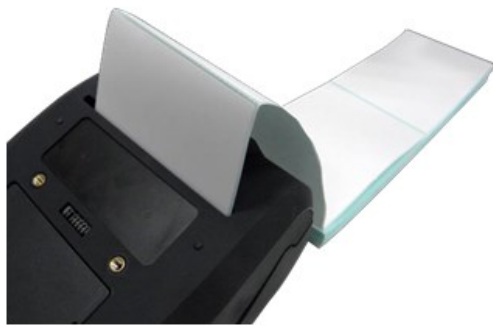

Route the media, printing side out, through the bottom external label slot



Press down on both sides of the media cover to make sure it is closed correctly

NOTE: Calibrate the gap/black mark sensor when changing media using the Configuration Utility – Printer Function – Calibrate Sensor or the Power-On Utilities.

Connecting the Printer

The printer must establish communication with a host terminal which sends the data to be printed. There are three ways to connect the M4L series:

- By an USB cable between the printer and its host terminal
- By a Bluetooth short-range radio if Bluetooth is installed and enabled.
- By a Wireless LAN per 802.11 b/g/n (Option)

Cable Communications



Open the interface cover and connect the printer to the computer/smart phone (host terminal) with USB cable (USB to USB or USB to RS-232).

Wireless Communication with Bluetooth

- Power on the printer
- Open the Bluetooth device for host terminal to scan for printer's Bluetooth device.
- Connect the Bluetooth devices.
- The Bluetooth icon will display in the LCD panel if devices have been paired.

Printer Bluetooth default	
Address	You can find this info from configuration (self-test) page, Please refer to Power On Utilities section for how to print the self-test.
Name	BT-SPP
PIN	0000

Note: Please refer to “Setting Bluetooth by Configuration Utility” on page 30 to change the name and PIN by Configuration Utility or refer to “Bluetooth” on page 39 to change the name and PIN directly.

Wireless Communication with WiFi







You should set the WLAN settings via the USB cable when first setting up the printer. Please refer to “Setting WiFi by Configuration Utility” on page 31 to set up the WiFi module. Please refer to “Wireless LAN” on page 39 to set up the WLAN settings.



4 Power-On Utilities

There are three power-on utilities to set up and test printer hardware. These utilities are activated by pressing the FEED key then turning on the printer power key simultaneously and releasing the FEED key when the desired utility function displays on the LCD panel to initiate that utility.

Power-On Utilities

Use the following steps to initiate different power-on utilities:



1. Turn off the printer power using the power key .
2. Press and hold the FEED key  then while still pressing the FEED key press and hold down the power key .
3. Release the power key  when the “Error” LED turns red.
4. At this time continue to press down on the FEED key .
5. After the printer beeps twice, wait until the desired utility displays on the LCD and then release the FEED key  to initiate that utility. The order that the utilities appear on the LCD are described below:

Power On Utilities	The LCD will change as follows:		
LCD	<div style="border: 1px solid black; padding: 5px; text-align: center;">Calibrate.....</div> <p>(5 dots)</p>	 <div style="border: 1px solid black; padding: 5px; text-align: center;">Self Test.....</div> <p>(5 dots)</p>	 <div style="border: 1px solid black; padding: 5px; text-align: center;">Initialize.....</div> <p>(5 dots)</p>
Release Feed key  for different functions	Media sensor calibration	Media sensor calibration, self-test and dump mode	Printer initialization



Media Sensor Calibration

IMPORTANT Before doing Media Sensor Calibration, verify the last selected Media Sensor type still matches the media installed in the printer (Gap, Black Mark or Continuous). You can check this by doing a “Get” in the Configuration Utility or by doing an Auto Calibrate as described in “Calibrate Sensor – Auto Calibrate” on page 28.

Use the following steps to calibrate the media sensor:

1. Turn off the printer using the Power key .
2. Press and hold down the Feed key  then, while still holding down the Feed key, press and

hold down the Power key .







3. Release the Power key  when the Error LED turns red continuing to hold the Feed key .
4. When the printer beeps twice release the Feed key . The LCD will display “Calibrating.....”.

The printer will move media, calibrate the gap/black mark sensor sensitivity and then stop with “Ready” displayed on the LCD.

NOTE: If the Feed key is held down after the printer beeps twice, with “Self Test” displayed, it will perform a Calibrate followed by a Self Test where it prints a Configuration Page and then ends in Dump mode.

Self-Test and Dump Mode

Use the following steps to perform Self-Test:







1. Turn off the printer using the Power key .
2. Press and hold down the Feed key  then, while still holding down the Feed key, press and hold down the Power key .
3. Release the Power key  when the Error LED turns red continuing to hold the Feed key .
4. When the printer beeps twice wait until “Self Test” displays on the LCD then release Feed key .

The printer will calibrate the sensor, print a Configuration Page of its internal settings and then enter Dump mode.

NOTE: To exit Dump mode and return the printer back to normal print mode, turn off/on the printer power or press the Feed key. The LCD will display “Ready”.

Printer Initialization

Printer initialization is used to clear DRAM and restore printer settings to defaults. Use the following steps to perform printer initialization:

1. Turn off the printer using the Power key .
2. Press and hold down the Feed key  then, while still holding down the Feed key, press and hold down the Power key .
3. Release the Power key  when the Error LED turns red continuing to hold the Feed key .
4. When the printer beeps twice wait until “Initialize” displays then release the Feed key .
5. The LCD will display “Initializing.....” followed by “Ready”.

The printer will restore printer settings to defaults (see section “Printer Defaults” on page 25).

Self Test

Printer will print the Configuration Page after media sensor calibration. Self-test printout can be used to verify printer configurations and available memory space. The printhead test pattern can verify if any printhead heater elements (dots) are damaged.

NOTE: The Self-test printout requires 4" paper/label width.

```

PRINTER INFO.
M4L Version: 1.54 EZC _____ Printer Model name & Main Board firmware version
SERIAL NO.: _____ Printer serial number
MILAGE(m): 607 _____ Printed mileage
CHECKSUM: 0831B281 TCF _____ Main Board firmware checksum
SERIAL PORT: 9600,N,8,1 _____ Serial port setting
CODE PAGE: 850 _____ Code page
COUNTRY CODE: 001 _____ Country code
SPEED: 2 INCH _____ Print speed
DENSITY: 8.0 _____ Print darkness
SIZE: 4.00 , 4.00 _____ Label size (width, height)
GAP: 0.00 , 0.00 _____ Gap/Black mark (vertical gap, offset)
TRANSPARENCE: 3 _____ Sensor sensitivity
VOLTAGE: 8.21 V _____ Battery voltage
TEMPERATURE: 26 °C _____ Printhead temperature
RESISTANCE: 176 ohm _____ Printhead average resistance
BAD DOT(S): 0 _____ Bad dots of Printhead
*****
BT ADDRESS: 00190EA07A68
BT NAME: BT-SPP
BT PIN CODE: 0000
BT SOFTWARE:
BT SECURITY: 2
*****
WLAN APP VERSION: 3.3.3.4
WLAN MAC ADDRESS: 00-1D-C9-90-F8-8E
WLAN MODE: INFRASTRUCTURE
WLAN SSID: SUDVT_Synboll
WLAN DHCP ENABLED: NO
WLAN IP ADDRESS: 10.224.5.13

WLAN SUBNET MASK: 255.255.0.0
WLAN DEFAULT GATEWAY: 10.224.1.254
WLAN PRINTER NAME: PS- 90F88E
*****
FILE LIST:
DRAM FILE:          0 FILE(S)

FLASH FILE:         0 FILE(S)

PHYSICAL DRAM:      32768 KBYTES
AVAILABLE DRAM:     2048 KBYTES FREE
PHYSICAL FLASH:     16384 KBYTES
AVAILABLE FLASH:    14336 KBYTES FREE
END OF FILE LIST
*****

```

Bluetooth settings information

WiFi settings information

File management information

Printhead test pattern

Dump Mode

Printer will enter dump mode after printing Configuration Page. In dump mode, all characters will be printed in 2 columns as shown. The left side characters are received from your system and right side data are the corresponding hexadecimal value of the characters. It allows users or engineers to verify and debug the program.

```

ASCII Data →
SPEED 2.0      53 50 46 45 44 20 32 2E 30 0D
DENSITY 8     0A 44 45 4E 53 49 54 59 20 38
SET PEEL      0D 0A 53 45 54 20 50 45 45 4C
OFF DIRE      29 4F 46 46 0D 0A 44 49 52 45
CTION 0 0     43 54 49 4F 4E 20 30 0D 0A 47
AP 3.00 mm    41 50 20 33 2E 30 30 20 6D 6D
.0.00 mm      2C 30 2E 30 30 20 6D 6D 0D 0A
REFERENCE     52 45 46 45 52 45 4E 43 45 20
0.0 SET C     30 2C 30 0D 0A 53 45 54 20 43
UTTER OFF     55 54 54 45 52 20 4F 46 46 0D
SIZE 100.     0A 53 45 5A 45 20 31 30 30 2E
02 mm.65.0   30 32 20 6D 6D 2C 36 35 2E 30
4 mm CLS      34 20 6D 6D 0D 0A 43 4C 53 0D
BARCODE 1     0A 42 41 52 43 4F 44 45 20 31
44.149."39    34 34 2C 31 34 39 2C 22 33 39
".120."1.0.   22 2C 31 32 30 2C 31 2C 30 2C
2.6."57114    32 2C 36 2C 22 35 37 31 31 34
38T" PRIN     33 38 54 22 0D 0A 50 52 49 4E
T 1.1 SPE     54 20 31 2C 31 0D 0A 53 50 45
ED 2.0 DE     45 44 20 32 2E 30 0D 0A 44 45
NSITY 8 S     4E 53 49 54 59 20 38 0D 0A 53

ET PEEL OF    45 54 20 50 45 45 4C 20 4F 46
F DIRECTI     46 0D 0A 44 49 52 45 43 54 49
ON 0 GAP      4F 4E 20 30 0D 0A 47 41 50 20
3.00 mm.0.    33 2E 30 30 20 6D 6D 2C 39 2E
00 mm REF     30 30 20 6D 6D 0D 0A 52 45 46
ERENCE 0.0    45 52 45 4E 43 45 20 30 2C 30
SET CUTT      0D 0A 53 45 54 20 43 55 54 54
ER OFF SI     45 52 20 4F 46 46 0D 0A 53 49
ZE 100.02     5A 45 20 31 30 30 2E 30 32 20
mm.65.04 m    6D 6D 2C 36 35 2E 30 34 20 6D
m CLS BA      6D 6D 0A 43 4C 53 0D 0A 42 41
RCODE 144.    52 43 4F 44 45 20 31 34 34 2C
149."39".1    31 34 39 2C 22 33 39 22 2C 31
20."1.0.2.6   32 30 2C 31 2C 30 2C 32 2C 36
;"5711438T    2C 22 35 37 31 31 34 33 38 54
. PRINT 1     22 0D 0A 50 52 49 4E 54 20 31
.1            2C 31 0D 0A
  
```

Hex decimal data related to left column of ASCII data ←

IMPORTANT Dump mode requires 4" paper/label width.

Exit Dump mode by turning off / on the power or by pressing the FEED key. The LCD will show "Ready" for normal printing operation.

Printer Defaults

Printer configuration will be restored to defaults as below after initialization.

Parameter	Default setting
Speed	50.8 mm/sec (2 ips)
Density	8
Media Width	4" (101.5 mm)
Media Height	4" (101.5 mm)
Sensor Type	Gap sensor
Print Direction	0
Reference Point	0,0 (upper left corner)
Gap Offset	0
Post-Print Action	Tear mode
Serial Port Settings	9600 bps, none parity, 8 data bits, 1 stop bit
Code Page	850
Country Code	001
Clear Flash Memory	No

NOTE: When printer initialization is done, calibrate the gap or black mark sensor before printing or attempting any Self tests.

5 Configuration Utility

The M4L Configuration Utility is an integrated tool incorporating features that enable you to explore a printer's settings/status; change a printer's settings; download graphics, fonts and firmware; create a printer bitmap font; and send additional commands to a printer. With the aid of this powerful tool, you can review printer status and setting in an instant, which makes it much easier to troubleshoot problems and other issues.

Start the Configuration Utility

There are four features (Printer Configuration, File Manager, Bitmap Font Manager, Command Tool) included in the Configuration Utility.

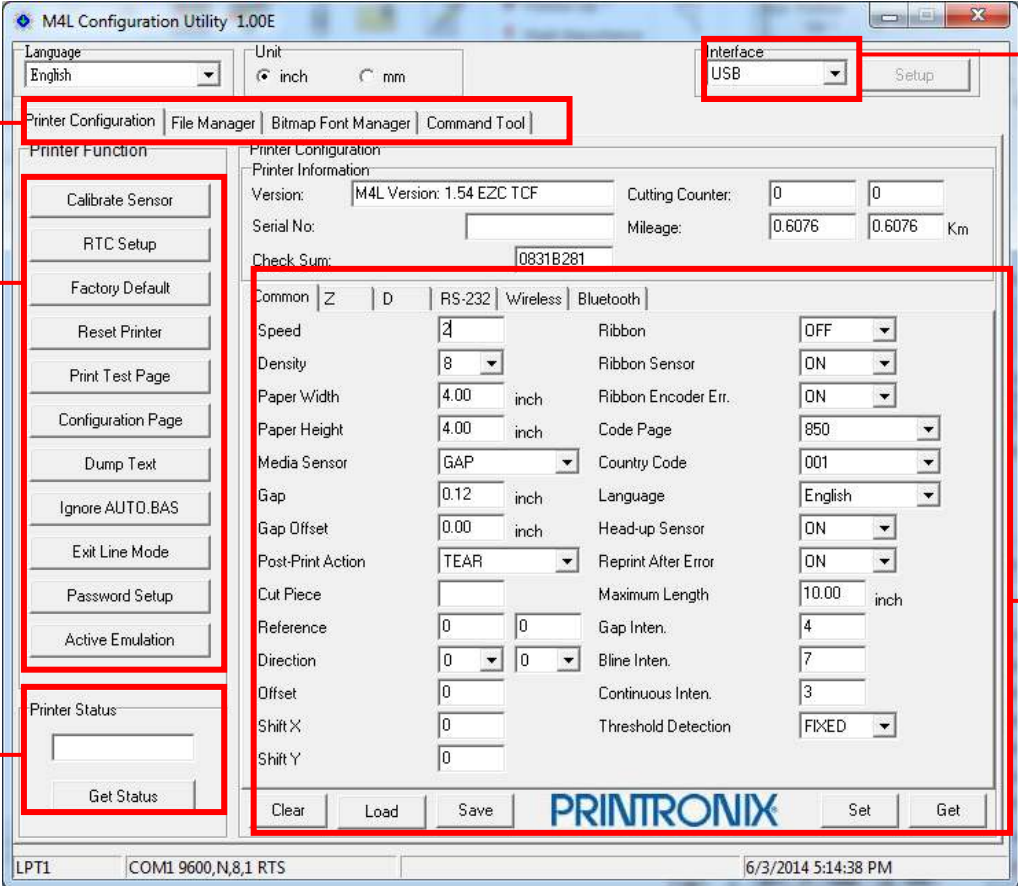

The screenshot shows the M4L Configuration Utility 1.00E window. Red boxes and labels highlight the following elements:

- Features Tab:** A box around the top navigation tabs: Printer Configuration, File Manager, Bitmap Font Manager, and Command Tool.
- Printer Function:** A box around the left sidebar containing buttons for Calibrate Sensor, RTC Setup, Factory Default, Reset Printer, Print Test Page, Configuration Page, Dump Text, Ignore AUTO.BAS, Exit Line Mode, Password Setup, and Active Emulation.
- Printer Status:** A box around the bottom-left section containing a 'Printer Status' label and a 'Get Status' button.
- Interface:** A box around the top-right 'Interface' dropdown menu, which is currently set to 'USB'.
- Printer Setup:** A large box around the main configuration area, including fields for Version, Serial No., Check Sum, and various printer settings like Speed, Density, Paper Width, Paper Height, Media Sensor, Gap, Post-Print Action, Cut Piece, Reference, Direction, Offset, Shift X, Shift Y, and various sensor/intensity settings.

1. Connect the printer and computer with a USB cable. The printer connects with the computer via USB to USB cable or USB to RS-232 cable (option).
2. Double click on the Configuration Utility icon  to start the software.
3. Select the printer interface connected with M4L printer.

USB to USB cable	USB to RS-232 cable
Interface <input type="text" value="USB"/> <input type="button" value="Setup"/> <p>The default interface setting is USB. If USB interface is connected with printer, no other settings need to be changed in the Interface field.</p>	Interface <input type="text" value="COM"/> <input type="button" value="Setup"/> <div style="border: 1px solid red; padding: 2px;"> <input type="text" value="USB"/> <input style="background-color: blue; color: white;" type="text" value="COM"/> <input type="text" value="LPT"/> <input type="text" value="ETHERNET"/> </div>

- Click the “Printer Function” button to setup. The detail functions in the Printer Function Group are listed below.

Printer Function	Function	Description
<input type="button" value="Calibrate Sensor"/>	Calibrate Sensor	Calibrate the sensor specified in the Printer Setup group media sensor field
<input type="button" value="RTC Setup"/>	RTC Setup	Synchronize printer Real Time Clock with PC
<input type="button" value="Factory Default"/>	Factory Default	Initialize the printer and restore the settings to factory default.
<input type="button" value="Reset Printer"/>	Reset Printer	Reboot printer
<input type="button" value="Print Test Page"/>	Print Test Page	Print a test page
<input type="button" value="Configuration Page"/>	Configuration Page	Print printer configuration
<input type="button" value="Dump Text"/>	Dump Text	To activate the printer dump mode.
<input type="button" value="Ignore AUTO.BAS"/>	Ignore AUTO.BAS	Ignore the downloaded AUTO.BAS program. This function will cause the printer to reboot.
<input type="button" value="Exit Line Mode"/>	Exit Line Mode	Exit line mode if the printer is in CPCL. This action allows the user to use Configuration Utility to setup the printer.
<input type="button" value="Password Setup"/>	Password Setup	Set the password to protect the settings
<input type="button" value="Active Emulation"/>	Active Emulation	Select ZPL or CPCL emulation

Performing a Calibrate Sensor by Configuration Utility

The Configuration Utility is a highly recommended way to Auto Calibrate the Gap and Black Mark sensors and for calculating a Paper Out threshold value for the printer. This function can be used instead of the Power-On Utility method described in Chapter 4. This procedure uses values entered in the **Sensor** menu on page 37 and the Calibrate Sensor menu page shown below.

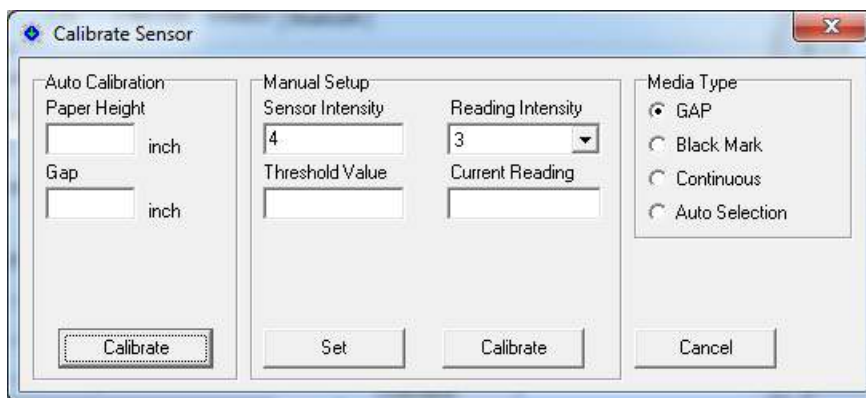

Calibrate Sensor – Auto Calibrate

Use the following steps to **Auto Calibrate** the Calibrate Sensor Printer Function:

- Load desired media in the printer and close the media cover.
- Within the **Sensor** menu on page 37:
- **Mandatory:** Enter the actual **Paper Height** and **Gap** (or Black Mark) height value in inches.
- **Mandatory:** Enter the correct **Media Sensor** type (GAP, Black Mark or Continuous).
- **Mandatory:** Verify that the **Maximum Length** value = 10.00 inch (Default) or 1.0 inch or greater than the height of the installed media. This value is the maximum distance the printer will advance media during an Auto Calibrate in search of a Gap or Black Mark.
- Verify **Threshold Detection** is set to **FIXED** (Default).
- Click the Calibrate Sensor - Printer Function to open the Calibrate Sensor menu page.
- Under **Auto Calibrate**, select **Calibrate**.

NOTE: It is not necessary to enter the **Paper Height** or **Gap/Mark** values in the Auto Calibrate menu prior to selecting Calibrate if **Threshold Detection = FIXED**. If **Threshold Detection = AUTO**, you must enter these values so that an accurate Paper Out value can be calculated.

When **Calibrate** is selected the printer will advance 2 to 3 labels for Gap or Black Mark Sensing and stop with the Gap or Black Mark positioned at the Tear Bar.

NOTE: No media will advance if Media Sensor type = Continuous.

Press the M4L Control Panel Feed key - the printer should advance one label and stop with the Gap or Mark at the Tear Bar.

IMPORTANT When a new media type is used for the first time, it is recommended that after an Auto Calibrate, you remove the media and close the media cover to verify that the printer will detect an actual paper out and display a “No Paper” fault message.

New Calibration values are automatically saved to the printer and will remain after cycling printer power.

Calibrate Sensor - Manual Setup

This method of calibrating the sensors is usually used only when the Auto Calibrate methods fail to reliably detect TOF (Top of Form) and/or calculate an actual Paper Out condition. This method is reserved for unusual media with holes or preprinted images that may trick the sensors in seeing them as a Black Mark or Gap affecting TOF.

1. Install desired media in the printer and close the media cover.
2. Select the **Media Type** (GAP, Black Mark Continuous or Auto Selection) located to the right of the Manual Setup.
3. Select **Calibrate**, an instruction prompt will appear under the Manual Setup.

Example: **Put liner please** (user must pull media out until liner gap is detected) then press **Next**.

Followed by: **Put label please** (user must pull media out until label is detected) then press **Next**.

Followed by: **Calibration is complete** or **Can't Calibrate**

If Calibration was complete, the following will display (example):

Label Reading 388

Gap Reading 950

Press the M4L Control Panel Feed key - the printer should advance one label and stop with the Gap or Mark at the Tear Bar.

IMPORTANT When a new media type is used for the first time, it is recommended that after a Manual Setup Calibrate, you remove the media and close the media cover to verify that the printer will detect an actual paper out and display a “No Paper” fault message.

New Calibration values are automatically saved to the printer and will remain after cycling printer power.

Configuration Utility ZPL2 Emulation Menu

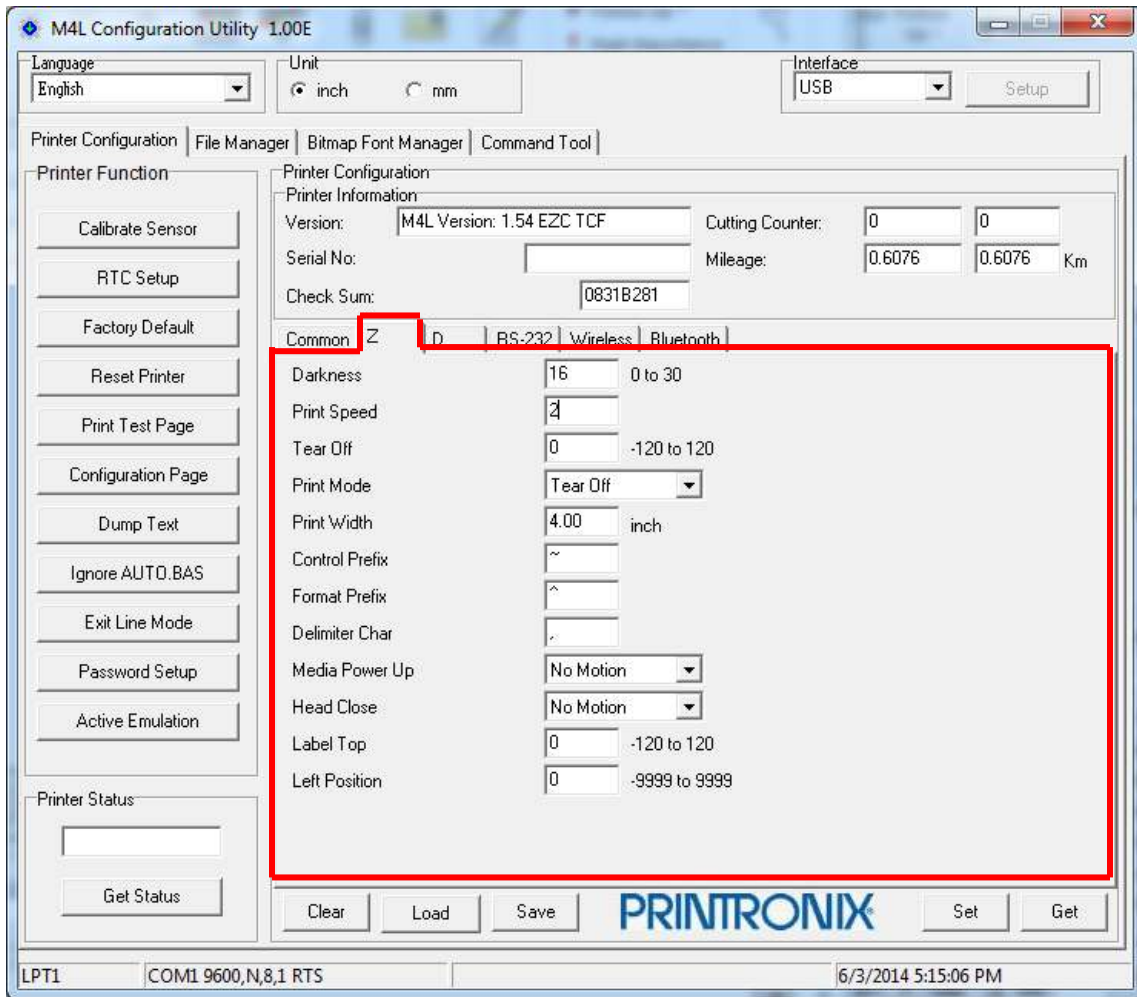

Darkness	Range = 0 to 30	Default = 16
Print Speed	Range = 1 to 4 ips	Default = 2 ips
Tear Off	Range = -120 to 120 dots	Default = 0
		- dot value, label TOF stops below Tear Bar. +dot value, label TOF stops above Tear Bar.
Print Mode	Tear Off or Peel Off	
Print Width	Range = 0.01 to 4.10 inch	Default = 4.00 inch
Media Pwr Up	No Motion, Length, Calibration or Feed	Default = No Motion
Head Close	No Motion, Length, Calibration or Feed	Default = No Motion
Label Top	Range = -120 to 120 dots	Default = 0 dots
Left Position	Range = -9999 to 9999 dots	Default = 0 dots

NOTE: ZPL2 emulation menu item settings may be affected by Common menu item settings.

Setting AUTO.BAS by Configuration Utility

- Create an AUTO.BAS file and load it to the printer using the Command Tool Tab. See example AUTO.BAS file below.
- Reboot the printer to activate the AUTO.BAS. AUTO.BAS file will be executed first.
- Now you can send the print jobs.
- Configuration Utility commands will also run through AUTO.BAS. If the AUTO.BAS does not 'END', most of Configuration Utility commands will not work except 'Ignore AUTO.BAS' and 'Reset Printer'.
- To use Configuration Utility, after AUTO.BAS is activated, the user needs to click "Ignore AUTO.BAS" tab to do any configuration Utility operation, i.e. 'Get' or 'Calibrate Sensor', etc.
- To remove AUTO.BAS,
 - ◆ First click "Ignore AUTO.BAS" tab which will trigger the printer to reboot.
 - ◆ After the printer powers up, go to 'File Manager' tab and click 'Get' under 'File Information' from 'FLASH'.
 - ◆ You should see 'AUTO.BAS' listed.
 - ◆ Go to 'Command Tool' tab, enter the text 'KILL F,"AUTO.BAS"' (double quote around AUTO.BAS is required) and click 'Send'. This will remove 'AUTO.BAS' file in the flash file system.
 - ◆ Reset the printer.

Example of AUTO.BAS for setting the paper width.

```
DOWNLOAD F,"AUTO.BAS"  
^XA  
^PW400  
^JUS  
^XZ  
EOP
```

CPCL Emulation

In CPCL emulation there are two modes, GRAPHICS MODE and LINE PRINT MODE. The printer is designed to do emulation auto switching between ZPL2 and CPCL GRAPHICS MODE, but cannot auto switch from CPCL LINE PRINT MODE to ZPL2 emulation.

For print jobs in CPCL GRAPHICS MODE, the users do not need to switch emulation. Print jobs using LINE PRINT MODE, they need to manually switch to CPCL before printing. It can be done by using Configuration Utility 'Active Emulation' or by selecting CPCL from the M4L front panel.

When the printer is running CPCL LINE PRINT emulation, you will have to either select 'Exit Line Mode' or manually switch over to ZPL2 emulation to perform configuration utility operation.

Setting Bluetooth by Configuration Utility

Connect the printer and computer with a USB cable.

NOTE: The printer connects with the computer via USB to USB cable or USB to RS-232 cable (option).

1. Turn the printer power on using the Power key .
2. Open Configuration Utility and set interface (default setting is USB).
3. Select “Wireless” tab and click on “Built-in wireless module” item.

USB to USB cable	USB to RS-232 cable
Interface <input type="text" value="USB"/> Setup	Interface <input type="text" value="COM"/> Setup
The default interface setting is USB interface. If USB interface is connected with printer, no other settings need to be changed in the interface field.	<input type="text" value="USB"/> <input type="text" value="COM"/> <input type="text" value="LPT"/> <input type="text" value="ETHERNET"/>

4. Enter the new BT Local Name or BT PIN Code in the editor.
5. Press “Set” button to set the new BT name or BT PIN code of the printer.
6. Press “Get” button to get back the settings. Make sure the Bluetooth module settings are set properly

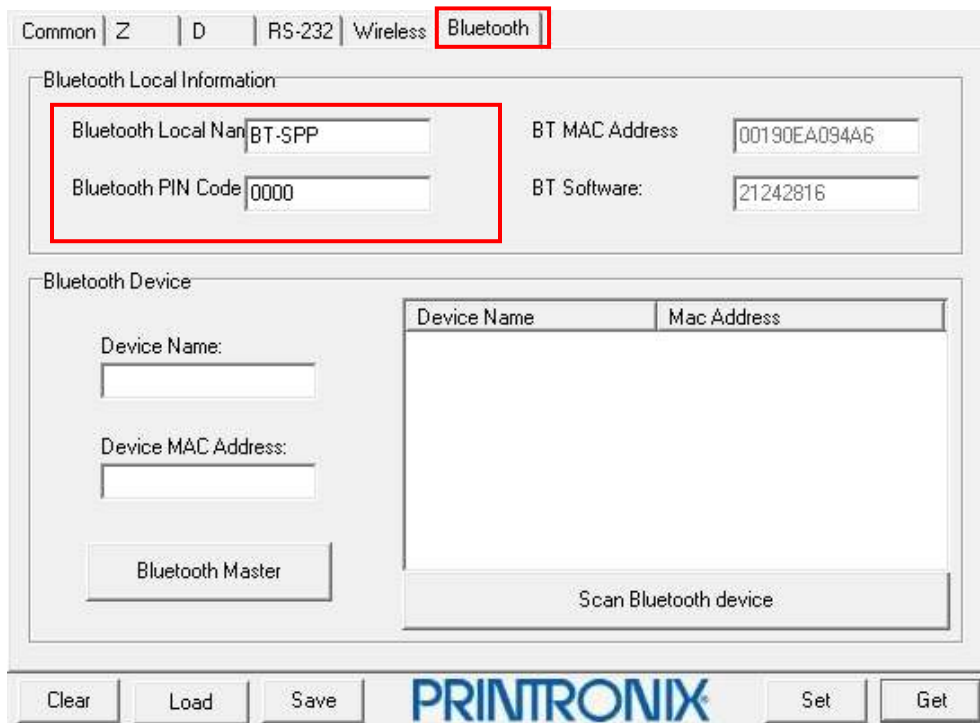

Setting WiFi by Configuration Utility

Connect the printer and computer with a USB cable.

Note: The printer connects with the computer via USB to USB cable or USB to RS-232 cable (option).

1. Turn the printer power on using the Power key .
2. Open Configuration Utility and set interface (default setting is USB).

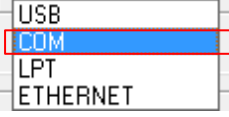
USB to USB cable	USB to RS-232 cable
Interface <input type="text" value="USB"/> <input type="button" value="Setup"/>	Interface <input type="text" value="COM"/> <input type="button" value="Setup"/>
The default interface setting is USB. If USB interface is connected with printer, no other settings need to be changed in the interface field.	

3. Select “Wireless” tab and click on “Built-in wireless module” item.
4. Enter the new WLAN settings in the editor.
5. Enter WLAN SSID matching with the AP.
6. Select WLAN Encryption matching with the AP.
7. Enter WLAN Key if WEP or WPA Personal
8. Press “Set” button to set the new settings to the printer.
9. The Wi-Fi icon will be shown in the LCD panel if the device has been connected.
10. Ping the device to confirm the connectivity.
11. Print out the self-test page to confirm if it’s connected with the correct settings.
12. Remove the cable to print data for testing
13. To clear all the wireless setting, press Wireless Factory Default button.

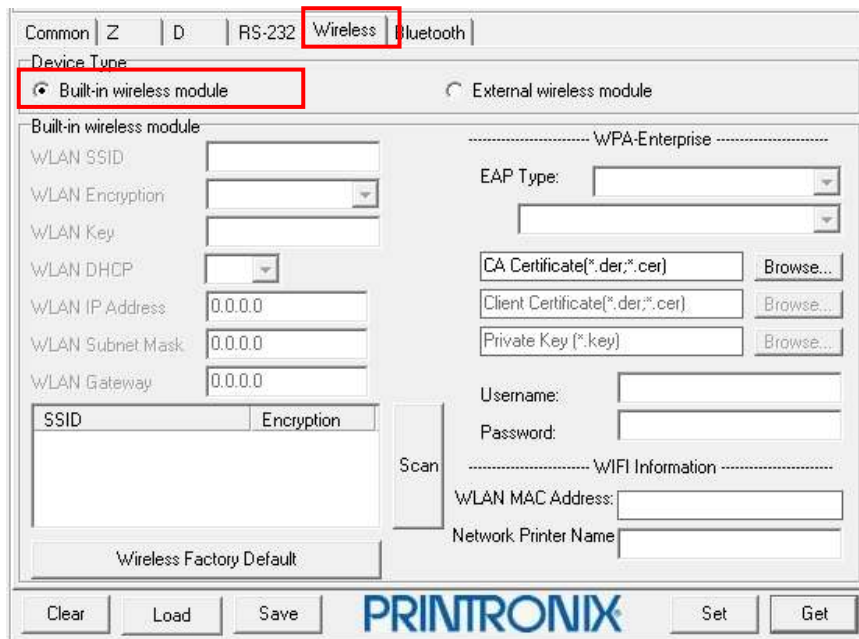

NOTE: WLAN Encryption does not represent the encryption used in the current connection. WLAN Encryption selection is used for setting up the WLAN WEP/WPA/WPA2 Parameters. The actual encryption is determined by the AP that the printer is associated with.

6 LCD Menu Function













The M4L has an LCD panel to further enhance its capabilities to meet the demands of a wide range of printing solutions. This includes an LCD control panel, 4 keys and 2 LED status indicators.

Using the LCD to Set the Printer

Press the “M” key to display the function menu screen as shown below





Use the 4 keys at the sides of the LCD to scroll, select, enter or return from the menu. The icon functions are listed below.

Icon	Function
	Display printer information Key
	Enter setting menu
	Power Key
	Scroll up
	Scroll down
	Return to previous menu
	Enter to next menu
	Enter setting mode
	Exit setting mode
	Save the selected settings and return to previous menu
	Select
	Alter to OFF
	Alter to ON

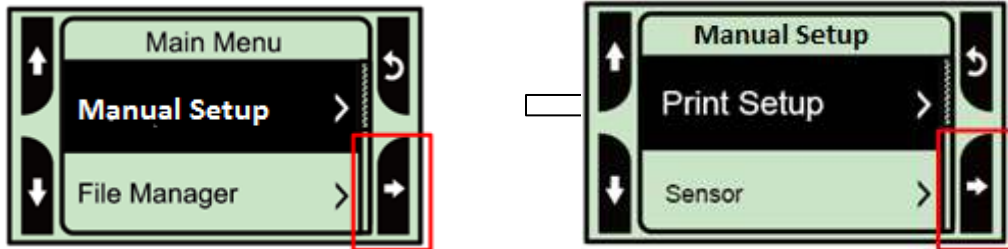

Example: To change the Speed setting, follow the steps below:

Press “M” key to enter the Main menu. Press the Feed key  to enter the “Manual Setup” item.

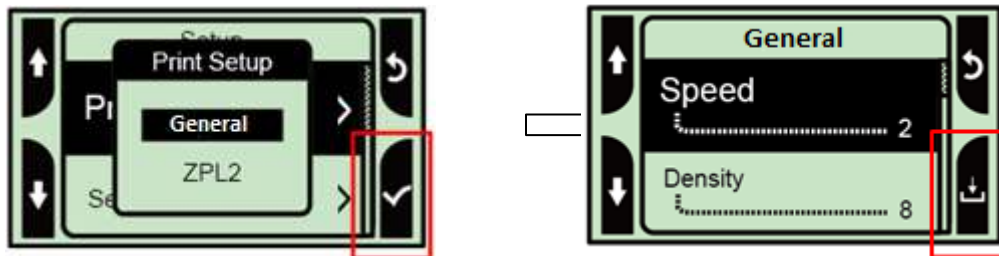

Press the Feed key  to enter the “Print Setup” item. Press the Feed key  to select the “General” item and display the “Speed” setting mode.



Press the Feed key  to enter to highlight the current speed setting. At this status, you can scroll up or scroll down to select the value of print speed. Then press the Feed key  to save the selected value into the printer. Press the Power key  multiple times to go back to “Ready mode”.

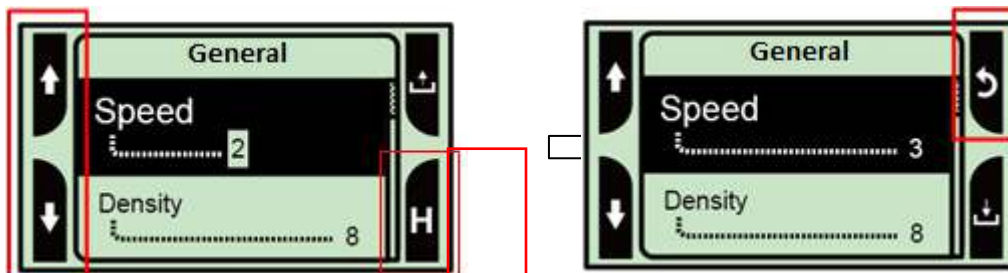

Menu Map

There are 6 categories for the main menu. You can easily set the settings of the printer without connecting it to a computer. Please refer to the following sections for more details.

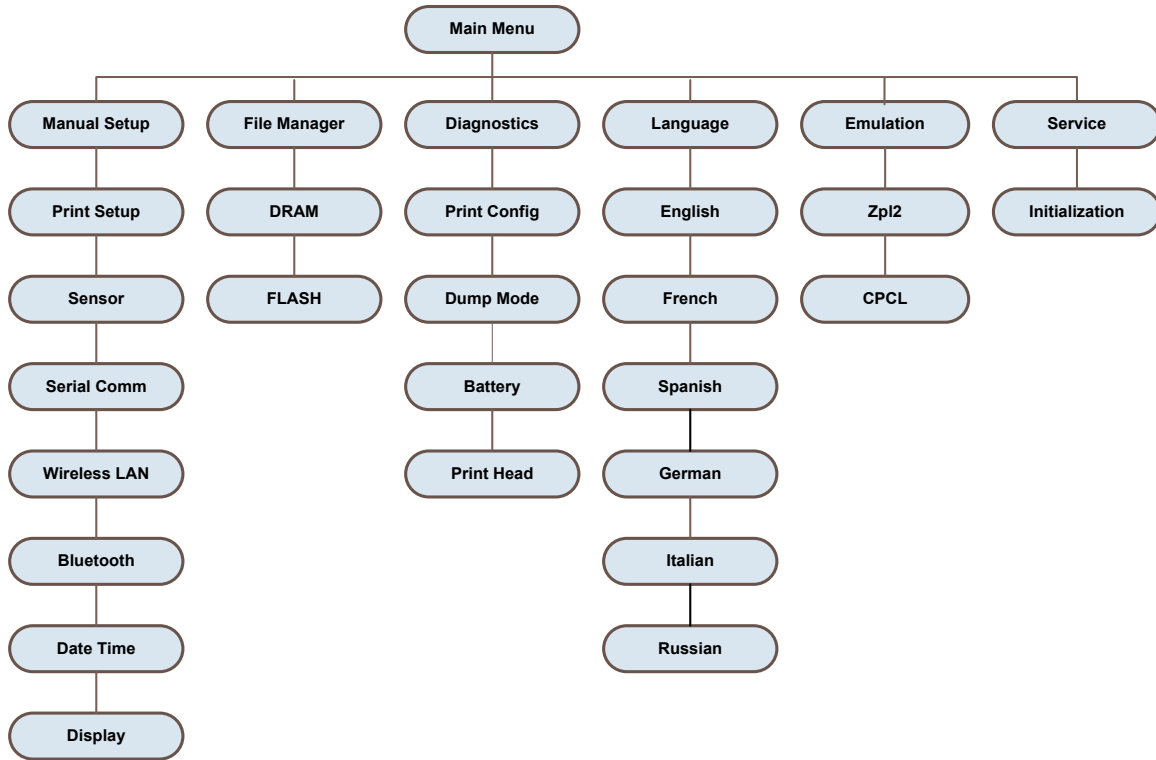

Print Setup for General

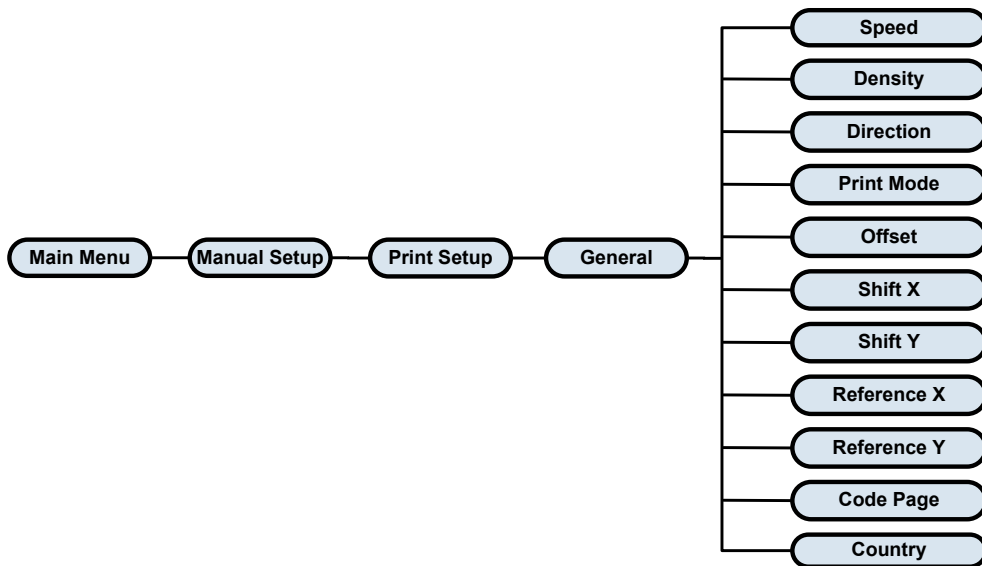

Print Setup for ZPL2

Item	Description	Default										
Darkness	Use this item to setup printing darkness. The available setting is from 0 to 30, and the step is 1. You may need to adjust your darkness based on selected media.	16										
Print Speed	Use this item to setup print speed. Available setting is from 1 to 4.	2										
Tear Off	This item is used to fine tune media stop location in dots. Available value is from -120 to +120 dots.	0										
Print Mode	<p>This item is used to set the print mode. There are 2 modes as below,</p> <table border="1"> <thead> <tr> <th>Print Mode</th> <th>Description</th> </tr> </thead> <tbody> <tr> <td>Tear Off</td> <td>Next label top of form is aligned to the print head burn line location</td> </tr> <tr> <td>Peel Off</td> <td>Enable the Label Peel Off mode</td> </tr> </tbody> </table>	Print Mode	Description	Tear Off	Next label top of form is aligned to the print head burn line location	Peel Off	Enable the Label Peel Off mode	Tear Off				
Print Mode	Description											
Tear Off	Next label top of form is aligned to the print head burn line location											
Peel Off	Enable the Label Peel Off mode											
Print Width	This item is used to set print width in dots. Available value is from "2" to "832 dots".	812										
List Fonts	This feature is used to print current printer available fonts list to the label. The fonts stored in the printer's DRAM, Flash or optional memory card.	N/A										
List Images	This feature is used to print current printer available images list to the label. The images stored in the printer's DRAM, Flash or optional memory card.	N/A										
List Formats	This feature is used to print current printer available formats list to the label. The formats stored in the printer's DRAM, Flash or optional memory card.	N/A										
List Setup	This feature is used to print current printer configuration to the label.	N/A										
Control Prefix	This feature is used to set control prefix character.	<~>										
Format Prefix	This feature is used to set format prefix character.	<^>										
Delimiter Char	This feature is used to set delimiter character.	<,>										
Media Power Up	<p>This option is used to set the action of the media when you turn on the printer.</p> <table border="1"> <thead> <tr> <th>Selections</th> <th>Description</th> </tr> </thead> <tbody> <tr> <td>Feed</td> <td>Printer will advance one label</td> </tr> <tr> <td>Calibration</td> <td>Printer will calibrate the sensor levels, determine length and feed label</td> </tr> <tr> <td>Length</td> <td>Printer will determine length and feed label</td> </tr> <tr> <td>No Motion</td> <td>Printer will not move media</td> </tr> </tbody> </table>	Selections	Description	Feed	Printer will advance one label	Calibration	Printer will calibrate the sensor levels, determine length and feed label	Length	Printer will determine length and feed label	No Motion	Printer will not move media	No Motion
Selections	Description											
Feed	Printer will advance one label											
Calibration	Printer will calibrate the sensor levels, determine length and feed label											
Length	Printer will determine length and feed label											
No Motion	Printer will not move media											
Head Close	<p>This option is used to set the action of the media when you close the printhead</p> <table border="1"> <thead> <tr> <th>Selections</th> <th>Description</th> </tr> </thead> <tbody> <tr> <td>Feed</td> <td>Printer will advance one label</td> </tr> <tr> <td>Calibration</td> <td>Printer will calibrate the sensor levels, determine length and feed label</td> </tr> <tr> <td>Length</td> <td>Printer will determine length and feed label</td> </tr> <tr> <td>No Motion</td> <td>Printer will not move media</td> </tr> </tbody> </table>	Selections	Description	Feed	Printer will advance one label	Calibration	Printer will calibrate the sensor levels, determine length and feed label	Length	Printer will determine length and feed label	No Motion	Printer will not move media	No Motion
Selections	Description											
Feed	Printer will advance one label											
Calibration	Printer will calibrate the sensor levels, determine length and feed label											
Length	Printer will determine length and feed label											
No Motion	Printer will not move media											
Label Top	This option is used to adjust print position vertically on the label. The range is -120 to +120 dots.	0										
Left Position	This option is used to adjust print position horizontally on the label. The range is -9999 to +9999 dots.	0										

Note: If printing from enclosed software/driver, the software/driver will send out the commands, which will overwrite the settings set from the LCD panel.

Sensor

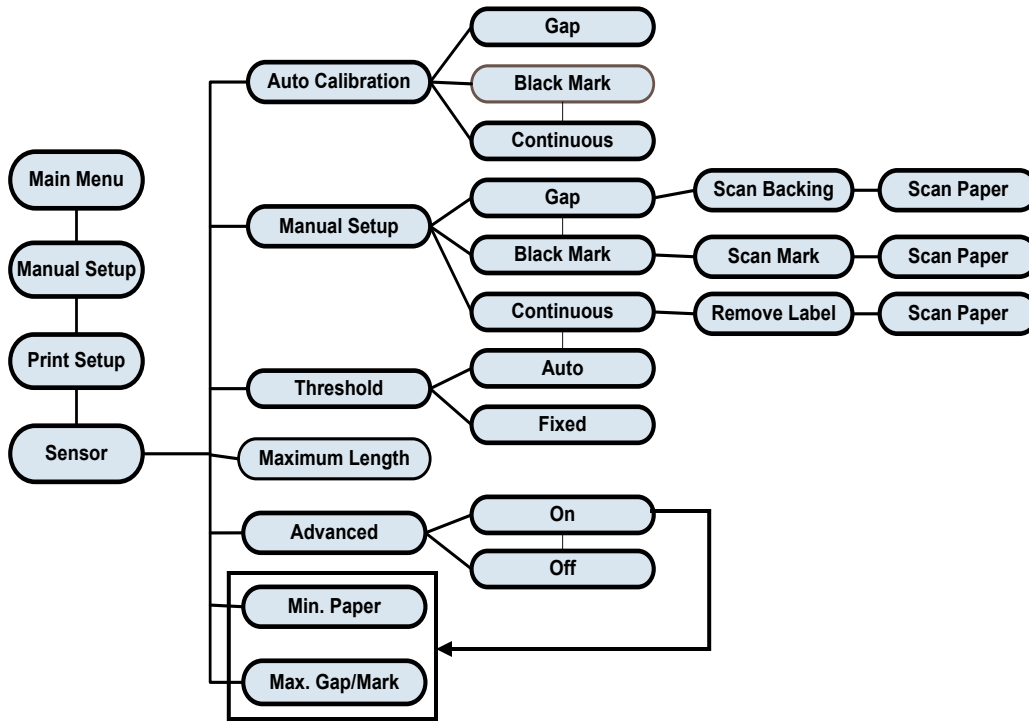

Item	Description	Default
Auto Calibration	This item is used to set the media sensor type and calibrate the selected sensor. Printer will feed 2 to 3 gap labels to calibrate the sensor sensitivity automatically.	N/A
Manual Setup	In case “Auto Calibration” cannot apply to the media, please use “Manual Setup” function to calibrate the sensor manually. Follow the LCD steps as shown. Note: You can open the media cover to move the paper but have to close the media cover for each scan.	N/A
Threshold	This item is used to fix the calibrated sensor sensitivity.	Fixed
Maximum Length	This item is used to set the max. Calibrate length.	253
Advanced	This item is used for pre-printed paper. If this advanced function is turned “ON” then you can setup the min. paper and max. gap/black mark size.	OFF

Serial Comm.

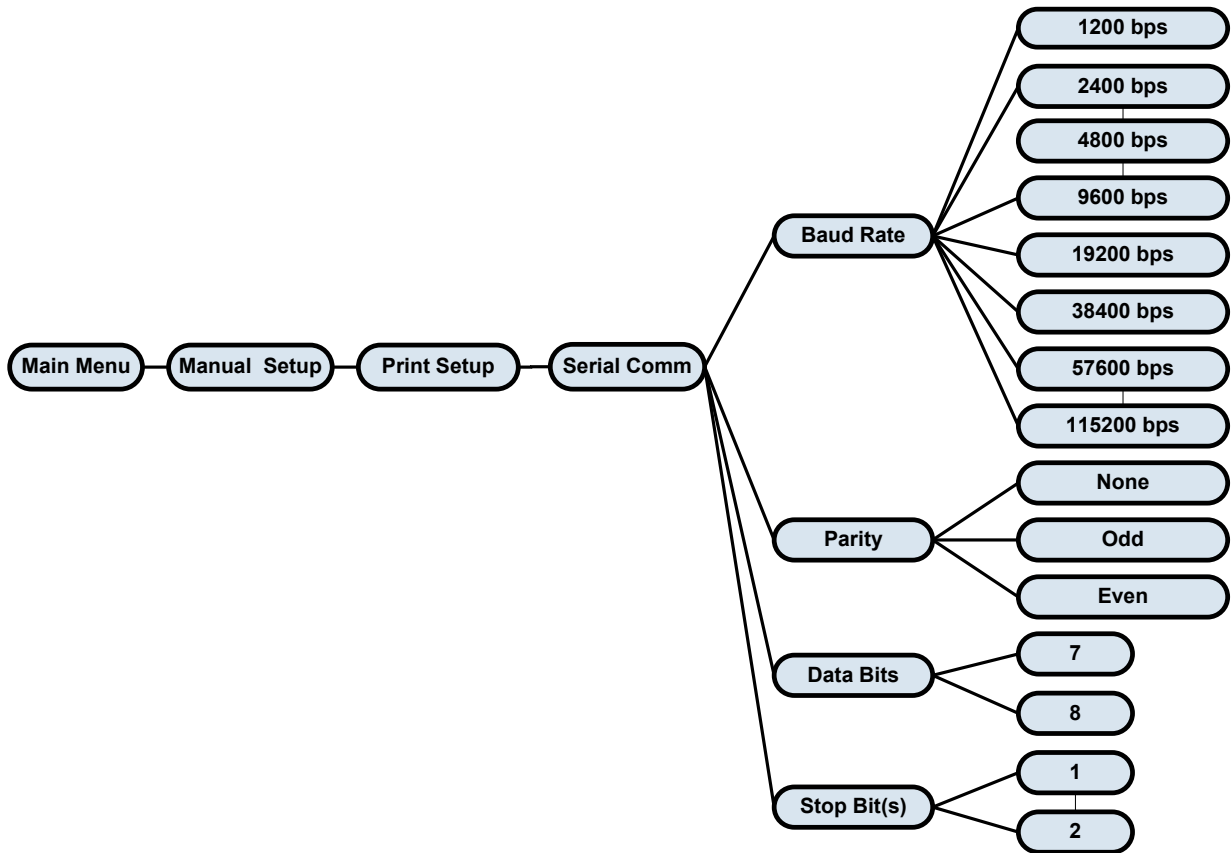

Item	Description	Default
Baud Rate	This item is used to set the RS-232 baud rate.	9600
Parity	This item is used to set the RS-232 parity.	None
Data Bits	This item is used to set the RS-232 Data Bits.	8
Stop Bit(s)	This item is used to set the RS-232 Stop Bits.	1

Wireless LAN

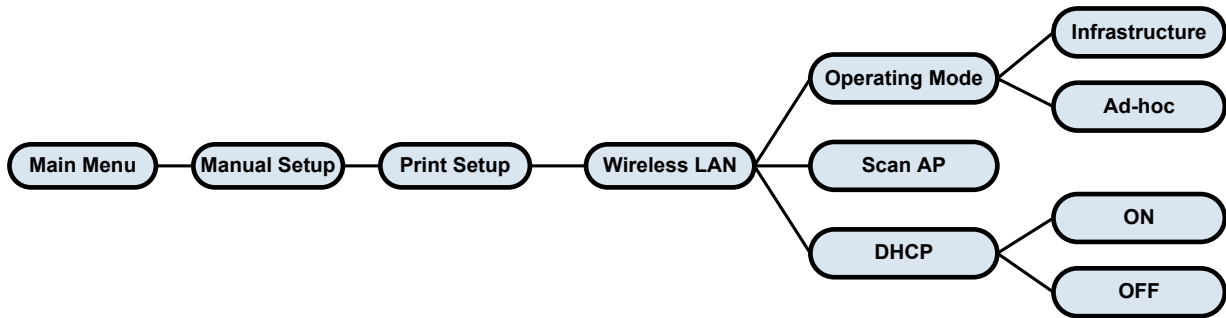

Item	Description	Default
Operating Mode	This item is used to set the operating mode of wireless local area networks to connect devices to the networks. Note: Infrastructure mode requires the use of an access point for this communication to take place. Ad hoc mode involves connecting a computer directly to another computer.	Infrastructure
Scan AP	This item is used to scan the access point device	N/A
DHCP	This item is used to ON (enable) or OFF (disable) the DHCP (Dynamic Host Configuration Protocol) network protocol.	ON

Bluetooth

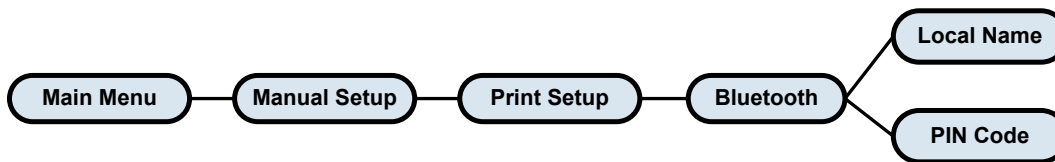

Item	Description	Default
Local Name	This item is used to set the local name for Bluetooth.	BT-SPP
PIN Code	This item is used to set the local PIN code for Bluetooth.	0

Date Time

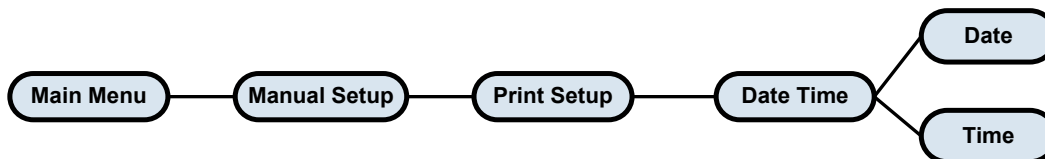

Item	Description	Default
Date	This item is used to set the date. (ex: 2013-05-30)	N/A
Time	This item is used to set the time. (ex: 19:20:02)	N/A

Display

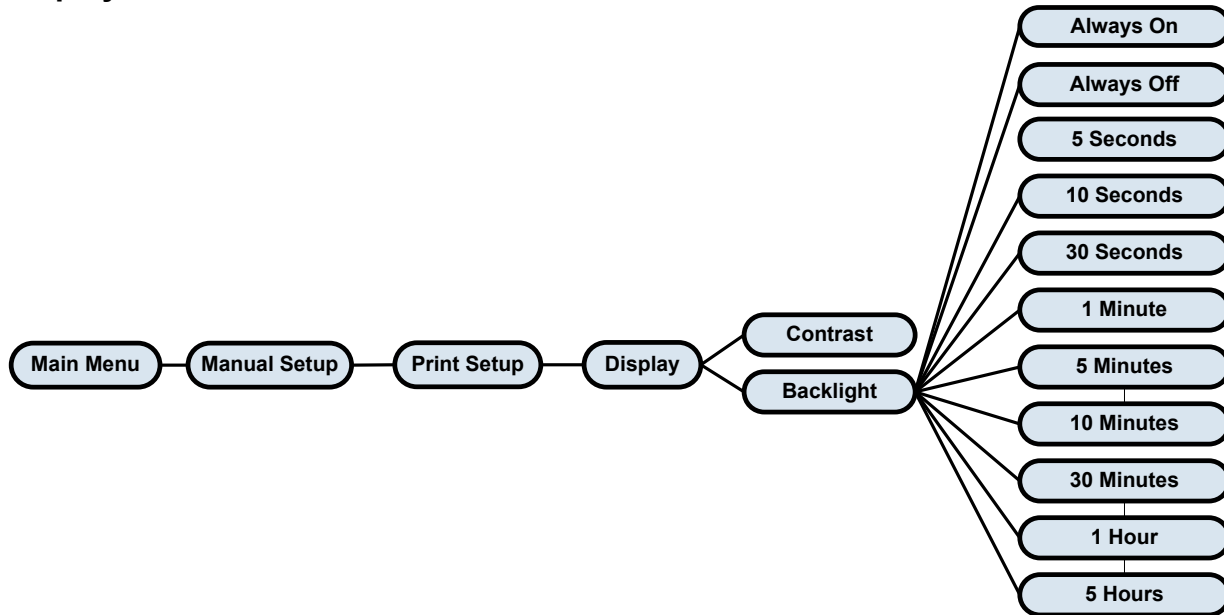

Item	Description	Default
Contrast	This item is used to set the contrast for the display.	50
Backlight	This item is used to set the backlight time for the display.	10 Seconds

File Manager

This feature is used to check the printer available memory and file list.

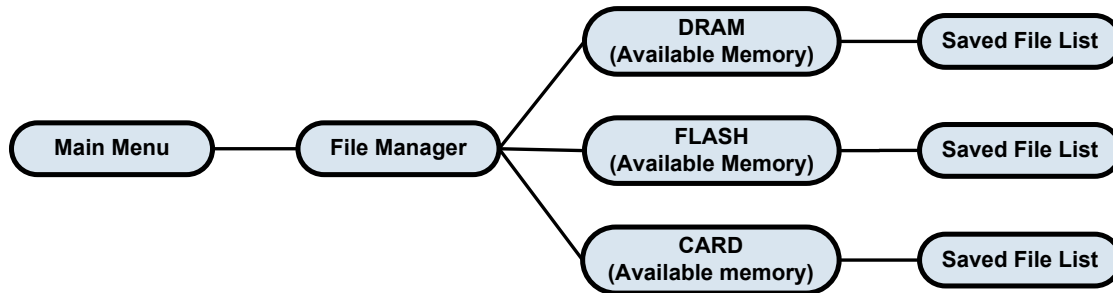

Item	Description
DRAM	Use this menu to show available memory space and run (.BAS) the files saved in the printer DRAM memory.
FLASH	Use this menu to show available memory space and run (.BAS) the files saved in the printer Flash memory.
CARD	Use this menu to show available memory space and run (.BAS) the files saved in the printer MicroSD card memory.

Diagnostics

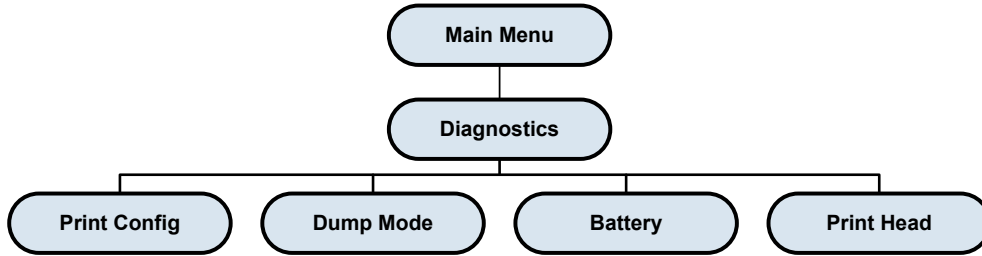

Print Config

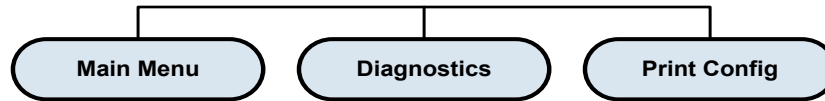

This feature is used to print current printer configuration to the label. On the configuration printout, there is a print head test pattern, which is useful for checking if there is any dot damage on the printhead heater elements. Please refer to the Section “Self Test” on page 23 for more details.

Dump Mode

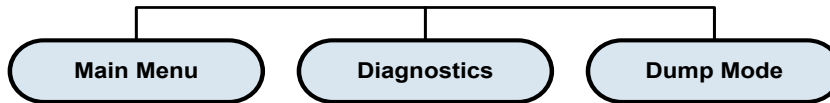

Captures the data from the communications port and prints out the data received by printer. In Dump mode, all characters will be printed in 2 columns. (Please refer to “Dump Mode” on page 25). The left side characters are received from your system and right side data are the corresponding hexadecimal value of the characters. It allows users or engineers to verify and debug the program.

NOTE: Dump mode requires 4” paper/label width.

Battery



This feature is used to check the printer battery voltage

Printhead

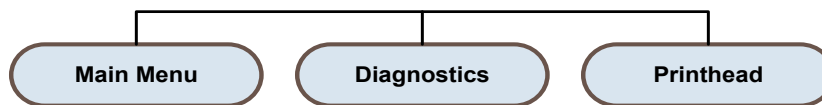

This feature is used to check the printer temperature, resistance and bad dots for the printhead.

Display Languages

This option is used to setup languages on LCD display

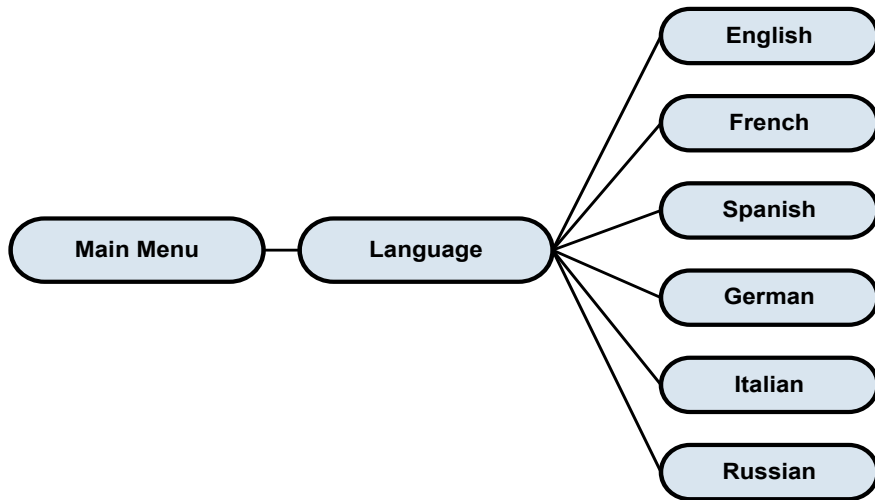

Emulation

This option is used to select the emulation

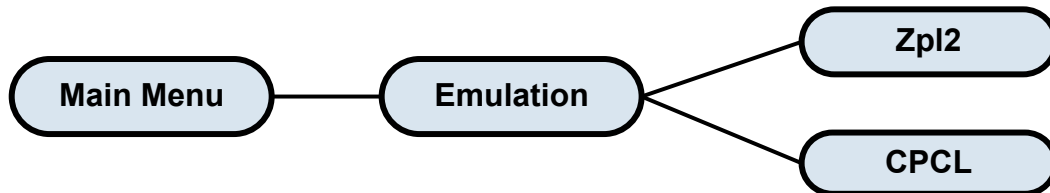

Service

This feature is used to restore printer settings to defaults. Please refer to “Printer Defaults” on page 25.

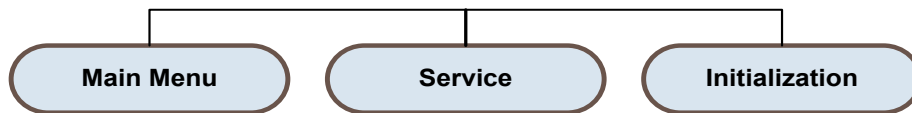

NOTE: When printer initialization is done, calibrate the gap or black mark sensor before printing or attempting any Self Tests.

7 *Trouble Shooting*

The following guide lists the most common problems that may be encountered when operating this bar code printer. If the printer still does not function after all suggested solutions have been invoked, please contact the Printronix Customer Support Center for assistance.

Problem	Possible Cause	Recovery Procedure
Power indicator does not illuminate	The battery is not properly installed. The battery is out of power. The battery is dead.	Reinstall the battery correctly. Power the printer on. Charge the battery. Replace with a new battery.
Not Printing	Check if interface cable is properly connected to the interface connector. Check if wireless or Bluetooth device settings match between the host and printer. The port specified in the Windows driver is not correct.	Reset the wireless device settings. Select the correct printer port in the driver.
No print on the label	Labels are not loaded correctly. Media may be installed wrong side out. The wrong type paper/labels are installed.	Follow the instructions in loading the media. Use direct thermal type paper/labels.
Printer status from the Configuration Utility or LCD shows "Cover Open".	The printer media cover is open or is not closed properly.	Close the media cover correctly.
Printer status from the Configuration Utility shows "Out of Paper" and LCD shows "No Paper"	The printer has run out of media. The media is installed incorrectly. Media sensor is not calibrated.	Install new media. Follow the instructions for loading roll or fanfold media. Calibrate the media sensor.
Printer status from the Configuration Utility or LCD shows "Paper Jam".	Media sensor is not set properly. Make sure media size is set properly. A label may be stuck inside the printer mechanism.	Calibrate the media sensor. Set media size correctly. Remove the stuck label from inside the printer mechanism.
Printer status from LCD shows "Strong light. Press FEED to print."	The Peel-off sensor can't work in strong lighted areas.	Move the printer to a proper place to print in peel-off mode.

Problem	Possible Cause	Recovery Procedure
Can't downloading the file to memory (FLASH / DRAM/CARD)	The selected memory space is full.	Delete unused files in the memory. The max. number of DRAM is 256 files. The max. user addressable memory space of DRAM is 2048KB. The max. number of FLASH files is 256 files. The max. user addressable memory space of FLASH is 14336KB.
Poor Print Quality	Media is loaded incorrectly Dust or adhesive accumulation on the printhead. Print density (darkness) is not set properly. Print speed is not set properly. Printhead element is damaged.	Reload media correctly. Clean the printhead. Clean the platen roller. Adjust the print density (darkness) and print speed. Run the printer self-test and check the printhead test pattern for dots missing in the pattern. Change to a proper media roll.
Missing printing on the left or right side of label	Too small of label width size is setup.	Set the correct label width size.
Gray line on the blank label	The printhead is dirty. The platen roller is dirty.	Clean the printhead. Clean the platen roller. Please refer to Maintenance Chapter.
Irregular printing	The printer is in Hex Dump mode. Dump mode is displayed on the LCD panel.	Turn the printer off and on to exit dump mode.
Media is not tracking properly. Printed images appear skewed or off center.	Roll media - Media holder hubs are not completely engaged into the media core. Roll media - Media holder hubs do not match the inner diameter of the media roll core in use.	Install media into the media holder hubs correctly. If 0.5 inch ID media roll cores are used, remove Phillips head screws that secure the 0.75/1.0 inch hubs to the media holders.
Media will not advance when print job is sent or when the Form Feed key is pressed.	Left side of media cover is not completely closed.	Verify left side of media cover is completely closed. NOTE: Cover open switch is located under right side of cover.
Tear Mode - Media does not tear properly against the tear bar.	Peel-Cover incorrectly placed in forward position and is interfering with Tear-Off.	Slide the Peel Cover toward the back of the printer when Tear mode is used.

Problem	Possible Cause	Recovery Procedure
<p>Printer does not detect a paper out "No Paper" fault condition when an actual paper out condition exists, causing a loss of printed labels after the end of the media roll.</p>	<p>Calibrate Sensor via Configuration Utility or Power-On Utility was never performed.</p> <p>Calibrate Sensor was performed, but Paper Height and Gap values were never entered when Threshold Detection was set to AUTO. Calibrate Sensor was performed, but Paper Height or Gap values entered did not match the installed media.</p> <p>Calibrate Sensor was performed, but the Maximum Length value entered was the same or less than the Paper Height value.</p> <p>Calibrate Sensor was performed, but the correct Media Type was not selected.</p> <p>Calibrate Sensor was performed, but a no paper (paper out) condition was not tested prior to running a print file.</p>	<p>NOTE: Unless a successful Calibrate Sensor is performed, the printer may be able to detect TOF but not able to detect an actual paper out (no paper) condition.</p> <p>In Configuration Utility, if Threshold Detection = AUTO, do a Calibrate Sensor (Auto Calibrate) making sure both Paper Height and Gap values are entered and match the actual height of the installed media and Mark or Gap height prior to enabling Calibrate.</p> <p>Make sure prior to enabling Calibrate that the Maximum Length value in the Common menu = 10.00 inch (default) or is set to a value 1.0 inch or greater than the actual Paper Height installed.</p> <p>Prior to doing a Calibrate Sensor, make sure the Media Type selected (GAP, Black Mark or Continuous) matches the media type installed.</p> <p>After doing an Auto Calibrate and before sending a print file, remove the media from the printer and close the media cover to verify the LCD shows a 'No Paper' fault.</p>

8 Maintenance

This section discusses how to maintain your printer.

1. Use one of following materials to clean the printer.
 - Cotton swab or authorized Printronix Thermal Printhead Cleaning Pen (203502-002)
 - Lint-free cloth
 - Vacuum / Blower brush
 - 100% Ethanol or 99.7% Isopropyl Alcohol
2. The cleaning process is as follows:

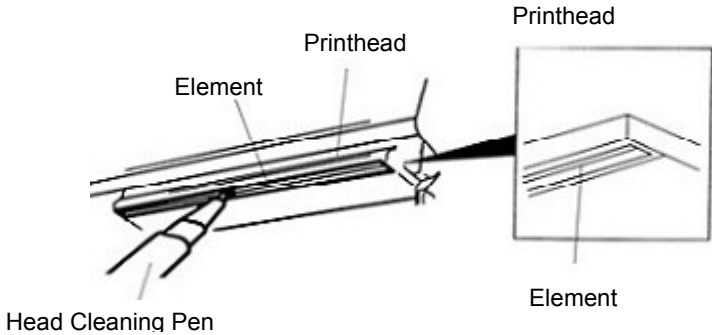
Printer	Method	Interval
PrintHead	<ol style="list-style-type: none"> 1. Always turn off the printer before cleaning the printhead. 2. Allow the printhead to cool for a minimum of one minute. 3. Use a cotton swab or thermal printhead cleaning pen and 100% Ethanol or 99.7% Isopropyl Alcohol to clean the printhead surface. 	Clean the printhead prior to installing a new label roll.
		
Platen Roller	<ol style="list-style-type: none"> 1. Turn the power off. 2. Rotate the platen roller and wipe it thoroughly with 100% ethanol alcohol or 99.7% isopropyl al a lint-free cloth. 	Clean the platen roller when changing a new label roll
Tear/Peel Bar	Use a lint-free cloth with 100% ethanol alcohol to wipe the Tear/Peel bar.	Clean as needed
Sensor	Use compressed air or vacuum	Clean monthly
Exterior	Wipe it with a damp cloth	Clean as needed
Interior	Brush or vacuum	Clean as needed

A *Contact Information*

Printronix Auto ID Customer Support Center

IMPORTANT Please have the following information available prior to calling the Printronix Auto ID Customer Support Center:

- Model number
- Serial number (located on the back of the printer)
- Installed options (i.e., interface and host type if applicable to the problem)
- Configuration printout: Refer to the *Administrator's Manual*.
- Is the problem with a new install or an existing printer?
- Description of the problem (be specific)
- Good and bad pictures that clearly show the problem (faxing or emailing of these pictures may be required)

Americas	(844) 307-7120 Service@PrintronixAutoID.com
Europe, Middle East, and Africa	+31 (0) 24 3030 340 EMEA_support@PrintronixAutoID.com
Asia Pacific	+886 3 990 6155 APAC_support@PrintronixAutoID.com
China	+86 755 2398 0479 CHINA_support@PrintronixAutoID.com



Corporate Offices

Printronix Auto ID

3040 Saturn Street, Suite
200, Brea, CA 92821
U.S.A.

Phone: (844) 307-7120

Fax: (657) 258-0817

Printronix Auto ID, EMEA Head Office

Georg-Wimmer-Ring 8b
D-85604 Zorneding, Germany

Phone: + 49 (0) 8106 37979-000

Email: EMEA_Sales@PrintronixAutoID.com

Printronix Auto ID, Asia Pacific Head Office

Taiwan
9F, No. 95, Minquan Rd.
Xindian Dist., New Taipei City
231 Taiwan (R.O.C)

Phone: +886 3 990 6155

Fax: +886 3 990 6215

Printronix Auto ID, China Head Office

Shenzhen
New World Center 2510 room
No. 6009, Yitian road
Futian District, Shenzhen
518000
China

Phone: +86 755 2398 0479

Fax: +86 755 2398 0773

Visit the Printronix web site at www.PrintronixAutoID.com

B Notices

This information was developed for products and services offered in the U.S.A.

Printronix Auto ID Technology, Inc. may not offer the products, services, or features discussed in this document in other countries. Consult your Printronix representative for information on the products and services currently available in your area. Any reference to a Printronix product, program, or service is not intended to state or imply that only that Printronix product, program, or service may be used. Any functionally equivalent product, program, or service that does not infringe any Printronix intellectual property rights may be used instead. However, it is the user's responsibility to evaluate and verify the operation of any non- Printronix product, program, or service.

Printronix may have patents or pending patent applications covering subject matter described in this document. The furnishing of this document does not give you any license to these patents. You can send license inquires, in writing, to:

Printronix Auto ID Technology, Inc.
3040 Saturn Street #200
Brea, CA 92821 U.S.A.

The following paragraph does not apply to the United Kingdom or any other country where such provisions are inconsistent with local law:

PRINTRONIX PROVIDES THIS PUBLICATION "AS IS" WITHOUT WARRANTY OF ANY KIND, EITHER EXPRESS OR IMPLIED, INCLUDING, BUT NOT LIMITED TO, THE IMPLIED WARRANTIES OF NON- INFRINGEMENT, MERCHANTABILITY OR FITNESS FOR A PARTICULAR

PURPOSE. Some states do not allow disclaimer of express or implied warranties in certain transactions, therefore, this statement may not apply to you.

This information could include technical inaccuracies or typographical errors. Changes are periodically made to the information herein; these changes will be incorporated in new editions of the publication. Printronix may make improvements and/or changes in the product(s) described in this publication at any time without notice.

Any references in this information to non-Printronix Web sites are provided for convenience only and do not in any manner serve as an endorsement of those Web sites. The materials at those Web sites are not part of the materials for this Printronix product and use of those Web sites is at your own risk.

Any performance data contained herein was determined in a controlled environment. Therefore, the results obtained in other operating environments may vary significantly. Some measurements may have been made on development-level systems and there is no guarantee that these measurements will be the same on generally available systems. Furthermore, some measurement may have been estimated through extrapolation. Actual results may vary. Users of this document should verify the applicable data for their specific environment.

Information concerning non-Printronix products was obtained from the suppliers of those products, their published announcements or other publicly available sources. Printronix has not tested those products and cannot confirm the accuracy of performance, compatibility or

any other claims related to non-Printronix products. Questions on the capabilities of non-Printronix products should be addressed to the suppliers of those products.

Note!

Before using this information and the product it supports, read the information and Communication Statements beginning on page 52.

If you are viewing this information softcopy, the photographs and color illustrations may not appear.

For online versions of this book, we authorize you to:

- Copy, modify, and print the documentation contained on the media, for use within your enterprise, provided you reproduce the copyright notice, all warning statements, and other required statements on each copy or partial copy.
- Transfer the original unaltered copy of the documentation when you transfer the related Printronix product (which may be either machines you own, or programs, if the program's license terms permit a transfer). You must, at the same time, destroy all other copies of the documentation.

You are responsible for payment of any taxes, including personal property taxes, resulting from this authorization.

Your failure to comply with the terms above terminates this authorization. Upon termination, you must destroy your machine readable documentation.

Communication Statements

Bluetooth Version

M4L-BT

WiFi(bgn) + Bluetooth Version

M4L-WG, M4L-W1, M4L-W2, MT4ea-WG, MT4ea-W1

WiFi(abgn) + Bluetooth Version

M4L-WW

WiFi(abgn) Version

M4L-WK, M4L-WA, M4L-WB, MT4ea-WK, MT4ea-WA

FEDERAL COMMUNICATIONS COMMISSION (FCC) STATEMENT

This equipment has been tested and found to comply with the limits for a Class B digital device, pursuant to part 15 of the FCC Rules. These limits are designed to provide reasonable protection against harmful interference in a residential installation. This equipment generates, uses and can radiate radio frequency energy and, if not installed and used in accordance with the instructions, may cause harmful interference to radio communications. However, there is no guarantee that interference will not occur in a particular installation. If this equipment does cause harmful interference to radio or television reception, which can be determined by turning the equipment off and on, the user is encouraged to try to correct the interference by one or more of the following measures:

Reorient or relocate the receiving antenna.

Increase the separation between the equipment and receiver.

Connect the equipment into an outlet on a circuit different from that to which the receiver is connected.

Consult the dealer or an experienced radio/ TV technician for help.

CAUTION:

Any changes or modifications not expressly approved by the grantee of this device could void the user's authority to operate the equipment.

This device complies with Part 15 of the FCC Rules. Operation is subject to the following two conditions:

This device may cause harmful interference, and

This device must accept any interference received, including interference that may cause undesired operation.

RF exposure warning (WiFi)

This equipment must be installed and operated in accordance with provided instructions and must not be co-located or operating in conjunction with any other antenna or transmitter. End-users and installers must be providing with antenna installation instructions and transmitter operating conditions for satisfying RF exposure compliance.

M4L-WG - SAR Value: 0.663 W/kg

M4L-WK - SAR Value: 0.89 W/kg

RF exposure warning (For M4L-WG Bluetooth enabled devices only)

The equipment complies with FCC RF exposure limits set forth for an uncontrolled environment. The equipment must not be co-located or operating in conjunction with any other antenna or transmitter.

Canada, Industry Canada (IC) Notices

This device complies with Canada licence-exempt RSS standard(s).

Operation is subject to the following two conditions: (1) this device may not cause interference, and (2) this device must accept any interference, including interference that may cause undesired operation of the device.

Canada, avis d'Industry Canada (IC)

Cet appareil est conforme avec Industrie Canada exemptes de licence RSS standard(s).

Son fonctionnement est soumis aux deux conditions suivantes : (1) cet appareil ne doit pas causer d'interférence et (2) cet appareil doit accepter toute interférence, notamment les interférences qui peuvent affecter son fonctionnement.

Radio Frequency (RF) Exposure Information

The radiated output power of the Wireless Device is below the Industry Canada (IC) radio frequency exposure limits. The Wireless Device should be used in such a manner such that the potential for human contact during normal operation is minimized.

This device has been evaluated for and shown compliant with the IC Specific Absorption Rate ("SAR") limits when operated in portable exposure conditions.

Informations concernant l'exposition aux fréquences radio (RF)

La puissance de sortie émise par l'appareil de sans fil est inférieure à la limite d'exposition aux fréquences radio d'Industry Canada (IC). Utilisez l'appareil de sans fil de façon à minimiser les contacts humains lors du fonctionnement normal.

Ce dispositif a été évalué pour et démontré conforme à la Taux IC d'absorption spécifique ("SAR") des limites lorsqu'il est utilisé dans des conditions d'exposition portatifs.

Battery Safety Warning:

DO NOT throw the battery in fire.

DO NOT short circuit the contacts.

DO NOT disassemble the battery.

DO NOT throw the battery in municipal waste. Contact your local waste agency for the correct disposal procedure

CAUTION: Danger of explosion if battery is incorrectly replaced. Replace only with the same or equivalent type recommended by the manufacturer. Dispose of used batteries according to the manufacturer's instructions

The symbol of the crossed out wheeled bin indicates that the battery should not be placed in municipal waste.

CE Notice (European Union)

Marking by the CE symbol indicates compliance to the EMC directive and Low Voltage Directive of the European Union. Such marking is indicative that this system meets the following technical standards:

- EN 55022 "Limits and Methods of Measurement of Radio Interference Characteristics of Information Technology Equipment."
- EN 55024 "Electromagnetic Immunity Requirements for Information Technology Equipment"
- EN 60950 "Safety of Information Technology Equipment"
- EN 300328, EN 301489 "Electromagnetic Compatibility and Radio spectrum Matters"

Konformitätserklärung:

FCC Klasse B entspricht EMVG Klasse B

Für alle in Deutschland vertriebenen EN 55022 Klasse B Geräte:

Zulassungsbescheinigung laut dem Deutschen Gesetz über die elektromagnetische Verträglichkeit von Geräten (EMVG) vom 18. September 1998 (bzw. der EMC EG Richtlinie 89/336):

Dieses Gerät ist berechtigt in Übereinstimmung mit dem Deutschen EMVG das EG-Konformitätszeichen - CE - zu führen. Verantwortlich für die Konformitätserklärung nach Paragraph 5 des EMVG ist die:

Printronix Deutschland GmbH

Goethering 56

D-63067 Offenbach

Deutschland

Informationen in Hinsicht EMVG Paragraph 4 Abs. (1) 4:

Das Gerät erfüllt die Schutzanforderungen nach EN 55024 und EN 55022 Klasse B.

EN 55022 Klasse B Geräte müssen mit folgendem Warnhinweis versehen werden: "Warnung: dies ist eine Einrichtung der Klasse B. Diese Einrichtung kann im Wohnbereich Funkstörungen verursachen. In diesem Fall kann vom Betreiber verlangt werden, angemessene Maßnahmen durchzuführen und dafür aufzukommen."

EN 55024 Hinweis:

Wird dieses Gerät in einer industriellen Umgebung betrieben (wie in EN 55024 festgelegt), dann kann es dabei eventuell gestört werden. In solch einem Fall ist der Abstand bzw. die Abschirmung zu der industriellen Störquelle zu vergrößern.

Anmerkung:

Um die Einhaltung des EMVG sicherzustellen sind die Geräte, wie in den Printronix Handbüchern angegeben, zu installieren und zu betreiben.

Konformitätsklassen:

CE: EN 55022/24, IEC 61000-3-3, IEC 61000-3-2, EN 300328, EN 301489

EN 60950-1 durchgeführt von TÜV SÜD

Wichtige Sicherheits-Hinweise

1. Bitte lesen Sie die Hinweis sorgfältig durch.
2. Heben Sie diese Anleitung für den späteren Gebrauch auf.
3. Vor jedem Reinigen ist das Gerät vom Stromnetz zu trennen. Verwenden Sie keine Flüssig- oder Aerosolreiniger. Am besten eignet sich ein angefeuchtetes Tuch zur Reinigung.
4. Die Netzspannungs-Steckdose soll nahe dem Gerät angebracht und leicht zugänglich sein.
5. Das Gerät ist vor Feuchtigkeit zu schützen.
6. Bei der Aufstellung des Gerätes ist auf sicheren Stand zu achten. Ein Kippen oder Fallen könnte Beschädigungen hervorrufen.
7. Beachten Sie beim Anschluss ans Stromnetz die Anschlusswerte.
8. Dieses Gerät kann bis zu einer Außentemperatur von maximal 40°C betrieben werden.

Batterie-Sicherheitshinweis:

Batterie nicht in offenes Feuer werfen.

Batterie nicht kurzschließen.

Batterie nicht zerlegen.

Batterie nicht über den Hausmüll entsorgen.

Auf fachgerechte Entsorgung achten (Kennzeichnung durch durchgestrichene Mülltonne).

Achtung!

Explosionsgefahr bei unsachgemäßem Austausch der Batterie. Ersatz nur durch Original- oder vom Hersteller empfohlenen Typ. Entsorgung gebrauchter Batterien nach Angaben des Herstellers durchführen.

Software License Agreement

Your printer contains, among other software, application software, but not limited to the Ethernut Operating System (the "Ethernut Software") as embedded software. The terms of this Agreement apply to the Ethernut Operating System, and all other embedded software supplied with the printer. You accept the terms of this Agreement by your initial use of your printer.

The **Ethernut** operating system is a free operating system and can be found at <http://www.ethernut.de>. From its website: "This is an Open Source Hardware and Software Project for building tiny Embedded Ethernet Devices. The target software is an Open Source implementation of a Real Time Operating System called Nut/OS and a TCP/IP protocol suite named Nut/Net."

Ethernut is available under the BSD License (<http://www.opensource.org/licenses/bsd-license.php>). This license is very liberal and does not require any disclosure of proprietary application code or updates to the Ethernut code. The copyright included with the Ethernut source code is as follows:

```
/*
 * Copyright (C) 2004 by egnite Software GmbH. All rights reserved.
 *
 * Redistribution and use in source and binary forms, with or without
 * modification, are permitted provided that the following conditions
 * are met:
 *
 * 1. Redistributions of source code must retain the above copyright
 * notice, this list of conditions and the following disclaimer.
 * 2. Redistributions in binary form must reproduce the above copyright
 * notice, this list of conditions and the following disclaimer in the
 * documentation and/or other materials provided with the distribution.
 * 3. Neither the name of the copyright holders nor the names of
 * contributors may be used to endorse or promote products derived
 * from this software without specific prior written permission.
 *
 * THIS SOFTWARE IS PROVIDED BY EGNITE SOFTWARE GMBH AND CONTRIBUTORS
 * ``AS IS'' AND ANY EXPRESS OR IMPLIED WARRANTIES, INCLUDING, BUT NOT
 * LIMITED TO, THE IMPLIED WARRANTIES OF MERCHANTABILITY AND FITNESS
 * FOR A PARTICULAR PURPOSE ARE DISCLAIMED. IN NO EVENT SHALL EGNITE
 * SOFTWARE GMBH OR CONTRIBUTORS BE LIABLE FOR ANY DIRECT, INDIRECT,
 * INCIDENTAL, SPECIAL, EXEMPLARY, OR CONSEQUENTIAL DAMAGES (INCLUDING,
 * BUT NOT LIMITED TO, PROCUREMENT OF SUBSTITUTE GOODS OR SERVICES; LOSS
 * OF USE, DATA, OR PROFITS; OR BUSINESS INTERRUPTION) HOWEVER CAUSED
 * AND ON ANY THEORY OF LIABILITY, WHETHER IN CONTRACT, STRICT LIABILITY,
 * OR TORT (INCLUDING NEGLIGENCE OR OTHERWISE) ARISING IN ANY WAY OUT OF
 * THE USE OF THIS SOFTWARE, EVEN IF ADVISED OF THE POSSIBILITY OF
 * SUCH DAMAGE.
 *
 * For additional information see http://www.ethernut.de/
 *
 * Copyright (c) 1990 The Regents of the University of California.
 * All rights reserved.
 *
 * Redistribution and use in source and binary forms, with or without
 * modification, are permitted provided that the following conditions
 * are met:
 * 1. Redistributions of source code must retain the above copyright
 * notice, this list of conditions and the following disclaimer.
 * 2. Redistributions in binary form must reproduce the above copyright
```

* notice, this list of conditions and the following disclaimer in the
* documentation and/or other materials provided with the distribution.
* 3. Neither the name of the University nor the names of its contributors
* may be used to endorse or promote products derived from this software
* without specific prior written permission.

* THIS SOFTWARE IS PROVIDED BY THE REGENTS AND CONTRIBUTORS ``AS IS'' AND
* ANY EXPRESS OR IMPLIED WARRANTIES, INCLUDING, BUT NOT LIMITED TO, THE
* IMPLIED WARRANTIES OF MERCHANTABILITY AND FITNESS FOR A PARTICULAR PURPOSE
* ARE DISCLAIMED. IN NO EVENT SHALL THE REGENTS OR CONTRIBUTORS BE LIABLE
* FOR ANY DIRECT, INDIRECT, INCIDENTAL, SPECIAL, EXEMPLARY, OR CONSEQUENTIAL
* DAMAGES (INCLUDING, BUT NOT LIMITED TO, PROCUREMENT OF SUBSTITUTE GOODS
* OR SERVICES; LOSS OF USE, DATA, OR PROFITS; OR BUSINESS INTERRUPTION)
* HOWEVER CAUSED AND ON ANY THEORY OF LIABILITY, WHETHER IN CONTRACT, STRICT
* LIABILITY, OR TORT (INCLUDING NEGLIGENCE OR OTHERWISE) ARISING IN ANY WAY
* OUT OF THE USE OF THIS SOFTWARE, EVEN IF ADVISED OF THE POSSIBILITY OF
* SUCH DAMAGE.