

SOLID 33E-2

SOLID 58E

Operator's Manual

Edition 2.1M



Table of Contents

Chapter	Page
1. Introduction	7
1.1. General Description	7
1.2. Conventions	9
1.3. CE Conformity	10
1.4. General Safety Information	10
2. Installation	13
2.1. Check List	13
2.2. Printer Components	15
2.3. Environment and Power Standards	17
2.4. Printer Installation Instructions	20
2.4.1. Opening the Printer	20
2.4.2. Loading the Developer Unit	21
2.4.3. Activating the Toner Cartridge	24
2.4.4. Inserting the Waste Toner Bottle	27
2.4.5. Inserting the Cleaner Felt	29
2.4.6. Inserting the Ozone Filter	30
2.4.7. Installing the PC Cartridge (OPC)	31
3. Basic Operation Sequences	33
3.1. Overview	33
4. Handling of Consumables	35
4.1. Feeding of Continuous Materials	35
4.1.1. Handling of the Tractor Cassettes	35
4.1.2. Continuous Material Inserting	37
4.1.3. Material Supply Changing	42
4.2. Printed Material Output	43
4.2.1. Paper Stacker Selecting	43
4.2.2. Cutter Using	43
4.2.3. Operating the Automatic Paper Stacker System	45
4.2.3.1. Adjusting the Paper Stacker to the Page Length	45
4.2.3.2. Taking Printed Material from the Paper Stacker System	46

Chapter	Page
5. Operation and Menu Structure	47
5.1. Attaching the Printer to a Computer	47
5.2. Turning on the Printer	47
5.3. Control Panel View	49
5.4. Function of the Control Panel Elements	50
5.5. Configuration via the Control Panel	51
5.6. Menu Structure	53
5.7. Syntax of Diagrams	57
6. Panel Functions	59
6.1. Printing the Status Sheet	59
6.2. Printing the Font List	61
6.3. Hexdump Mode Activation	62
6.4. Normal Print Mode Activation (incl. FORM FEED)	63
6.5. Clearing the Input Buffer (Cancel Job)	64
6.6. Printing the Menu Page	65
6.7. Generating Testsheets (Sliding Pattern)	66
6.8. Tractor Cassette Selection (Feeder Select)	67
6.9. Stacker Selection	68
6.10. Page Length Adjusting	69
6.11. Selecting the Number of Printpages per Page Format (Two-Up Mode)	70
6.12. Paper Width Adjusting (Format Width)	72
6.13. Print Direction Selection	73
6.14. Data Interface Configuration	74
6.15. Emulation Selection	75
6.16. Display Language Selection	77
6.17. Transparent Code Adjustment	78
6.18. Selection of Memory Distribution (Input Buffer)	79
6.19. Setting to Factory Default	80
6.20. Font Selection	81
6.21. Text Orientation Selection	84
6.22. Symbol Code Selection	85
6.23. Configuration of Text Margins	86
6.24. Image Shifting to the X-Direction	87

Chapter	Page
6.25. Image Shifting to the Y-Direction	89
6.26. Adjusting the Cutting Position	91
6.27. Cutting Mode Selection	93
6.28. Standby Time Adjustment	95
6.29. Power Save Time Adjustment	96
6.30. Density Setting	97
6.31. Configuration of Network Parameters (IP Address e.g.)	98
7. Operator Maintenance	101
7.1. Printer Cleaning	101
7.1.1. Cleaning the Printer Cabinet	102
7.1.2. Cleaning the Printer Interior	103
7.2. Replacing the Toner Cartridge	108
7.3. Exchanging the Waste Toner Bottle	113
7.4. Replacing the Cleaner Felt	116
7.5. Exchanging the Ozone Filter	120
8. Troubleshooting	121
8.1. Error during the Print Process	122
8.2. Reduced Print Quality	123
8.3. Error Messages	124
8.4. Paper Jams	132
8.4.1. Possible Paper Jam Areas	133
8.4.2. Clearing Paper Jams	134
8.4.3. Paper Jam at the Tractor	135
8.4.4. How to open the Printer Covers	136
8.5. Print Repetition after an Error	138
9. Measures for Transport and Shipping (Repacking)	139
10. Specifications	141
11. Index	145

1. Introduction

1.1. General Description

The SOLID 33E-2 is a 33 pages per minute continuous-form printer (while employing A4 (8 1/3 inches) landscape format).

The SOLID 58E printer speed is up to 58 ppm (A4 Two-Up).

The printing resolution of both printers is 300 dots per inch corresponding to about 24 dots per mm.

The printers SOLID 33E-2 and SOLID 58E process paper types with a weight ranging from 64 to 156 g/m². The material to be printed on has to be provided with sprocket holes for the tractor to guide it. The SOLID 33E-2 processes continuous paper with a width of 4 up to 17 inches (16 inches printable). The paper width range of the SOLID 58E is 6 up to 18 inches (17 inches printable).

Both printers have two independent and detachable tractor cassettes. The automatic paper stacker system (optional) makes feeding and stacking of the continuous paper easy.

The cutter integrated inside the printers can be used for separating the print jobs and for cutting continuous paper into single sheets.

The MICROPLEX printer controller's high functionality with the SOLID 33E-2 and the SOLID 58E makes form printing simple. All kinds of information – e.g. bar codes, alphanumerical characters and vector graphics – can be printed.

The MICROPLEX printers are capable of using most of the page description languages used in the industrial field and also the business standards known in connection with laser printers can be used.

The capabilities featured include the MICROPLEX page description language IDOL. Using this language, complex tasks such as the creation of forms can be carried out by simple software commands (see separate IDOL manual).

Data can be sent from almost any software platform, because printer drivers are already available for this.

For the printer SOLID 33E-2 and SOLID 58E a software (called [IP_printADMIN](#)) will be available to allow a printer configuration via Ethernet. The controller has its integrated website with information on the printer status and the printjob status.

Consequently there is a multitude of scopes for this print systems. They are suitable for high-speed printing with excellent print quality using different types of materials.

Printing Basics

The MICROPLEX printer controller enables the connection of this print system to EDP systems whereby several interfaces, emulations and fonts are available.

The digital information (e.g. a text file) is transferred from the computer into the printer memory. The printer's electronic component (the controller) combined with the page description language, defines the letters, numbers, graphics, etc. into bit patterns and posts them into the controller's frame store.

In this way, a "pattern" of the future print page (generated by dots) is created.

The electronically controlled LED array plots the dot pattern in rows onto a rotating light-sensitive negatively charged drum.

At those drum spots impacted by the light the electronic charge is extinguished. The negatively charged toner will stick to these spots. Because similar charges repulse each other, the remaining drum surface stays blank. The paper is guided past the drum and the electrostatically charged toner particles are attracted by the paper. This process is supported by a positively charged field below the paper (transfer charger).

When transported further, the toner particles, which are affected by heat and pressure, are combined resistantly with the paper inside the fusing unit. The drum is discharged and cleaned.

1.2. Conventions

The following conventions should help you to find information and to understand instructions more easily:



This symbol refers to a possible source of danger. If you do not pay attention to this information, injuries may result, the function of the printer could be reduced or objects could be damaged.



This symbol refers to important hints and suggestions on using the printer. Disregarding these hints might cause problems with the printer or within the environments.

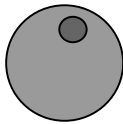

These symbols show two keys of the control panel. Such symbols will be used in this manual whenever keys have to be pressed in order to activate certain functions.

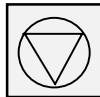

[blue colored text](#)

Link to another chapter or a different document. By clicking the blue colored text you'll enter the concerning chapter or document.

[Menu Level 1]

This symbol represents messages shown in the display (panel).

1.3. CE Conformity

The manufacturer hereby declares that the equipment complies with the guideline RL 89/336/EWG for information technology devices.

The determinations of the product standard concerning high frequency interferences of information technology devices EN 55022, class A/DIN VDE 0878 (electromagnetic interference) are complied.

Also the generic standard EN 50082-1/DIN VDE 0839 for interference strength is complied.

1.4. General Safety Information



This device produces, employs and possibly radiates high frequency energy. Because of this, incorrect installation can disturb radio communications.

This MICROPLEX product and its consumables are designed and tested according to strict safety standards.

Heeding the following instructions ensures secure operation:



- Please make sure your electricity source is properly grounded.
- Install the device on a solid and level place.
- Only trained staff are authorized to transport the equipment.



- Only use consumables which are specially developed for this device.

- Using improper consumables may cause a reduction of output quality or damage to the device.

- Ensure no liquids get on or into the device.

- Do not remove any cover or safety device fastened by screws.



- Do not bridge a safety device.

- Do not push anything into the ventilation apertures.

- Never perform installations, cleanings or maintenance work that is not described in this manual. Such work should only be done by MICROPLEX authorized service personnel.

In order to disconnect the printer quickly from the main power in the event of an emergency, please note the following:



- For printers connected by a plug, the power-outlet should be installed near the printer and easily within reach.

- For permanently connected printers, an easily accessible emergency power-off switch should be installed close to the printer.

- Please do not conceal any disconnect devices with the printer or other objects.



- Please follow all the instructions and hints directly attached to the device and/or described in this manual.

2. Installation

2.1. Check List

Please make sure that all items are included and that there are no defects. Immediately inform your supplier of any damage.

Open the cardboard box carefully and check the contents:

1. MICROPLEX SOLID 33E-2 or SOLID 58E printer
2. Starter Kit package
 - Developer Unit incl. Toner Cartridge
 - 2 Tractor Cassettes
 - PC Cartridge (OPC)
 - Cleaner Felt (for the fuser unit)
 - Ozone Filter
 - Toner Cartridge
 - AC power cord
 - Waste Toner Bottle
3. Automatic Paper Stacker System (optional)
4. CD containing:
 - Operator's Manual SOLID 33E-2, SOLID 58E
 - Print drivers
 - IDOL Programming Manual



The printer's first installation has to be done by a trained service engineer.



Please retain the original packing materials in case the printer has to be transported in the future. Use the original packing materials and adhesive fasteners to avoid damage to the internal components.

(See chapter 9 Measures for Transport and Shipping (Repacking)).

2.2. Printer Components

Main view:



Fig. 2.2.a Main view of the SOLID 33E-2 / 58E print systems

Rear view:



Fig. 2.2.b Printer's rear view: power supply

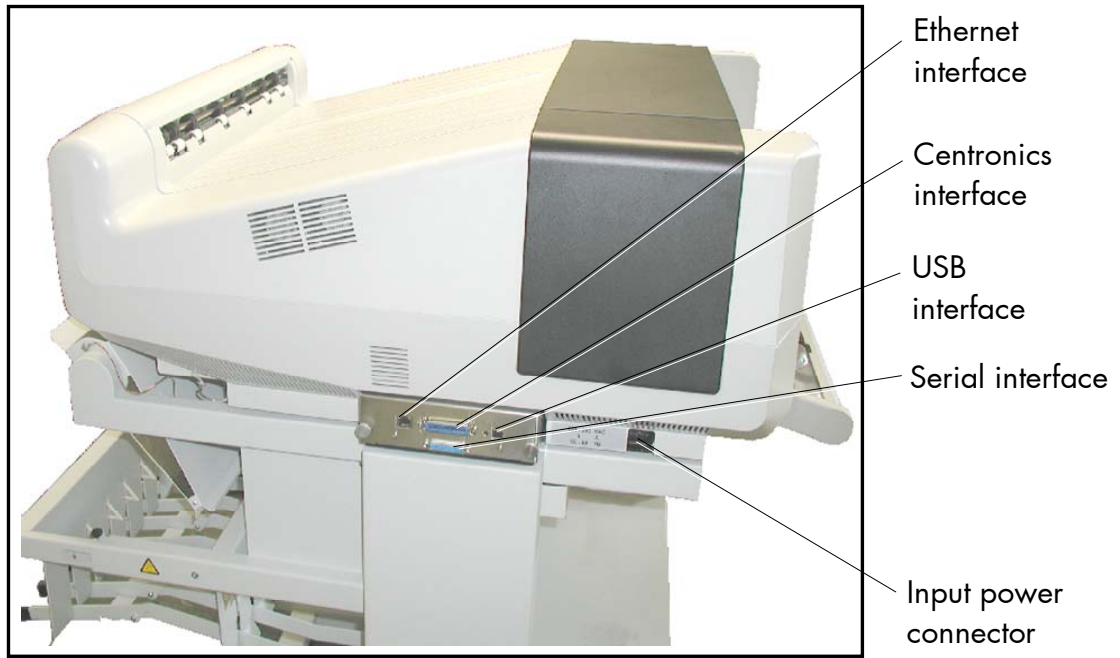

Fig. 2.2.c Printer's rear view: Interfaces

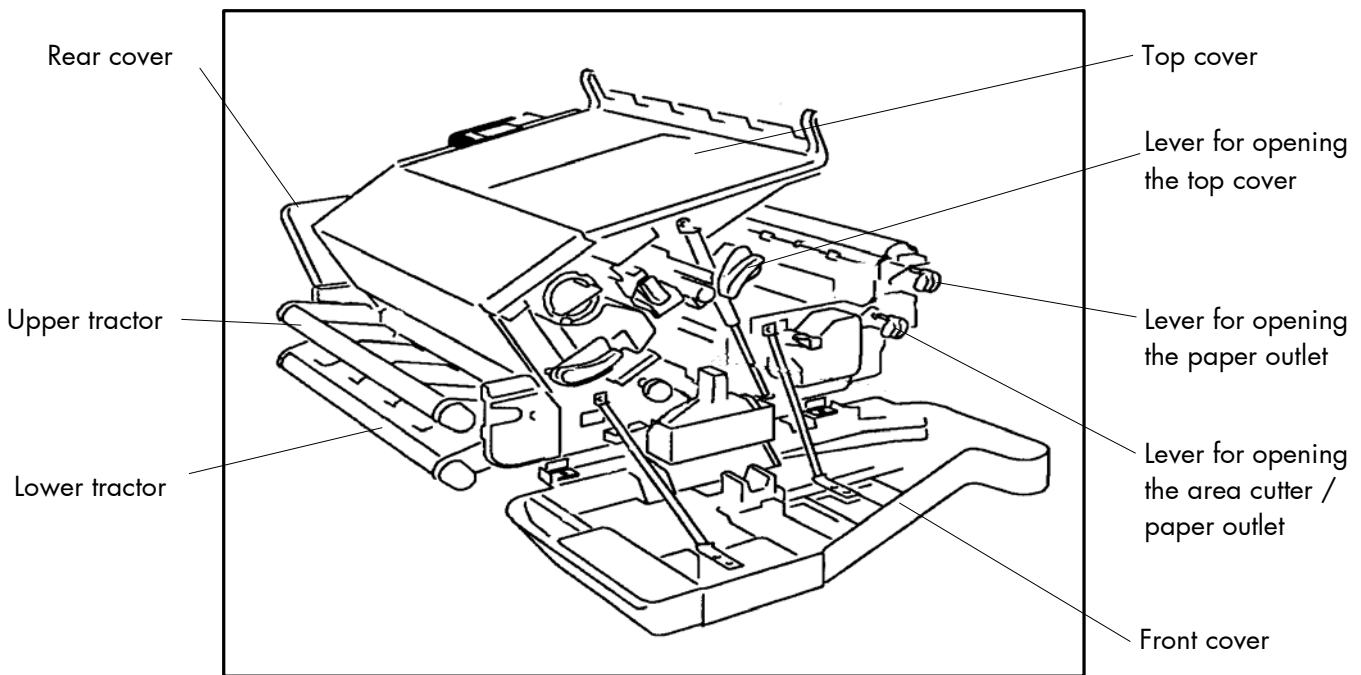

Fig. 2.2.d Printer SOLID 33E-2 / 58E opened

2.3. Environment and Power Standards

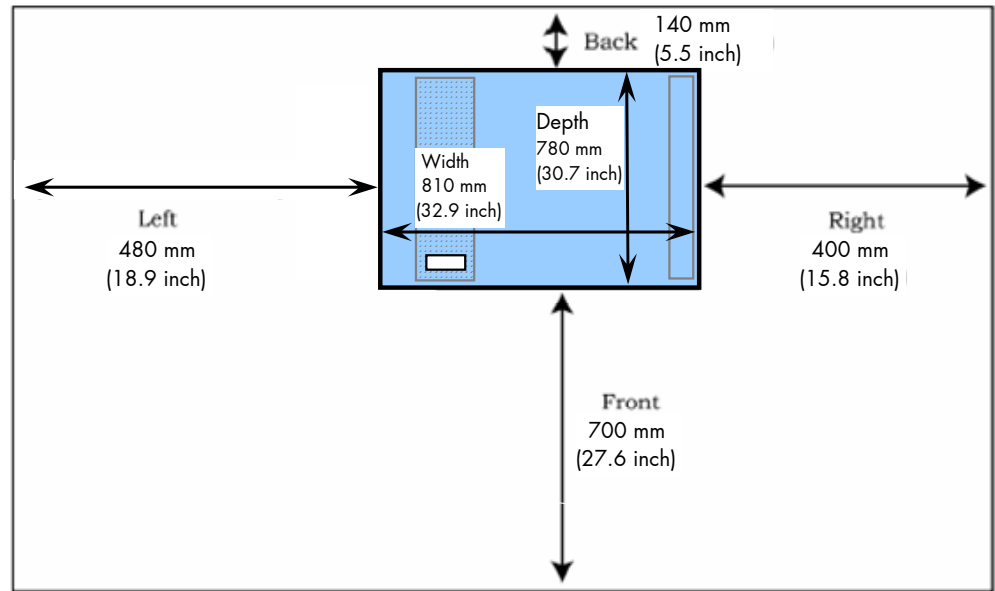

Fig. 2.3.a SOLID 33E-2 and SOLID 58E: Required space (plan view)



- The chosen location should be well ventilated.
During operating the printer produces ozone. The limiting value of 0.1 ppm (0.2 mg/m³) must not be exceeded. Please regard that ozone is heavier than air. If the room is ventilated well and the printer is maintained duly, the compliance with the limiting values is guaranteed.
Because of this the room assigned for the printer installation has to be well-ventilated, clean and dry.



- Damaging environmental factors such as metal vapors, oil mist, corrosive leaches or the like must not affect the printer.



- Place the printer on horizontal, firm and solid ground.
It must be ensured that the following horizontal inclination angle values are not exceeded:
 - from the printer's front to the rear $\pm 1^\circ$
 - from the left to the right $\pm 2^\circ$

- The horizontal position of the printer has to be adjusted accurately.
- At the side of the paper outlet there should be room enough so that the paper can flow out of the printer without hindrance.
- Do not expose the printer to shocks or vibrations.
- There must be enough room on all sides of the printer to guarantee necessary ventilation.



- Do not expose the printer to abrupt temperature changes.
- The printer should not be located near volatile or combustible materials (e.g. a curtain).
- Avoid locating the printer close to an air current (e.g. ventilators).
- The printer should not be exposed to direct sunlight.
- Do not touch the drum surface because the material is easy to damage.
- In order to run the printer reliably, please maintain the following environmental conditions:

Temperature: +15°C (56.5°F) to +30°C (86°F) (operating)
+19°C (68°F) to +23°C (73°F) (optimal operating)
-20°C (-4°F) to +40°C (104°F) (non-operating)

Relative atmospheric humidity: 25% to 55% (operating)
33% to 47% (optimal operating)
up to 95% (at +40°C; non-operating)

- For the storage of the consumables (toner e.g.) the following conditions are valid:
Temperature: -20°C (-4°F) to +40°C (104°F)
Relative atmospheric humidity: to 95% (at +40°C)
- For the storage of fanfold paper the following conditions are valid:
Temperature: 19°C (68°F) to +23°C (73°F)
Relative atmospheric humidity: 33 to 47%

Power standards:



- Please connect the power plug to
230 V AC, 50 Hz (Europe, United Kingdom e.g.)
115 V AC, 60 Hz (North America).
- The voltage support must not be impaired by interference.
- Use the printer only within the allowed fluctuation range of $\pm 10\%$ of the power voltage.

2.4. Printer Installation Instructions

Note:

If any of the following installation steps have already been carried out, please disregard the instructions concerning them.



The printer's **first installation** has to be done **by a trained service engineer**.



Please retain the original packing materials in case the printer has to be transported in the future. Use the original packing materials and adhesive fasteners to avoid damage to the internal components.

(See chapter 9 Measures for Transport and Shipping (Repacking)).

2.4.1. Opening the Printer

1. The printer is presumed to be switched off!
2. It is assumed that all transport locks are removed.
(Details are contained in the Service Manual.)
2. Open the printer's front cover.

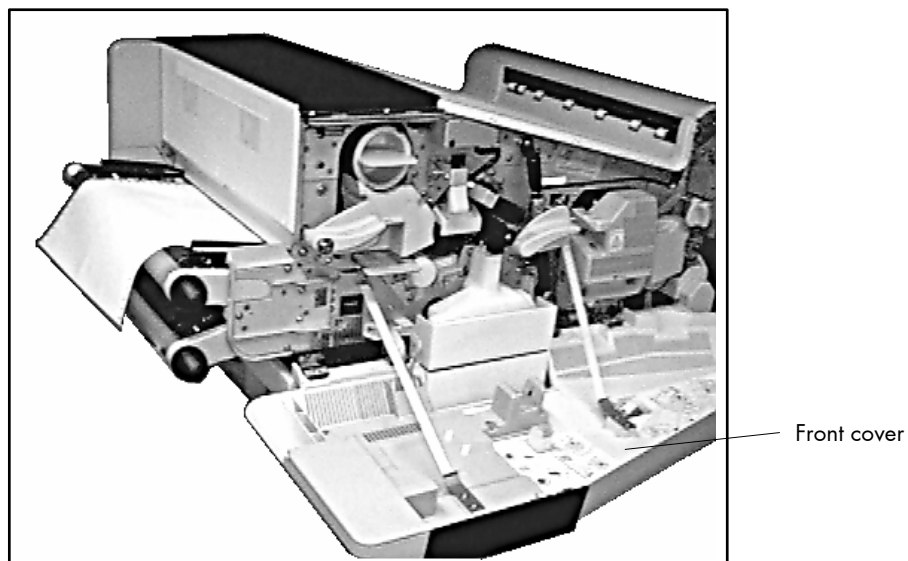

Fig. 2.4.1.a Printer opened

2.4.2. Loading the Developer Unit



The developer unit is already in the printer.

1. The printer's front cover is assumed to be opened.

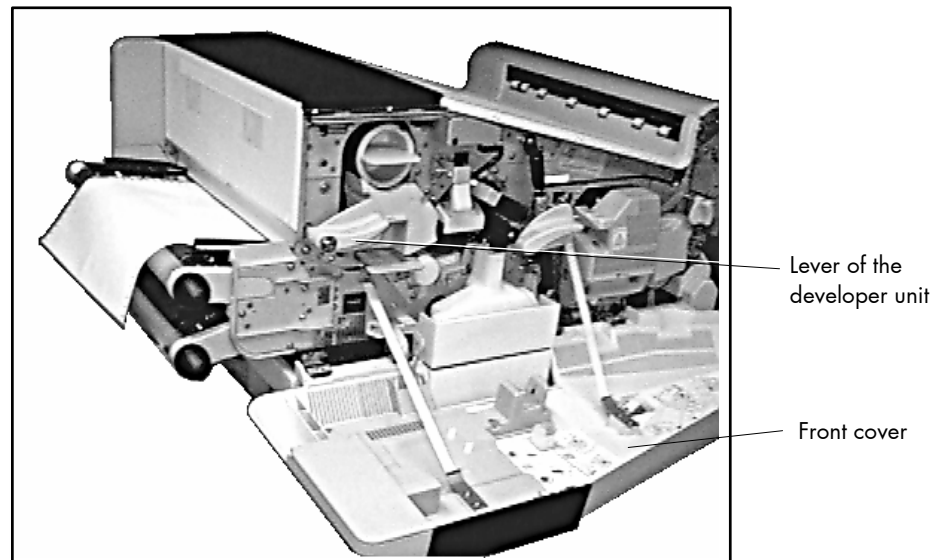

Fig. 2.4.2.a Printer opened

2. Rotate the lever of the developer unit counterclockwise to unlock the developer unit. (See figure 2.4.2.a and figure 2.4.2.b.)



Fig. 2.4.2.b Detail: Unlocking the developer unit

3. Pull the developer unit about 2/3 out of the housing.

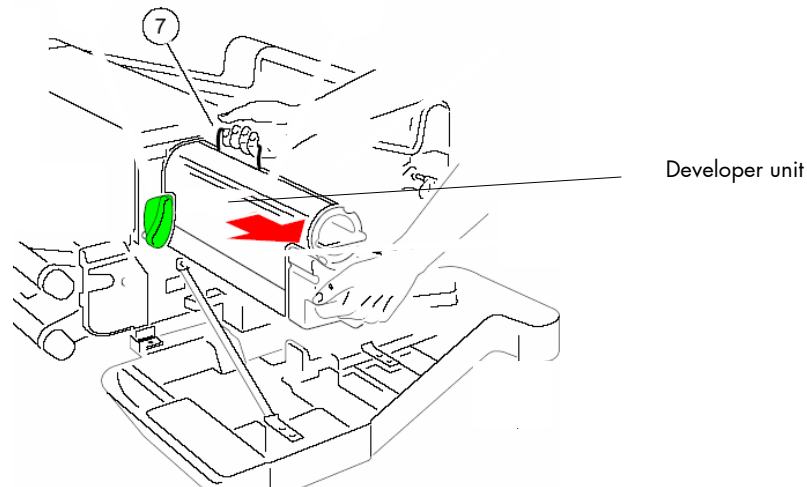

Fig. 2.4.2.c Taking out the developer unit

4. Grasp the grip (7) with the other hand and remove the developer unit from the printer.
5. Remove the plastic bag from the clutch on the rear side of the developer unit.
6. Remove plastic and paper safety strips from the area of the toner output of the developer unit.

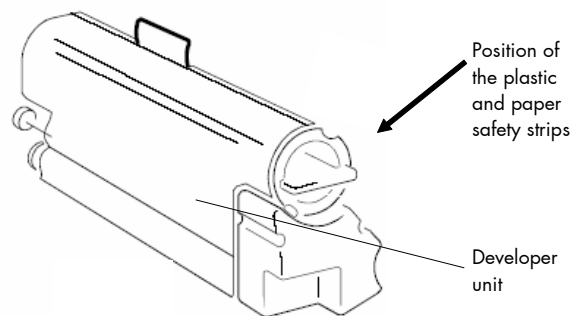

Fig. 2.4.2.d Position of the safety strips



Note: Don't destroy the small plastic lip above the toner output of the developer unit.

7. Now take the developer unit and position it in front of the corresponding opening of the printer.

8. Slide the developer unit back into the printer. (Compare figure 2.4.2.c)
9. Slowly push the developer unit into the printer until it stops.
10. Secure the developer unit by rotating the lever clockwise. (Compare figure 2.4.2.b)

2.4.3. Activating the Toner Cartridge



There is a toner cartridge in the developer unit.

1. Use the handle (see the following figure) to rotate the toner cartridge clockwise until it stops.

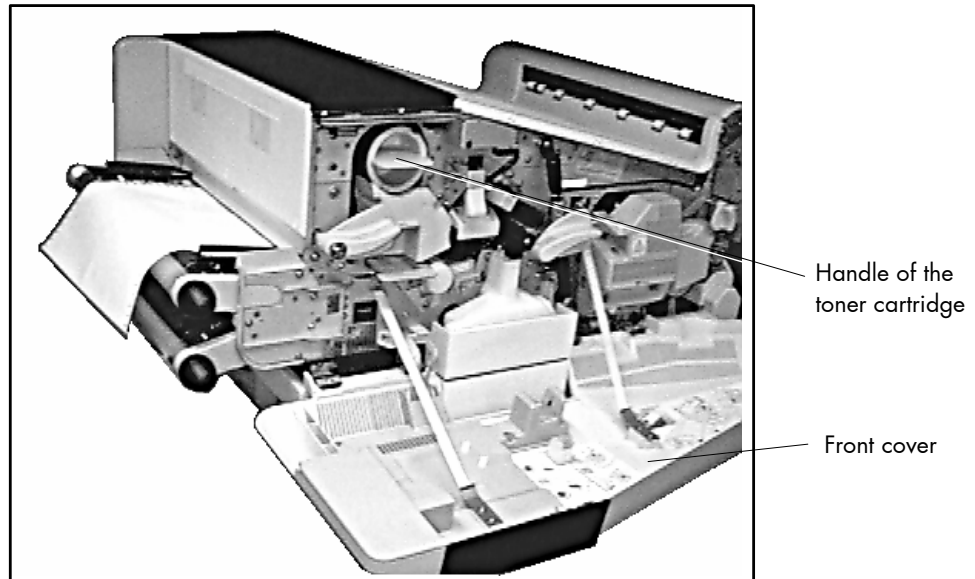

Fig. 2.4.3.a Position of the toner cartridge

2. Slowly pull the toner cartridge out of the printer.

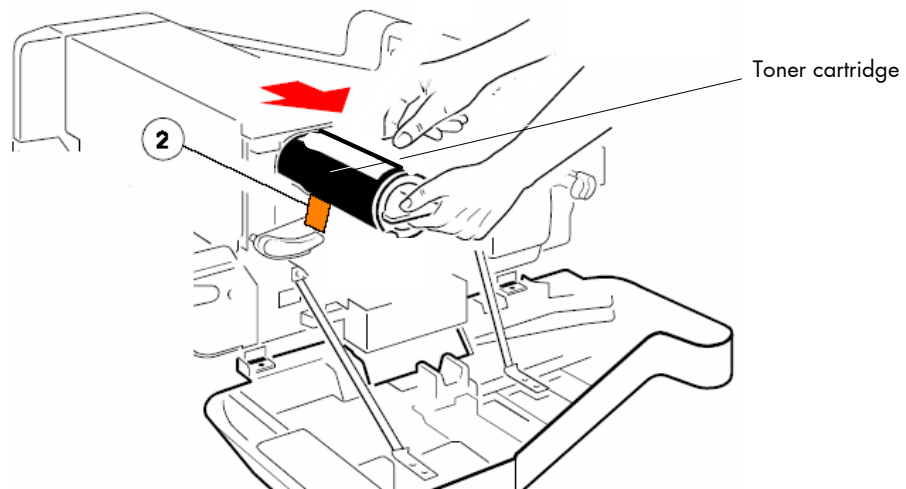

Fig. 2.4.3.b Pulling out the toner cartridge



Note: An orange tape (2) is visible which is fixed to a foam block that closes the toner entrance into the developer. (Compare fig. 2.4.3.b.)

3. Remove the foam block (2) from the developer unit.
4. Hold the toner cartridge as shown in the following figure and shake it gently by performing horizontal movements to distribute the toner.

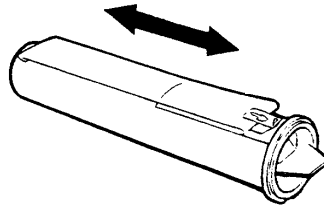

Fig. 2.4.3.c Shaking the toner cartridge

5. Now take the toner cartridge and position it in front of the corresponding opening of the printer.
6. Insert the toner cartridge approximate 10 cm into the printer, illustrated below, with the attached plastic seal (3) pointing to the top.

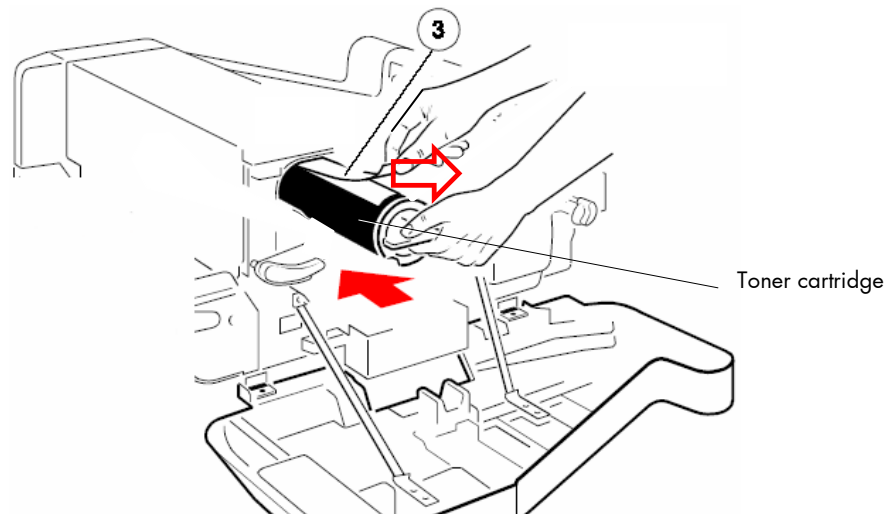

Fig. 2.4.3.d Inserting the toner cartridge

7. Slide the toner cartridge slowly into the device and pull off the plastic seal (adhesive tape) at the same time. (See arrows in the figure above.)

Hint: Roll or fold the sealing strip as you pull. This avoids snapping the sealing strip when it reaches the end of the toner cartridge and scattering any loose toner on the sealing strip.

8. Remove the adhesive tape completely.
9. Slowly push the toner cartridge into the developer unit until it stops.

Dropping toner into the developer unit

10. Now rotate the toner cartridge slowly about 180° counterclockwise (until it touches; compare fig. 2.4.3.e).



The cap of the toner cartridge must be located behind the "nose" (before the turning of the toner cartridge the "notch" in the cap enables the passing of the "nose").

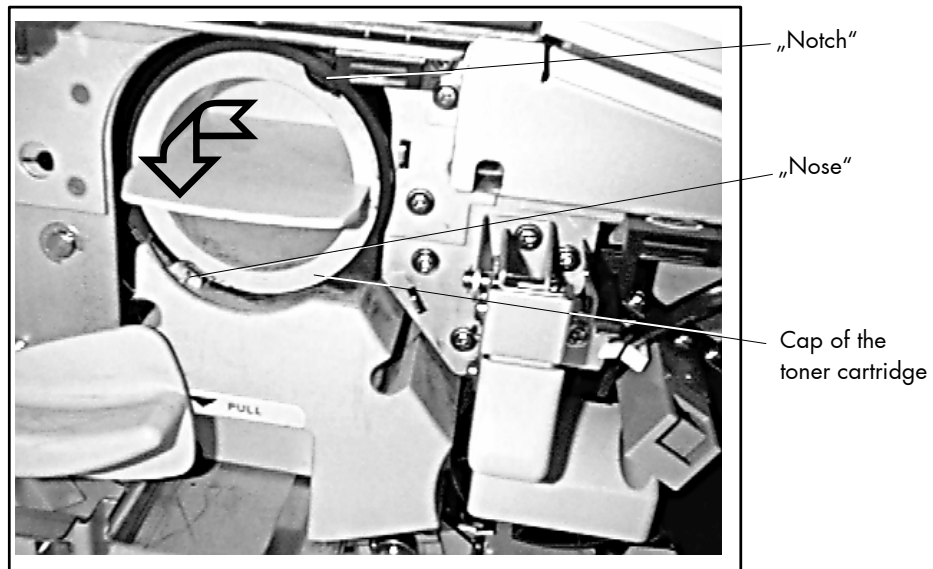

Fig. 2.4.3.e Locking the toner cartridge

The rotation of the toner cartridge effects that the toner falls out of the toner cartridge into the developer unit.

Now the toner cartridge's handle should be horizontal and the toner cartridge is locked into position.

2.4.4. Inserting the Waste Toner Bottle



The waste toner bottle is in the starter kit package (compare section 2.1 Check List).

1. Open the printer's rear cover.
2. Press the lever (see the following figure) to open the printer's top cover.

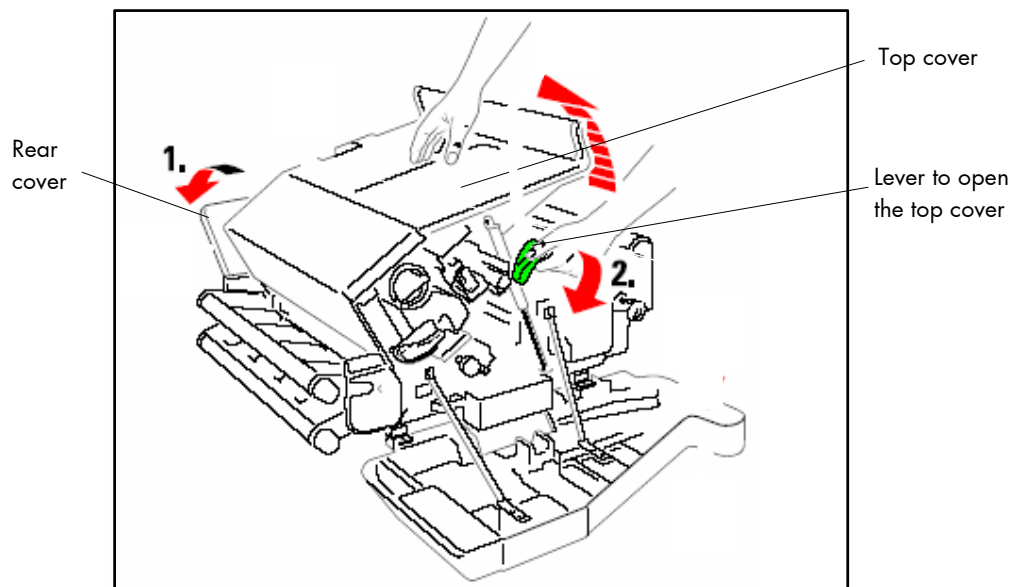

Fig. 2.4.4.a Opening the rear and top cover

3. Take off the cap from the waste toner bottle and place it to the bottles cap holder.

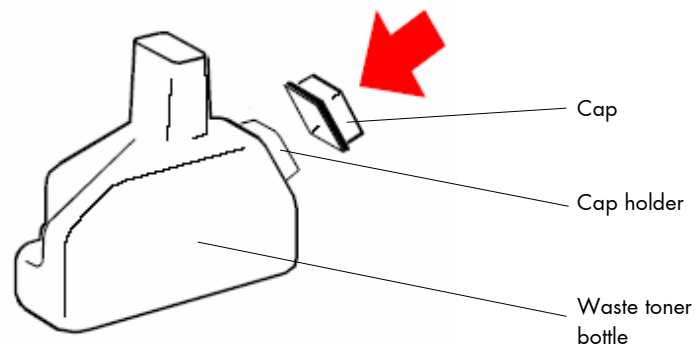

Fig. 2.4.4.b Preparing the waste toner bottle

4. Insert the waste toner bottle into the printer as shown in the following figure.

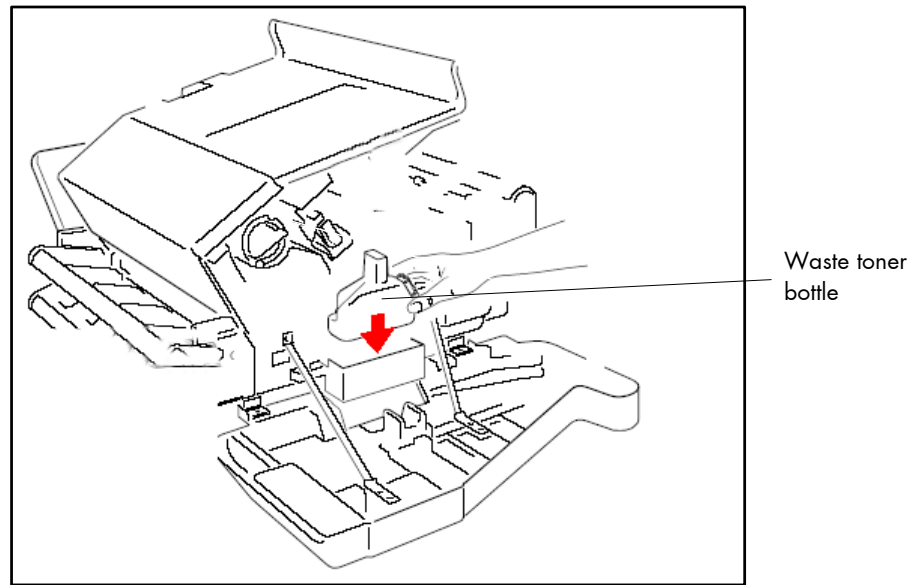

Fig. 2.4.4.c Inserting the waste toner bottle

2.4.5. Inserting the Cleaner Felt



The cleaner felt is in the starter kit package (compare section 2.1 Check List).

1. Insert the cleaner felt into the fuser unit.

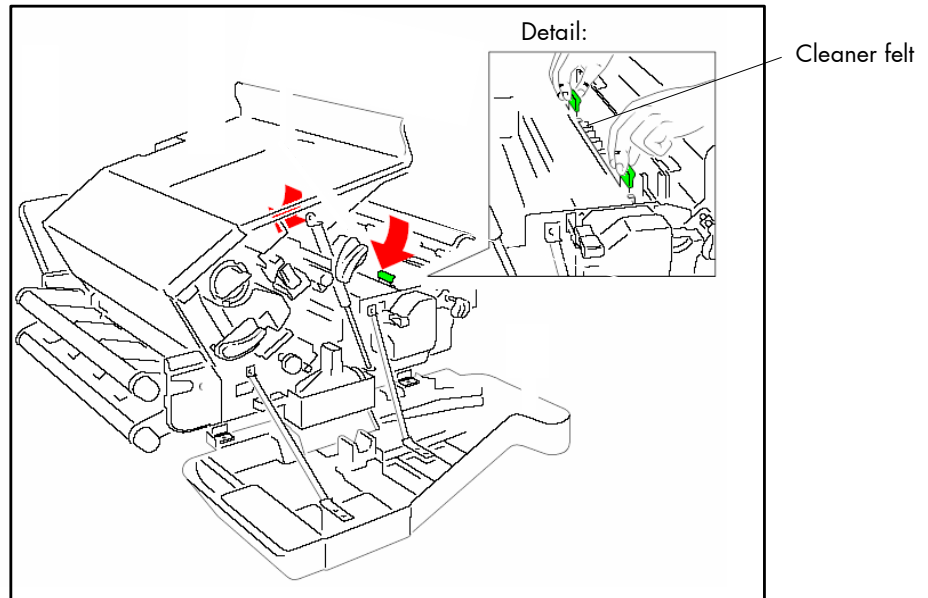

Fig. 2.4.5.a Inserting the cleaner felt



Note: Depending on paper properties it may be necessary to change the cleaner felt more often than with every second toner cartridge.

2. Close the printer's top cover.

2.4.6. Inserting the Ozone Filter



The ozone filter is in the starter kit package (compare section 2.1 Check List).

1. Insert the ozone filter into the slot.

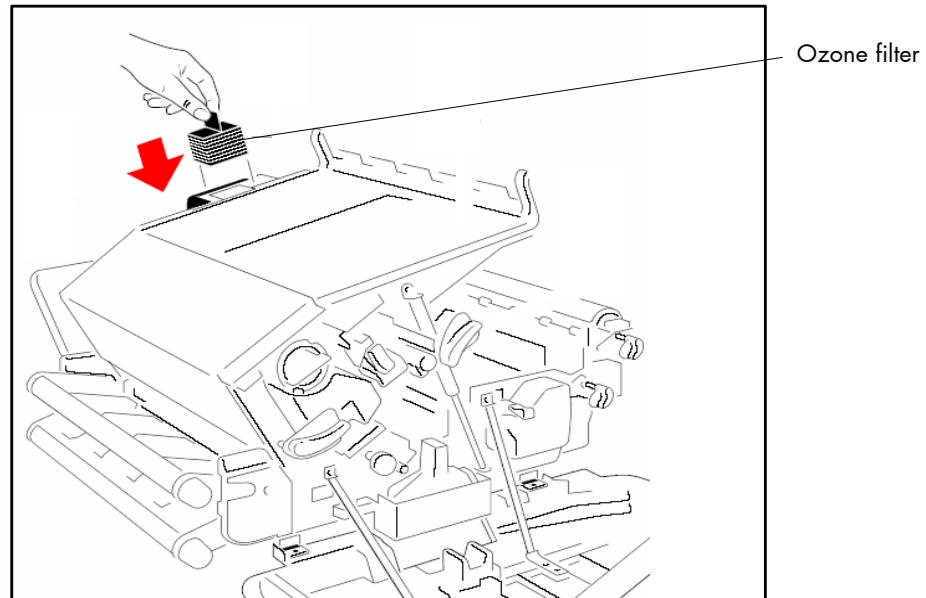

Fig. 2.4.6.a Inserting the ozone filter

2. Close the printer's rear cover.

2.4.7. Installing the PC Cartridge (OPC)



The PC cartridge (photoconductor) is in the starter kit package (compare section 2.1 Check List).



Note:

- The photoconductor is very light-sensitive, so it is wrapped in a lightproof foil.
- Please do not touch the green part of the photoconductor with your fingers. Oil and dirt degrade the print quality.
- Do not expose the light-sensitive photoconductor to room lighting or sunlight any longer than necessary.

1. Rotate the lever counterclockwise to unlock the developer unit.
2. Carefully remove the drum from its foil container.

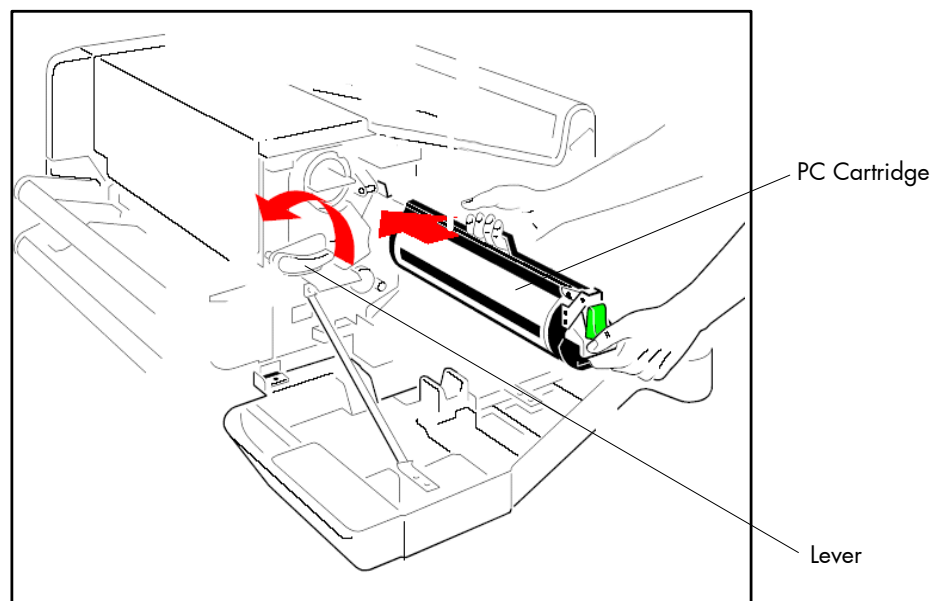

Fig. 2.4.7.a Unlocking the developer unit and inserting the PC cartridge

3. Insert the PC cartridge by using the upper and lower iron band guides and push it into the printer until you hear a click.
4. Attach the electrical connector of the PC cartridge to the printer.

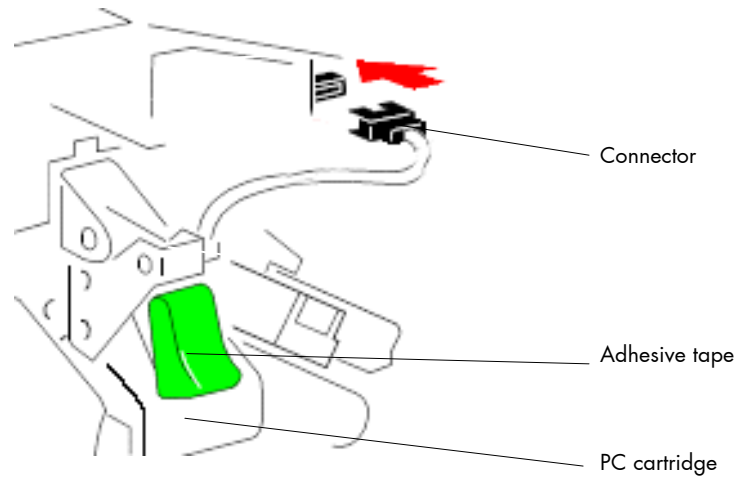
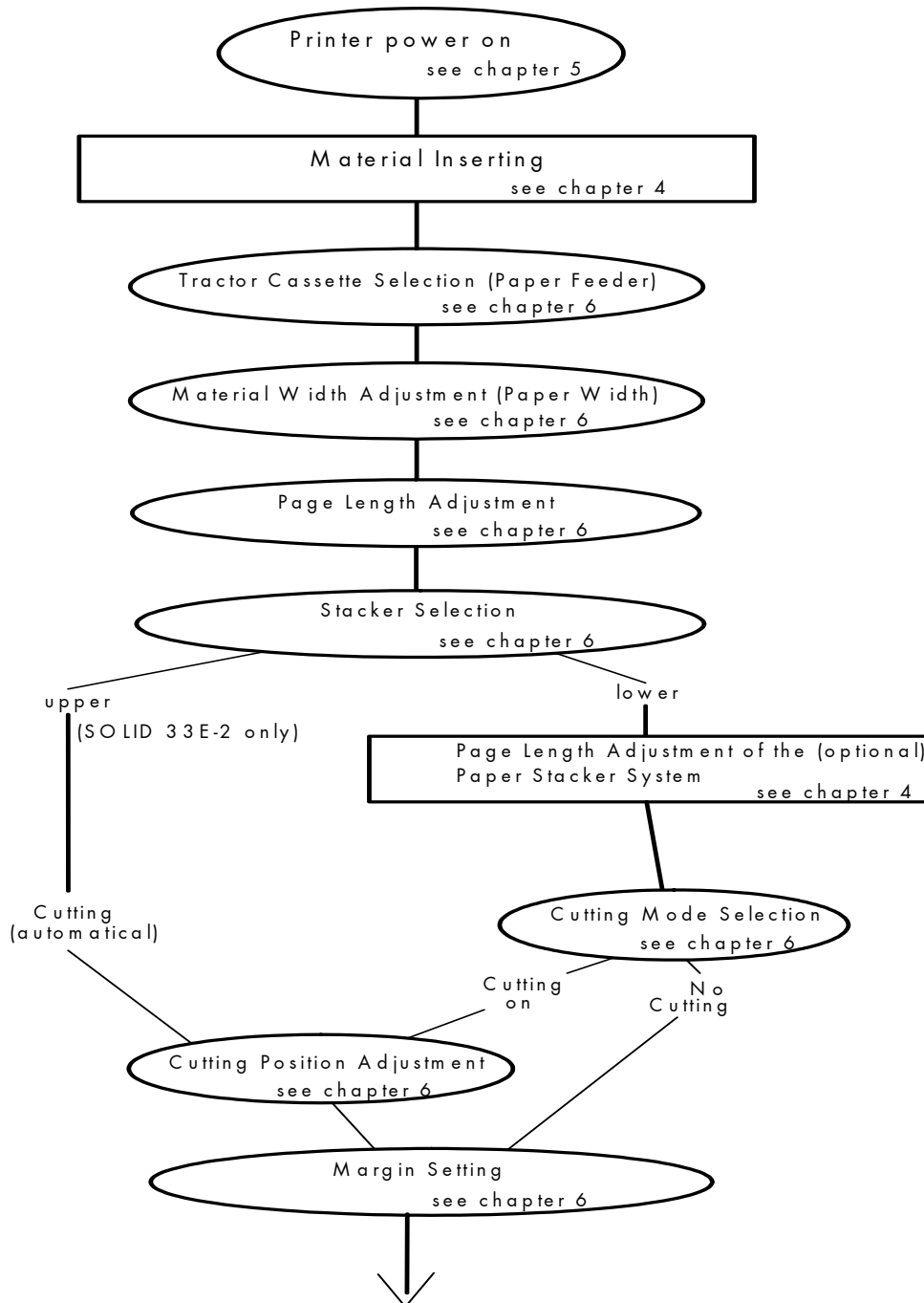

Fig. 2.4.7.b Attaching the electrical connector

5. Find the adhesive tape on the waste toner exit of the PC cartridge and remove it.
6. Secure the developer unit by rotating the lever clockwise.
7. Close the printer's front cover.

3. Basic Operation Sequences

3.1. Overview





If the control panel settings mentioned above should be effective permanently (that means they do not have to be put in again after every power OFF/ON) the setting values have to be saved permanently by pressing the BUTTON two times.
(More details can be found in chapter 5.)

An output of the current setting values can be released by activating the panel function "Printing the Status Sheet" (see section 6.1).

Detailed information on the operation sequences and to additional SOLID 33E-2 and SOLID 58E functions can be found in the following sections.

4. Handling of Consumables

If the printer is operated without the automatic paper stacker system (compare fig. 2.3.a) it has to be located at the front edge of a table.

Please make sure, the paper outlet is not obstructed by the power cord or the interface cord.

4.1. Feeding of Continuous Materials

4.1.1. Handling of the Tractor Cassettes

The printer is provided with two tractors for fanfold paper. The tractors are installed as separate feeding systems at the printer (see figure below).

Because of this they are called tractor cassettes from now on.

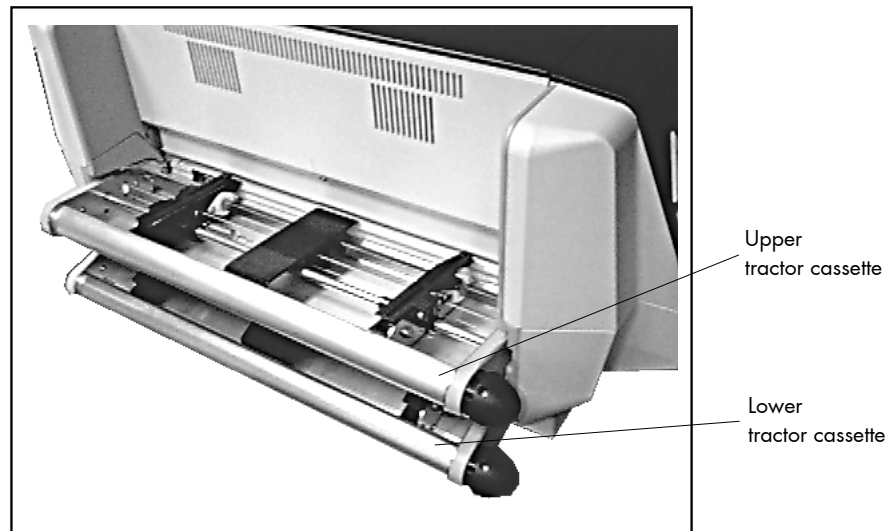

Fig. 4.1.1.a Tractor cassette position

To install the tractor cassettes they have to be slid into the assigned guide-ways until they click into place.

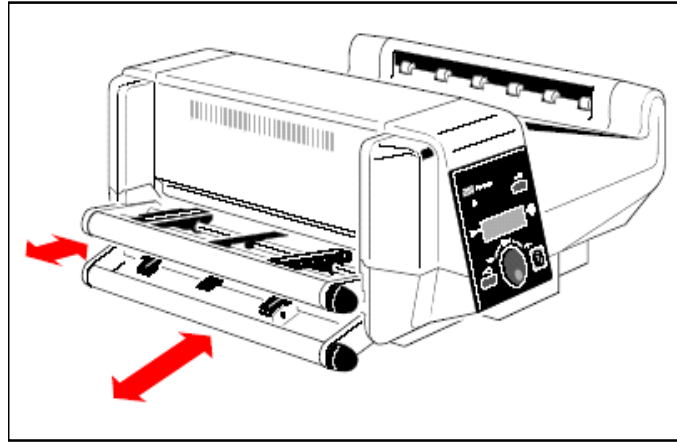

Fig. 4.1.1.b Handling of the tractor cassettes

The tractor cassettes can be removed from the guide-ways by lifting them gently.



The second tractor cassette located below is easier to install if the upper cassette was removed before.

If more than two different paper sizes have to be processed, it is recommendable to use additional tractor cassettes. These can be adjusted to the corresponding paper sizes in advance. So they only have to be inserted into the printer if necessary.

Information:

The inserted tractor cassettes represent the two available "sources" (e.g. paper sources for continuous form) for the printer. By activating the panel function „Tractor Cassette Selection" (see chapter 6) you can determine the source the printer accesses currently.

A change of source can also be released by dispatching the corresponding (software) command via the interface.

4.1.2. Continuous Material Inserting

Both printers SOLID 33E-2 and SOLID 58E process continuous material with a page length from 3 to 24 inches (incl. automatic paper stacker system from 7 to 17 inches).

The SOLID 33E-2 processes a material width from 4 to 17 inches (432mm incl. paper margin with sprocket holes), a width of 16 inches maximum is printable.

The SOLID 58E processes a material width from 6 to 18 inches (457mm incl. paper margin with sprocket holes), a width of 17 inches maximum is printable.



If necessary check the printer's set page length by generating a status print or by using the panel function "Page Length Adjustment" (see chapter 6).



Fig. 4.1.2.a SOLID 33E-2 with automatic paper stacker system

The following describes media handling (fanfold paper) for the "**upper tractor**".

Similar steps have to be done when using the lower tractor. But please regard this:



The second tractor cassette located below is easier to fill if the upper cassette has been removed before.

1. Place the cardboard box containing the fanfold paper into the paper magazine appertaining to this tractor (see fig. 4.1.2.a).

Please make sure that the first sheet of the continuous paper has the complete page length.

2. Open both tractor covers (by positioning the left and right tractor cover into the upright position, see figure below).

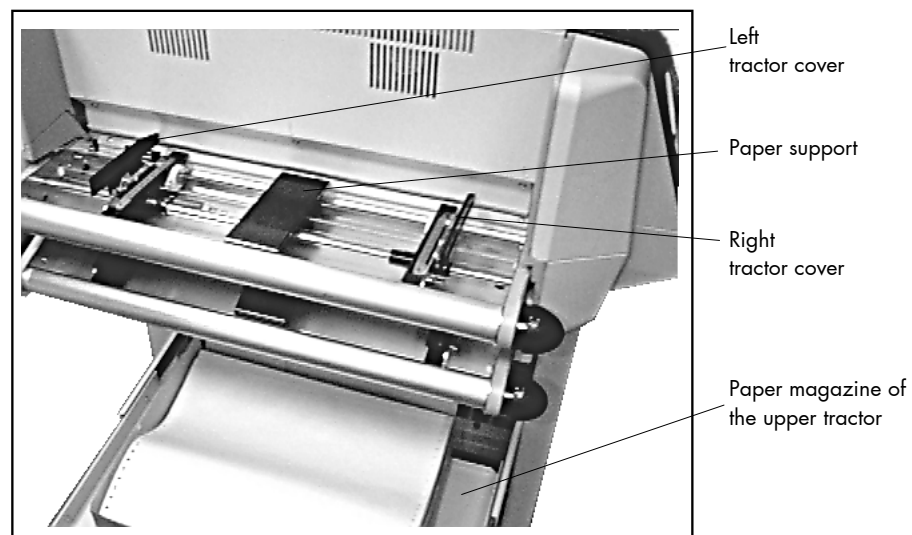

Fig. 4.1.2.b Opening the tractor covers

3. Adjust the paper support to the middle between the tractors.
4. Adjust the tractor approximately to the new paper width. For this turn knob A (see figure 4.1.2.c) clockwise (for narrow paper) or counterclockwise (for wide paper).

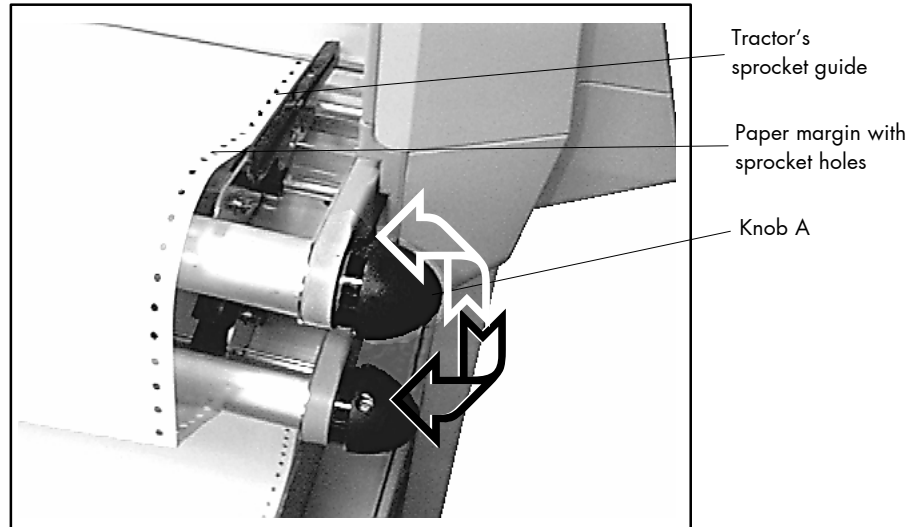

Fig. 4.1.2.c Adjusting the upper tractor to the paper width

5. Place the paper on the tractor as shown in fig. 4.1.2.c and 4.1.2.d.

The paper edge should reach into the printer's paper inlet (about three holes overlapping the tractor).

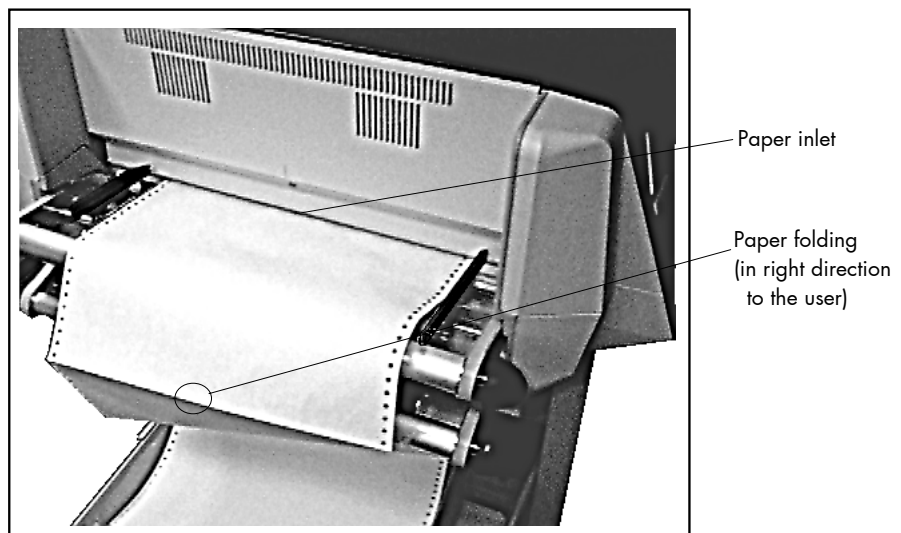

Fig. 4.1.2.d Paper inserting



6. To avoid a paper jam the folding (also called perforation) between the first and second sheet should point to the user (see figure above). If the folding does not point in direction to the user after the inserting the first sheet has to be detached and the inserting operation has to be repeated.

7. Check that the fold behind the first page points outwards to the user:

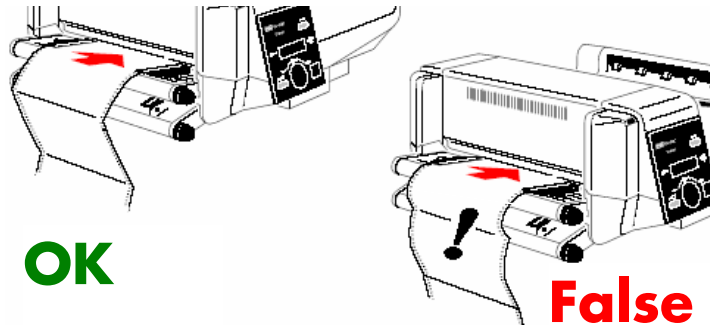

Fig. 4.1.2.e Checking the fold

8. Close one of the tractor covers.
9. Pull out and turn the knob A clockwise (small paper) or counterclockwise (wide paper) to adjust the tractors to the accurate paper width. (Hint: pull knob A until it touches and gently turn the knob while pulled; see figure below).



After this the pins of the tractor must be centered in the transport punches of the fanfold paper.

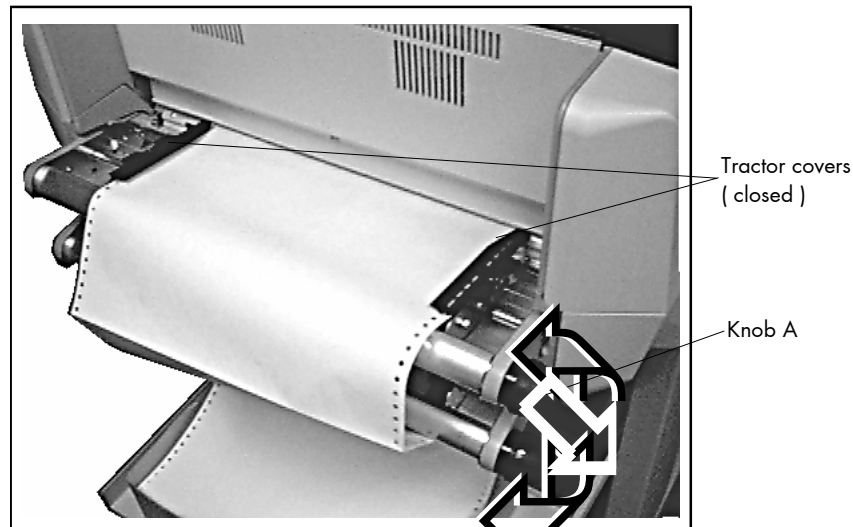

Fig. 4.1.2.f Adjusting the tractor to the accurate paper width



To avoid a paper jam the paper must neither be placed too loose nor too tight onto the tractor.

The paper edge has to reach into the printer's paper inlet as described above.

10. Close the second tractor cover.
11. Adjust the printer to the new paper size if necessary (see chapter 6).
12. Adjust the automatic paper stacker system to the new paper size if necessary (see section 4.2.3).

The inserted paper will be transported automatically to the start position for printing. This operation is started by the printer as soon as this tractor cassette is selected, the ONLINE key is pressed and a print job is sent.

4.1.3. Material Supply Changing

If the printer has already accessed to one of the tractor cassettes but you have decided to print another material please perform the following steps:

1. Turn the printer OFF LINE.
2. Use the KEY key to cut the "old" material. (See chapter 5 and chapter 6 for more details.
3. Change the paper source by either
 - a) selecting the other tractor cassette with the panel function "Tractor Cassette Selecting" (see section 6.8)
or
 - b) by removing the tractor cassette used so far and inserting a new one with the new material
or
 - c) by taking the "old" material from the tractor cassette used so far (it is possible without any other operating steps after the opening of the tractor covers) and by inserting the new material (as described in section 4.1.2).
4. Adjust the printer to the new paper size if necessary (see chapter 6).
5. Adjust the automatic paper stacker system to the new paper size if necessary (see section 4.2.3).

4.2. Printed Material Output

4.2.1. Paper Stacker Selecting

The SOLID 58E is provided with one outlet for printed material (compare fig. 2.3.a). The outlet on the right below is suitable for continuous material and also for cutsheet paper.

The SOLID 33E-2 is provided with a second separate outlet (compare fig. 2.3.a). The outlet on the right above is only suitable for stacking cut material.

By using the panel function "Stacker Selection" (see chapter 6) the current stacker can be determined.

Of course a stacker change is also possible with a corresponding command (via the interface).

4.2.2. Cutter Using

SOLID 33E-2 and SOLID 58E printers are provided with an internal cutter. The cutter can be used for separating print jobs and also for cutting continuous paper into single sheets.

When using the outlet on the right below the printed material will be stacked as continuous material automatically.

If certain print jobs are to be separated use the Key key or select the panel function "Autom.Cutting".

For detailed information about this panel functions see chapter 6. The panel function "Autom.Cutting" (resp. the corresponding command via interface) enables you to cut continuous material into single sheets during the print process and to stack them on the right below.

When using the paper stacker on the right above (SOLID 33E-2 only), the continuous paper will be cut in single sheets automatically.

The cutting process is released automatically corresponding to the set paper size when the sheet passes the cutter.

Subsequently the cut off paper is transported face down into the stacker on the right above.



If, for some reason, it is not desired to cut exactly on the perforation it is very important to cut below the perforation. If the paper is cut above the perforation the remaining paper can easily bend and cause a paper jam.

(See panel function "Adjusting the Cutting Position", chapter 6).

Do not cut through a label as the blade would get dirty by the glue.

4.2.3. Operating the Automatic Paper Stacker System



Only attach or remove the interface cable between stacker system and printer when the printer is switched off.

Using the automatic paper stacker system presumes the folding between the first and second sheet points to the user when inserting the continuous material (see section 4.1.2).

4.2.3.1. Adjusting the Paper Stacker to the Page Length

For a proper stacking of the continuous material the paper stacker system has to be adjusted to the paper size of the material to be printed on. You can do this by shifting the halves of the frame (see fig. 4.1.2.a and compare 4.2.3.1.a).

Steps to perform:

1. Loosen the two tightening screws (turn counterclockwise, see the following figure).

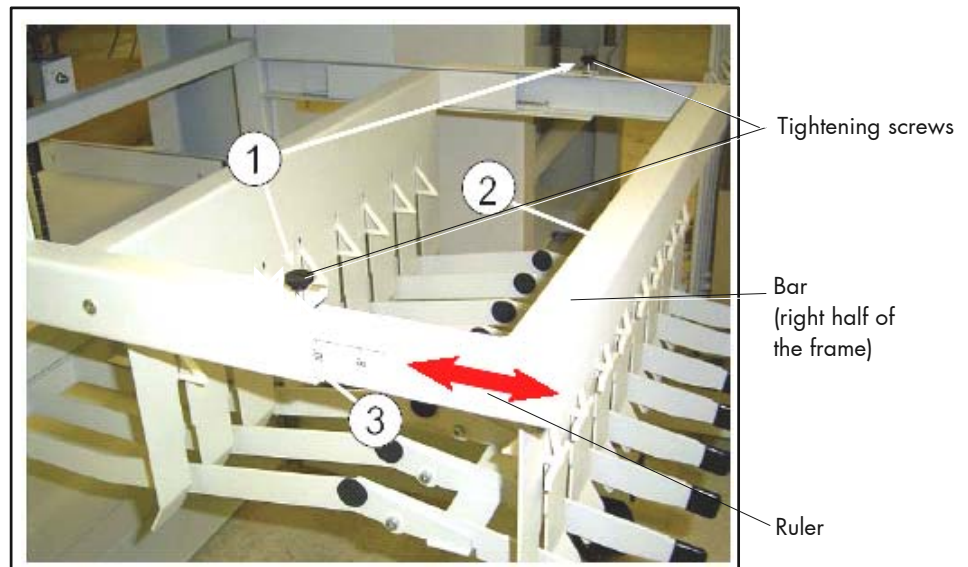

Fig. 4.2.3.1.a Adjusting the paper stacker system to the paper size

2. Move the bar (2) until the required length is visible on the ruler (3). You can adjust paper sizes from 7 up to 17 inches.
3. Tighten the two tightening screws.

4.2.3.2. Taking Printed Material from the Paper Stacker System

Ahead of the table top of the paper stacker system you can find the switch for driving up and down the stacking lattice (see fig. 4.2.3.2.a: switch A).

1. Operate the switch to drive down the stacking lattice (paper stacker tray).

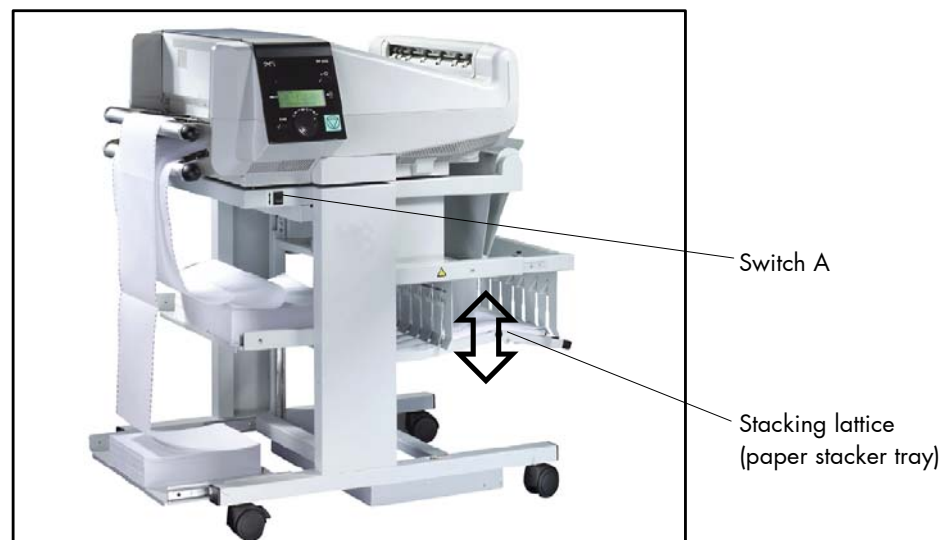

Fig. 4.2.3.2.a Driving down the stacking lattice

2. Remove the printed material.

After 30 seconds or when a next print job is processed the paper stacker tray is lifted automatically into the operating position.



For driving up and down the stacking lattice a chaindrive is used. Please keep your distance because the chaindrive can start automatically, too.

5. Operation and Menu Structure

5.1. Attaching the Printer to a Computer

1. Make sure the printer, computer, and any other attached devices are turned off and unplugged.
2. Use a proper interface line to connect the printer to the computer or to attach the printer to the network.
The printers SOLID 33E-2 and SOLID 58E are provided with several interfaces; see figure 2.2.c and chapter 10 Specifications for more information.

5.2. Turning on the Printer



Before you connect the printer to the main power, make sure that the voltage of the main power matches the printer's voltage requirement. The product label on the back of the printer certifies the printer's voltage.

1. Plug one end of the printer power cord into the socket at the back of the printer and the other end into a properly grounded outlet.



Fig. 5.2.a Turning on the printer (printer's rear view)

2. Turn on the printer.

The printer requires time to warm up after you turn it on. During this period, the message **[Please Wait]** appears on the control panel display.

After the printer completes its internal tests, the **[SOLID 33E-2]** or **[SOLID 58E]** message indicates the printer is ready to receive jobs.

If you see other messages on the display, refer to chapter 8 Troubleshooting for instructions on clearing the message.

Note: You can change the language that appears on the control panel display. Use the "Display Language Selection" panel function (see section 6.16).

5.3. Control Panel View

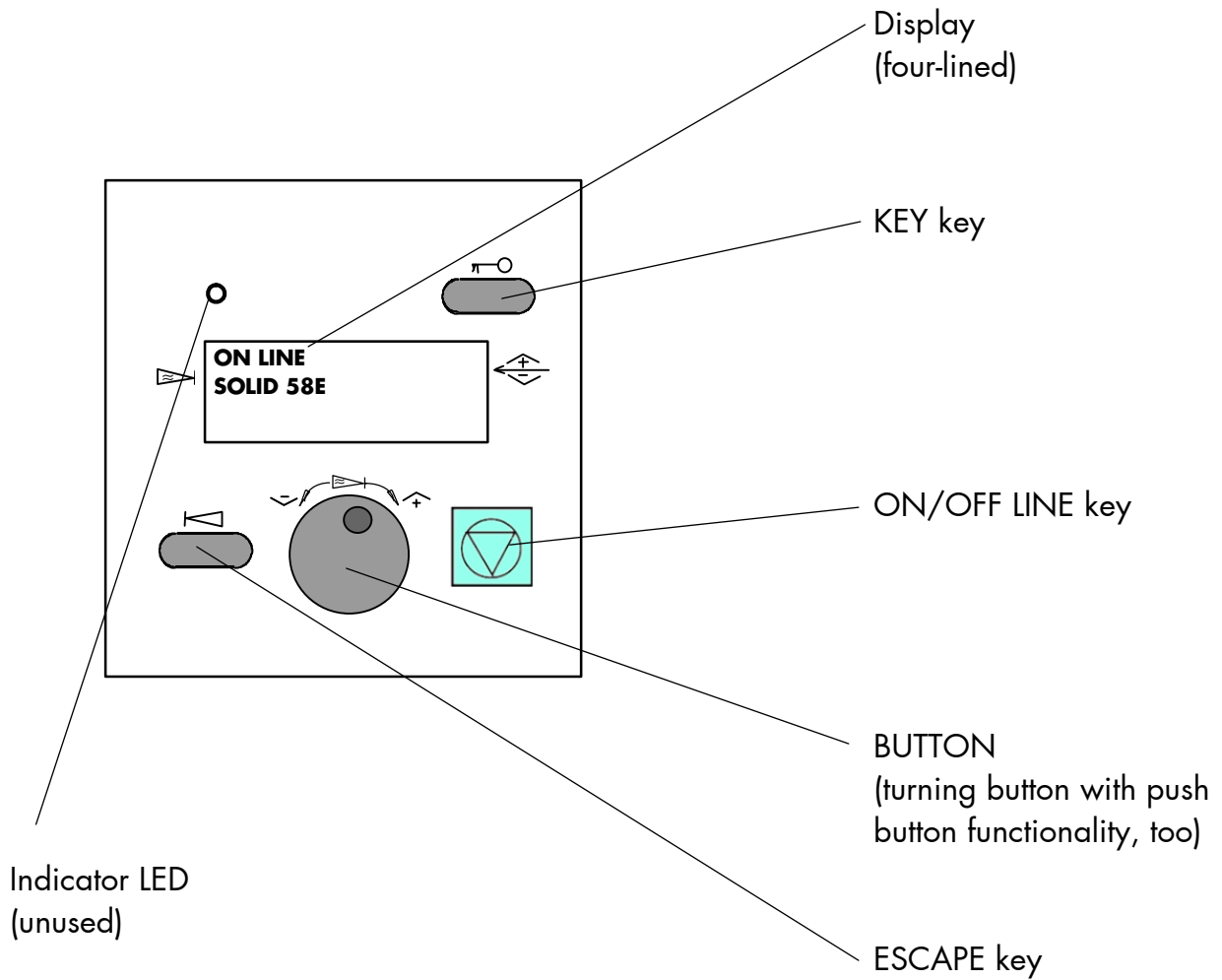

5.4. Function of the Control Panel Elements

Display

The four-lined display (panel) serves to show the printer's status messages.

Control Panel Keys



The ON LINE key turns the printer ON- / OFF LINE.

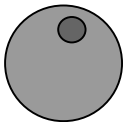

This symbol shows the turning button. This panel element comes with a push button functionality, too. This panel element is simply called **BUTTON** from now on.

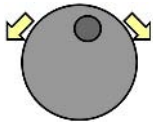

By turning the **BUTTON** to the left or right you can move within the menu levels. The menu structure and the panel functions are described in the following sections.



By pressing the **BUTTON** inputs are confirmed and functions released.

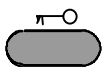

This symbol shows the **KEY** key.
In the OFF LINE mode this key is used to start the **cutter**.

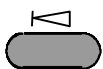

This symbol shows the **ESCAPE** key.
This key is used to get into the next (higher) level of the menu structure.

5.5. Configuration via the Control Panel

You can use the control panel to change the printer configuration and customize your printer to meet your specific needs.

In addition a software (called [IP_printADMIN](#)) will be available for the SOLID 33E-2 and SOLID 58E printers to allow a printer configuration via Ethernet.

The controller has its integrated website with information on the printer status and the printjob status.

Chapter 6 (Panel Functions) describes how to reach the particular printer functions via the control panel.

T e m p o r a r y changes in printer configuration are effective only as long as the printer stays turned on. To select such changes temporarily, the user must terminate the change of function by pressing the **BUTTON** one single time.

P e r m a n e n t changes in printer configuration are active each time the printer is turned on again. To select such changes permanently, the user must terminate the change of function by pressing the **BUTTON** **two times**.

An output of the current printer values can be generated using the panel function "Printing the Status Sheet" (see section 6.1).

Switching the Printer OFF LINE

After the printer was turned on (and as soon as the warm up phase is finished) the printer goes into the ON LINE – Mode.

A complete announcement of the four-lined display in the SOLID 33E-2 control panel looks like this:

in the ON LINE mode:

<u>Panel display</u>	<u>Notes</u>
[ON LINE] [SOLID 33E-2] [] []	Printer status

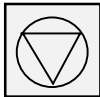

This symbol shows the ON/OFF LINE key. With this panel key the printer is turned OFF LINE and you get automatically to the first level of the menu structure.

SOLID 33E-2 in the OFF LINE mode:

<u>Panel display</u>	<u>Notes</u>
[OFF LINE] [Menu Level 1] [] []	Printer status Menu line

[Menu Level 1] In the interest of simplicity, in the following sections only the most important display messages are shown in the "Panel display" column.

5.6. Menu Structure

Access to the menu structure is possible as soon as the printer is turned OFF LINE.
 The menu structure of the SOLID 33E-2 and SOLID 58E is arranged in different levels:

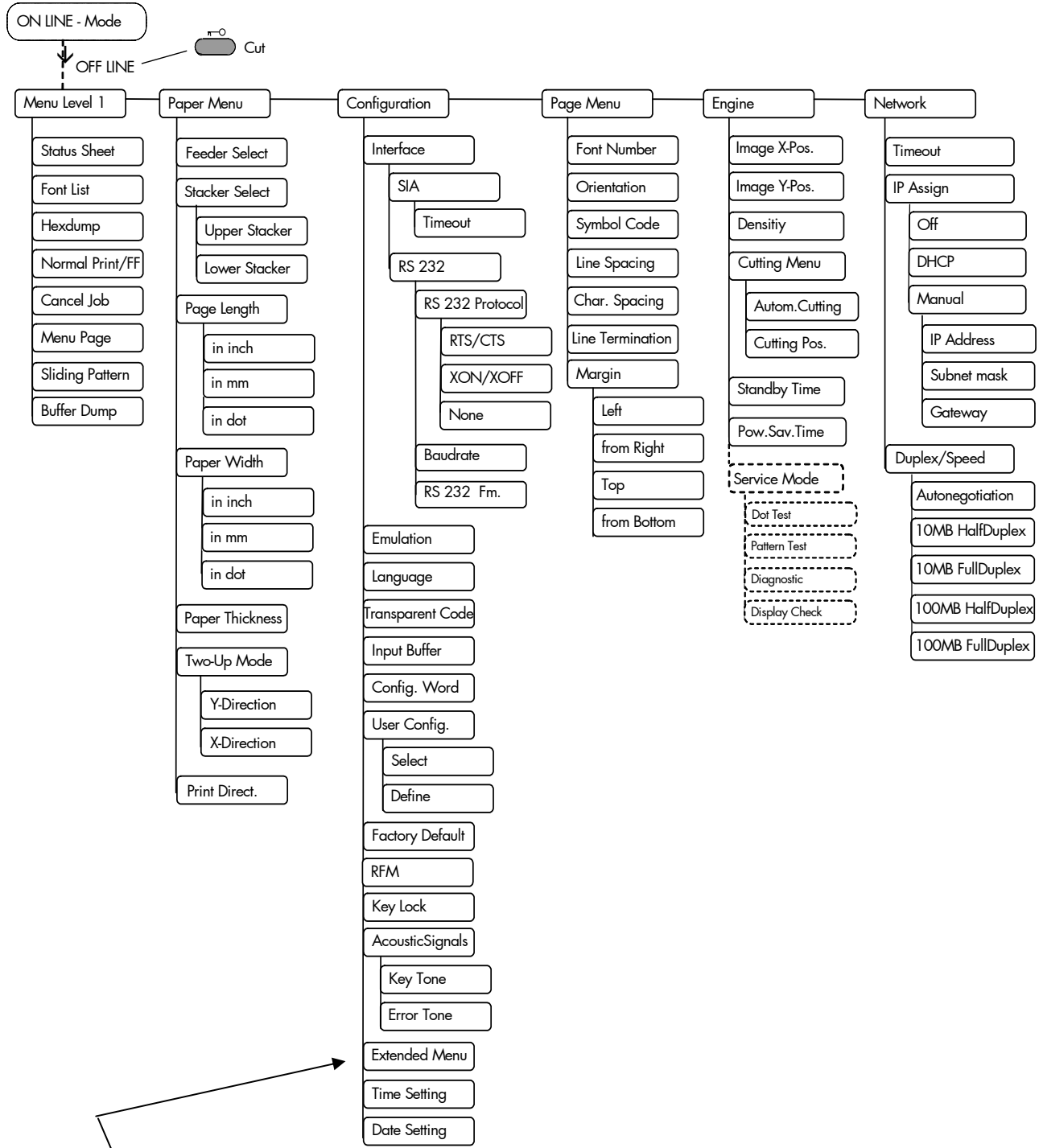

This panel function allows the user to choose a **reduced menu** instead of the extended menu shown above.

Selecting positions in the menu structure:

This symbol shows the ON LINE key. You get automatically into the first menu level, if the printer is turned OFF LINE with this key.

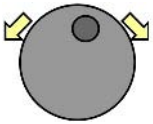

This symbol shows the BUTTON.
By turning the BUTTON to the left or right you can move within the menu levels.

["Menu Level"]

Each menu item/subitem within a menu level is shown in the display.



Pressing the BUTTON has two main functions. It gives the user access to a particular menu and, once in the menu, it allows the user to select a particular function.

["Function"]

Functions / Changing of function values:

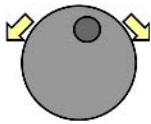

Within one function the value can be changed by turning the BUTTON to the left or right.

In case of a multi-digit function value the value of the currently chosen digit will be changed.



In case of a multi-digit function value pressing the BUTTON switches to the next position of the function value.

Pressing the ESCAPE key switches to the previous digit of the function value.

Please note: If you press the ESCAPE key although the absolute left digit of the function value is still arrived, the changing procedure will be cancelled and this moves you to the next menu level above.

If you press the BUTTON although the absolute right digit (digit 1) of the function value is still arrived, the currently displayed function value is stored.



Pressing the BUTTON the currently displayed function value is confirmed respectively the displayed function is activated. The changes are saved temporary. (This means, the changes are saved only until the next printer power off).

[Save as Setup?]

After this you have to decide, if you want to save the changes permanent (Save as setup).



To select such changes permanently, the user must press the BUTTON one more time. These permanent changes in printer configuration are active each time the printer is turned on again.

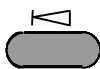

If the ESCAPE key is pressed instead, the changes are only stored temporary (not saved as setup). (This key takes the user to the respective previous menu level).

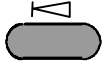
Return to the menu level above:

Pressing the ESCAPE key takes the user back to the respective menu level above.

Return to the ON LINE mode:

Pressing the ON LINE key switches the user directly to "ON LINE" from any menu position.

5.7. Syntax of Diagrams

The control panel functions will be described using diagrams. These diagrams show the course necessary in order to activate a certain function.

First the elements of the diagrams are explained:

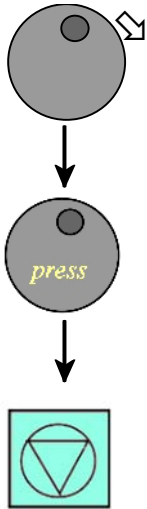

The sequence on the left describes which keys have to be pressed briefly in succession.

In this example the BUTTON has to be turned to the right (clockwise) first. Then the BUTTON has to be pressed. Then the BUTTON has to be released and the ON/OFF LINE key has to be pressed.

["Message"]

The "Panel display" column shows the display messages corresponding to the sequences listed on the left.

(In the interest of simplicity, in the following sections only the most important display messages are shown in the „Panel display“ column.)

In the column "Notes" explanations to particular operational steps are given.





6. Panel Functions



For the panel functions described in the following text, the printer is presumed to be switched on and in the ON LINE mode.

6.1. Printing the Status Sheet

This function generates a status sheet. The status sheet contains information about the current printer configuration, the available fonts and options.

	<u>Panel display</u>	<u>Notes</u>
	[SOLID 33E-2]	
		Turn the printer OFF LINE with this key.
	↓	
		[Menu Level 1]
	↓	
		[Status Sheet]
	↓	
		[Status Sheet]
	↓	
		The printer is turned ON LINE again.

Status sheet contents:

The first lines, entitled SERVICE INFORMATION, contain hexadecimal coded configuration parameters.





Printed in plain text:

- Controller version / memory / serial number
- Firmware release
- Interface
 - parameters of Parallel, Serial, USB, Network (Ethernet)
- Printer emulation
- User-RAM / free User-RAM
- Input data buffer
- Transparent code
- Paper size
- Default margins top / left
 bottom / right
- Default character code
- Options
- Fonts installed (Font banks)

Note: Use the panel function Printing the Font List to show the fonts installed (see the following section).





6.2. Printing the Font List

This function generates a list of all fonts installed to the printer. The font list shows demo prints of all fonts and, in addition, the concerning PCL selection commands. These commands contain information on font width and font height (see section 6.20 Font Selection, too).

	<u>Panel display</u>	<u>Notes</u>
	[SOLID 33E-2]	
		Turn the printer OFF LINE with this key.
↓		
	[Menu Level 1]	Menu Level 1 is selected.
↓		
	[Status Sheet]	Turn the BUTTON to the left or right until [Font List] is displayed.
↓		
	• • •	
↓		
	[Font List]	The font list is printed.
↓		
	[Font List]	The printer is turned ON LINE again.

6.3. Hexdump Mode Activation

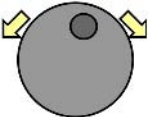









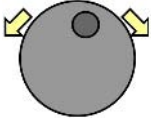

In the Hexdump Mode the printer prints all characters received via interface without any interpretation (hexadecimal coded). This mode helps with error diagnosis. The Hexdump Mode can be activated only temporarily.

	<u>Panel display</u>	<u>Notes</u>
	[SOLID 33E-2]	
		Turn the printer OFF LINE with this key.
↓		
	[Menu Level 1]	Menu Level 1 is selected.
↓		
	[Status Sheet]	
↓		
	...	Turn the BUTTON to the left or right until [Hexdump] is displayed.
↓		
	[Hexdump]	
↓		
	[Hexdump]	The Hexdump Mode is activated.
↓		
		The printer is turned ON LINE again.

Note: By activating the normal print mode (see next page) or by turning the printer off and on again the printer can be taken out of Hexdump Mode. Time between turning the printer off and on again should be at least 15 seconds.

6.4. Normal Print Mode Activation (incl. FORM FEED)

The normal print mode suspends the Hexdump Mode. This function is activated, when a print job must be continued without turning the printer off and on again. In addition to that the function "Normal Print Mode Activation" is used to produce a FORM FEED.







	<u>Panel display</u>	<u>Notes</u>
	[SOLID 33E-2]	
		
		Turn the printer OFF LINE with this key.
		
	[Menu Level 1]	Menu Level 1 is selected.
		
	[Status Sheet]	
		
	...	
		
	[Normal Print/FF]	Turn the BUTTON to the left or right until [Normal Print/FF] is displayed.
		
	[Normal Print/FF]	The normal print mode is activated.
		
		The printer is turned ON LINE again.

Note:

After activating the normal print mode a FORM FEED is released automatically and one sheet is put out. This is necessary because after a test in the Hexdump Mode it is possible that data can remain in the input buffer unintentionally (cause: in the Hexdump Mode no control characters are evaluated and no FORM FEED is effected).

6.5. Clearing the Input Buffer (Cancel Job)

This function permits the resumption of a print job at a particular page after a print interruption (e.g. paper jam). The data contained in the input buffer before the interruption are cleared.

<u>Panel display</u>	<u>Notes</u>
	[SOLID 33E-2]
↓	
	[Menu Level 1]
↓	
	[Status Sheet]
...	
↓	
	[Cancel Job]
↓	
	[Cancel Job]
↓	
	

Turn the printer OFF LINE with this key.

Menu Level 1 is selected.

Turn the BUTTON to the left or right until [Cancel Job] is displayed.





All data contained in the input buffer will be cleared.

The printer is turned ON LINE again.

6.6. Printing the Menu Page



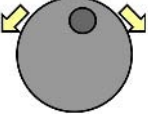



This function prints a survey of the available panel functions.

Note: When printing the menu page please use a large paper.

<u>Panel display</u>	<u>Notes</u>
	[SOLID 33E-2] Turn the printer OFF LINE with this key.
↓ 	[Menu Level 1] Menu Level 1 is selected.
↓ 	[Status Sheet] Turn the BUTTON to the left or right until [Menu Page] is displayed.
↓ ...	
↓ 	[Menu Page] A menu structure presentation of the SOLID 33E-2 (or SOLID 58E) is printed. (See section 5.6.)
↓ 	[Menu Page] The printer is turned ON LINE again.

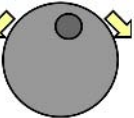



6.7. Generating Testsheets (Sliding Pattern)

This function generates a series of test prints without sending data to the printer.
These test prints facilitate error analysis.

<u>Panel display</u>	<u>Notes</u>
	
↓	
	[SOLID 33E-2] Turn the printer OFF LINE with this key.
↓	
	[Menu Level 1] Menu Level 1 is selected.
↓	
	[Status Sheet] Turn the BUTTON to the left or right until [Sliding Pattern] is displayed.
↓	
...	
	[Sliding Pattern] A series of test prints is generated.
↓	
	[Sliding Pattern] The printer is turned ON LINE again.
	The printing out of test prints can be stopped by pressing the ESCAPE key.

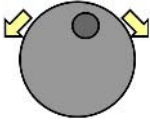
6.8. Tractor Cassette Selection (Feeder Select)

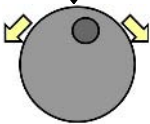
This function selects the tractor that transports the material to be printed on (e.g. paper) into the printer.

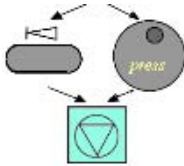
<u>Panel display</u>	<u>Notes</u>
	
↓	
	[Menu Level 1]
↓	
...	
↓	
	[Paper Menu]
↓	
	[Feeder Select]
↓	
	[Lower Tractor]
↓	
...	
↓	
	[Upper Tractor]
↓	
	[Save as Setup?]

Turn the printer OFF LINE with this key.

Turn the BUTTON to the left or right until [Paper Menu] is displayed.

Press the BUTTON to select the paper menu.

Press the BUTTON to select the paper feeder.

Turn the BUTTON to the left or right until the desired feeder is displayed.

The upper tractor is selected.

In addition this new value can be saved as setup value (using the BUTTON), before the printer is turned ON LINE again.

6.9. Stacker Selection

This function enables the user to choose a particular stacker.



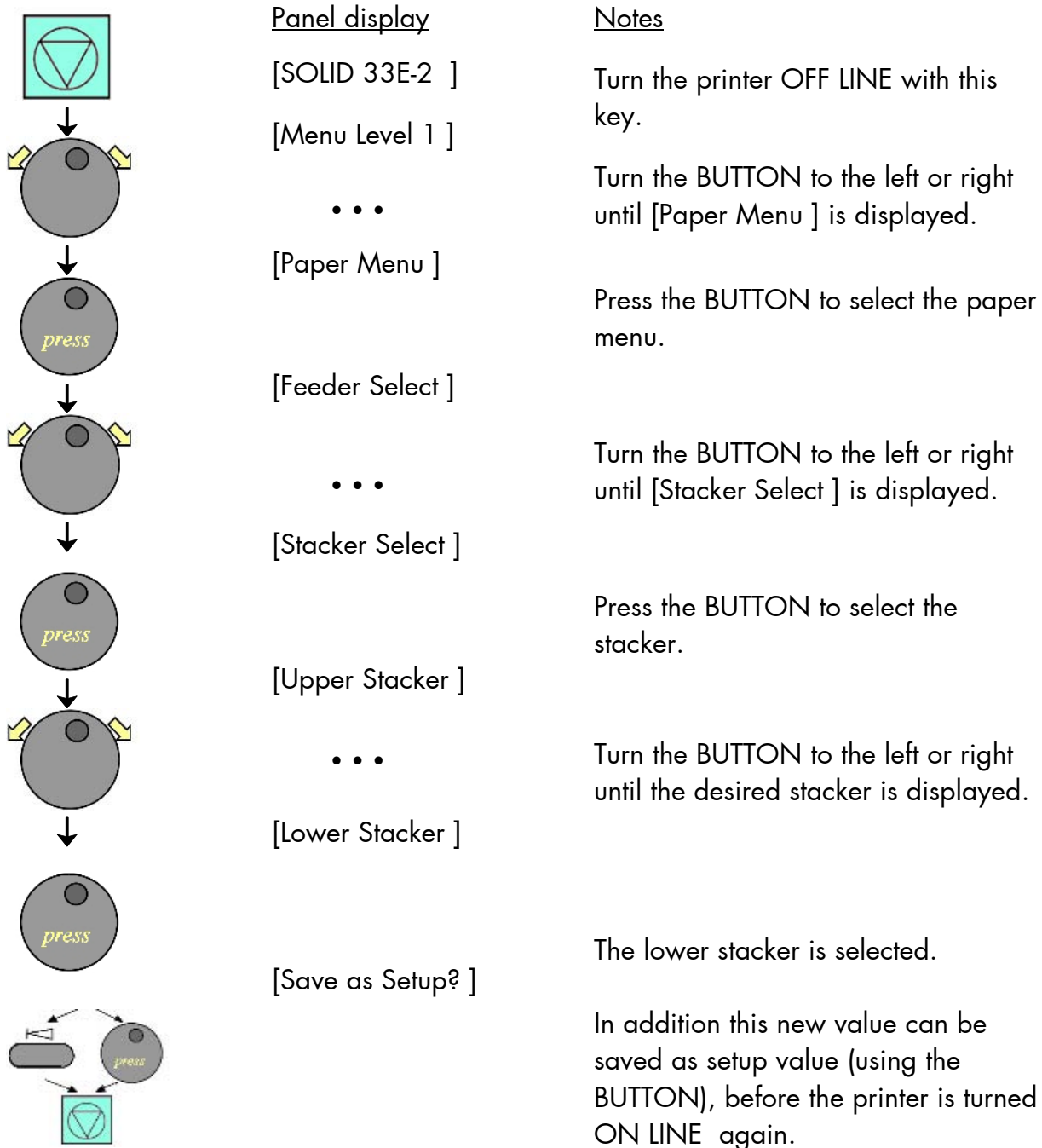

Note: When using the upper stacker (SOLID 33E-2 only) every sheet is cut off (not depending on the selected cutting mode, compare section 6.27).

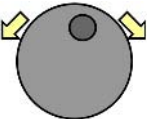

6.10. Page Length Adjusting

After having inserted new material to print on (e.g. paper) the paper size (the print format) has to be adjusted with this function corresponding to the currently used paper size.

The standard value for the paper size is 12 inches.

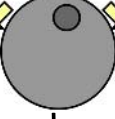
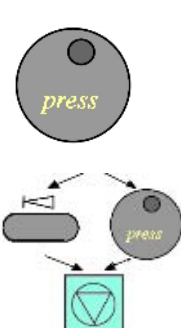
	<u>Panel display</u>	<u>Notes</u>
↓	[SOLID 33E-2]	Turn the printer OFF LINE with this key.
	[Menu Level 1]	Turn the BUTTON to the left or right until
↓	• • •	[Paper Menu] is displayed.
	[Paper Menu]	Press the BUTTON to select the paper menu.
↓	[Feeder Select]	
	• • •	Turn the BUTTON to the left or right until
↓	[Page Length]	[Page Length] is displayed.
	[in Inch]	Press the BUTTON to adjust the page length.
↓	[Digit4 12.00]	Inch = currently selected measuring unit (alternative the measuring units mm or dot can be chosen by turning the BUTTON).
	• • •	Turning the BUTTON to the left or right changes the value of the current digit (Digit4 = left digit, in the example: 1).
↓	[Digit1 12.33]	Pressing the BUTTON moves you to the next digit (the ESCAPE key moves you back, if need be). Values from 3 to 24 inches are settable (with stacker system 7 to 17 inches).
	[Save as Setup?]	Here the page length was changed to 12.33 inches.
		In addition this new value can be saved as setup value (using the BUTTON), before the printer is turned ON LINE again.

Note: If the optional **paper stacker system** is used, please adjust the paper stacker to the new page length. (Compare chapter 3 Basic Operation Sequences.)

6.11. Selecting the Number of Printpages per Page Format (Two-Up Mode)

Activating this function determines the arrangement of several printpages per page format (paper width resp. page length).

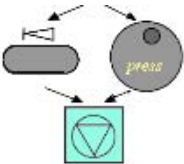
	<u>Panel display</u>	<u>Notes</u>
↓	[SOLID 58E]	Turn the printer OFF LINE with this key.
↓	[Menu Level 1]	
↓	• • •	Turn the BUTTON to the left or right until [Paper Menu] is displayed.
↓	[Paper Menu]	Press the BUTTON to select the paper menu.
↓	[Feeder Select]	
↓	• • •	Turn the BUTTON to the left or right until [Two-Up Mode] is displayed.
↓	[Two-Up Mode]	Press the BUTTON to select the function Two-up mode.
↓	[Y-Direction]	
↓	• • •	Turn the BUTTON to the left or right to effect the adjustment of the two-up mode to the X-direction (cross to the print direction).
↓	[X-Direction]	Press the BUTTON to set the two-up mode.
↓	[X-Direction: OFF]	Turning the BUTTON to the left or right the number of print pages cross to the print direction can be altered. The maximum number of print pages being adjustable next to each other is 9.
↓	• • •	Here the number of print pages per format width was altered to 2.
↓	[X-Direction: 2]	
↓	[press]	
↓	[Save as Setup?]	In addition this new value can be saved as setup value (using the BUTTON), before the printer is turned ON LINE again.
↓		

Example:

The printer SOLID 58E processes fanfold paper with a width of A3. When the Two-Up mode is chosen each time 2 images of A4 are printed side by side.

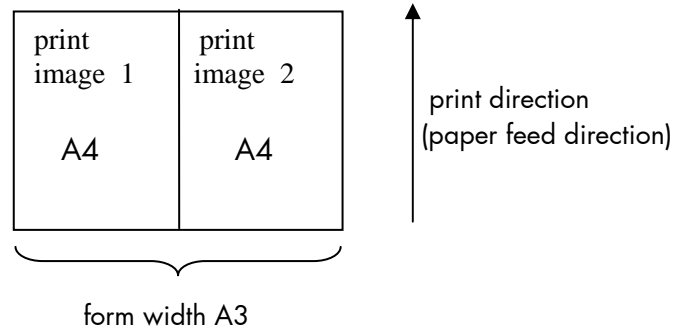

Note:

All other page parameters have to be set optionally in accordance to the requirements.

A simultaneous combination of several print images per form length and several print images per form width isn't possible until now.

6.12. Paper Width Adjusting (Format Width)

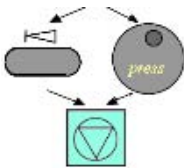
Activating this function adjusts the format width (print width) corresponding to the currently used paper format.

	<u>Panel display</u>	<u>Notes</u>
↓	[SOLID 33E-2]	Turn the printer OFF LINE with this key.
↓	[Menu Level 1]	Turn the BUTTON to the left or right until [Paper Menu] is displayed.
↓	...	
↓	[Paper Menu]	Press the BUTTON to select the paper menu.
↓	[Feeder Select]	Turn the BUTTON to the left or right until [Paper Width] is displayed.
↓	...	
↓	[Paper Width]	Press the BUTTON to adjust the format width to the paper width.
↓	[in Inch]	Inch = currently selected measuring unit (alternative the measuring units mm or dot can be chosen by turning the BUTTON).
↓	...	
↓	[Digit4 08.51]	Turning the BUTTON to the left or right changes the value of the current digit (Digit4 = left digit, in the example: 0). Pressing the BUTTON moves you to the next digit (the ESCAPE key moves you back, if need be).
↓	...	
↓	[Digit1 08.53]	The max. adjustable format width is SOLID 33E-2: 16 inches (17 inches processable), SOLID 58E: 17 inches (18 inches processable). Here the format width was altered to 8.53 inches.
↓	[Save as Setup?]	In addition this new value can be saved as setup value (using the BUTTON), before the printer is turned ON LINE again.
↓		

6.13. Print Direction Selection

This function selects the active print orientation (orientation of the whole printout including graphics, etc. on the paper).

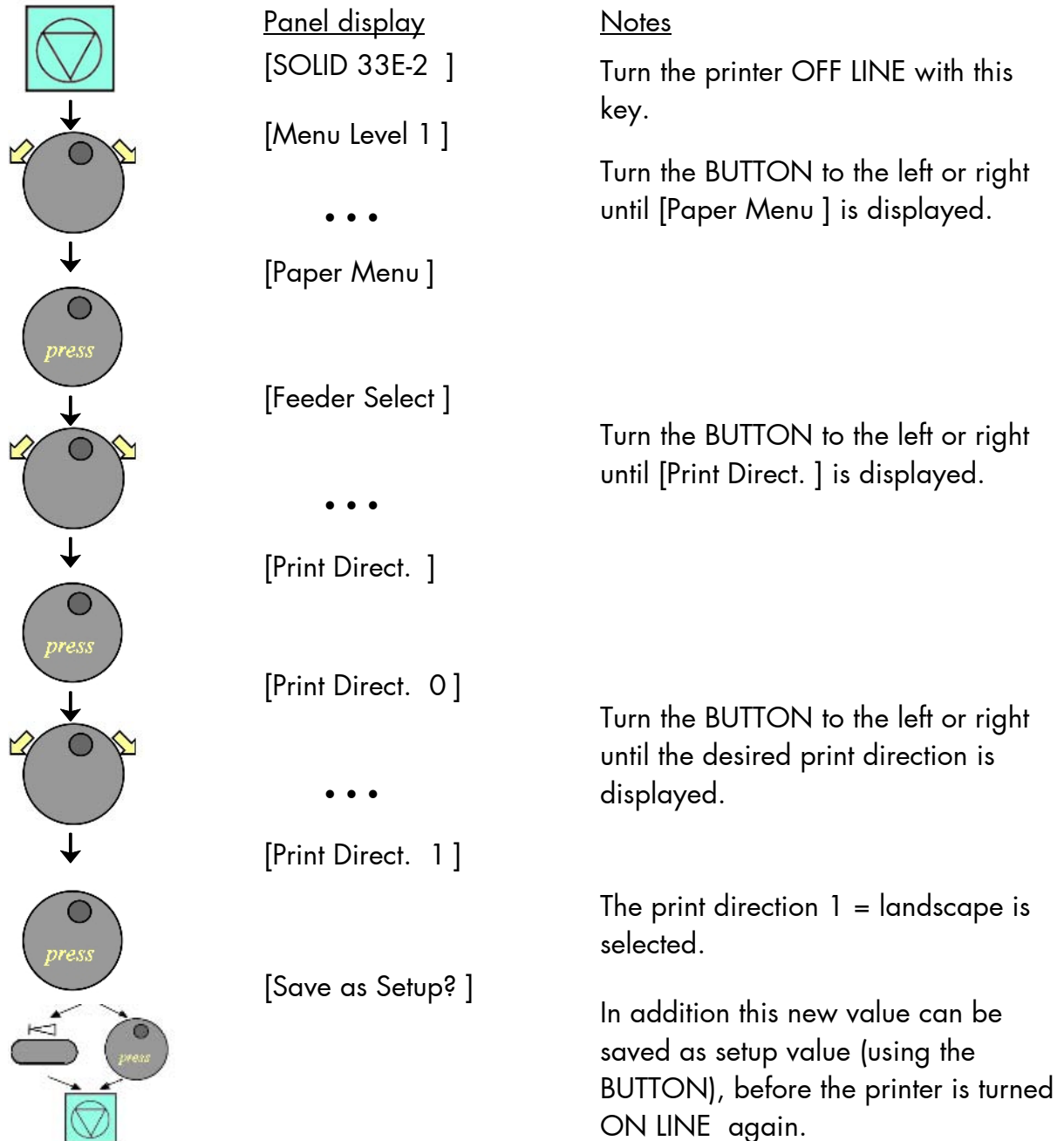

Print direction assignment:

- Print direction 0 = Portrait (upright format)
- Print direction 1 = Landscape (horizontal format)
- Print direction 2 = Portrait upside down
- Print direction 3 = Landscape upside down

6.14. Data Interface Configuration

This function is used to set the interface parameters.

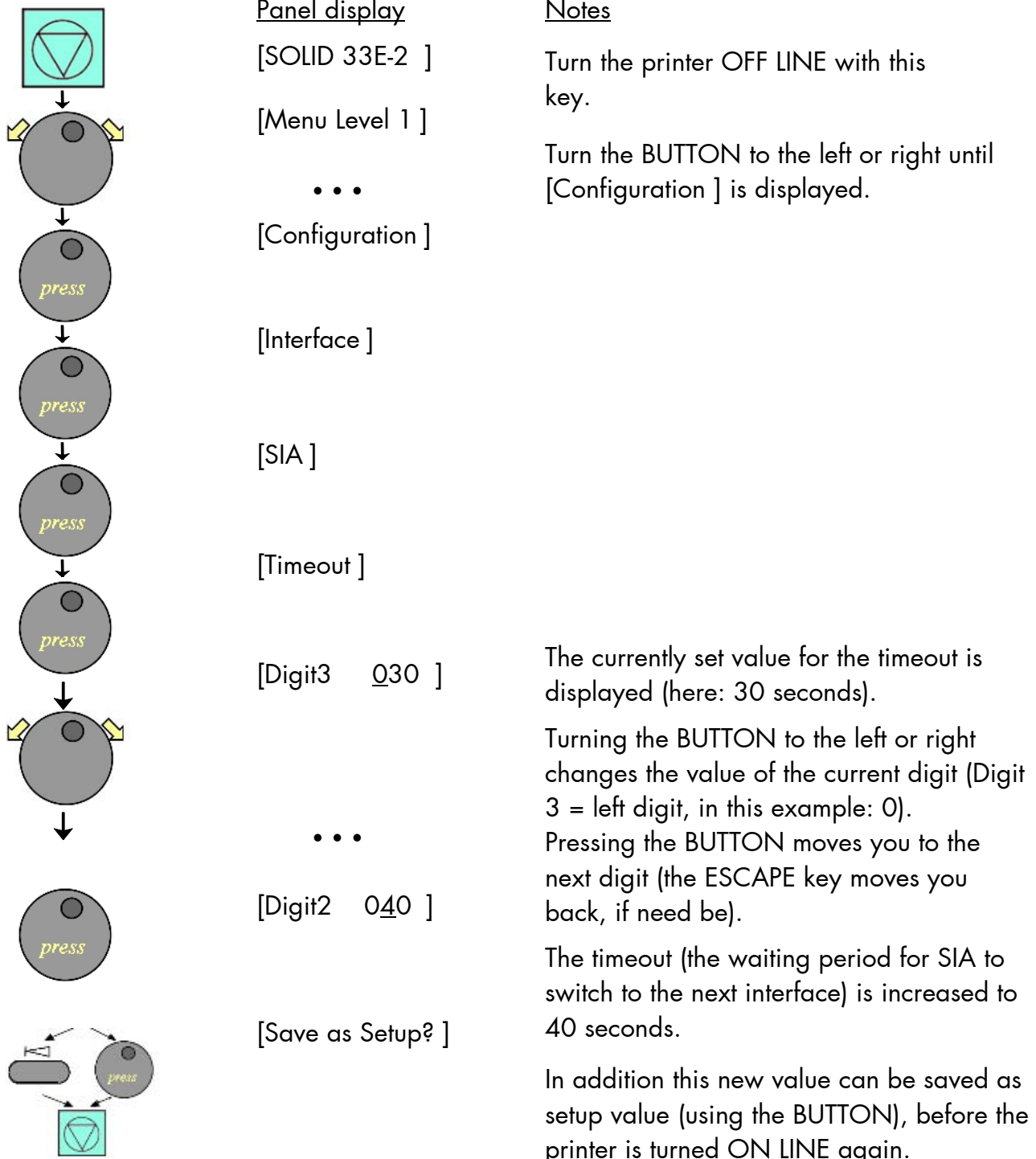







Note:

The printer uses SIA (Simultaneous Interface Administration) to check, which interface is currently used for the transfer of print data.

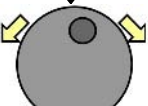
6.15. Emulation Selection

This function helps to determine which printer emulation will be activated.

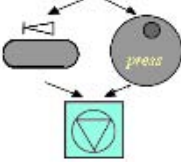
	<u>Panel display</u>	<u>Notes</u>
	[SOLID 33E-2] [Menu Level 1]	Turn the printer OFF LINE with this key.
	...	Turn the BUTTON to the left or right until [Configuration] is displayed.
	[Configuration]	
	[Interface] ...	Turn the BUTTON to the left or right until [Emulation] is displayed.
	[Emulation]	
	[SOLID Standard] ...	Turn the BUTTON to the left or right until the desired emulation (e.g. HP PCL 5) is displayed.
	[HP PCL 5]	The emulation HP PCL 5 is selected.
	[Save as Setup?]	In addition this new value can be saved as setup value (using the BUTTON), before the printer is turned ON LINE again.

Available emulations:

Standard:

MICROPLEX IDOL,
HP LaserJet (PCL 5),
Epson FX,
IBM Proprinter,
TIFF (CCITT group 4),
µPostscript

Optional:







Kyocera Prescribe,
Printronix IGP/PGL,
AGFA Reno,
Diablo 630,
S3000 Lineprinter,
HPGL (7475A),
DEC LN03+,
Tally MT 6xx,
Bull MP6090,
TEC B6xx (Thermal Transfer),
TEC Bx72 (Thermal Transfer),
Etimark (Thermal Transfer),
IDS/IDS2,
Datamax (FGL),
Eltron EPL2,
QMS Magnum Code V,
Tektronix 4010/4014,
XEROX XES,
HP DesignJet (HPGL-2),
LDC (Label Description Language),
Express,
ZPL II (Zebra Programming Language)

Notice:

The brand names mentioned are registered trademarks of the enterprises named above.



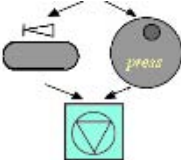

6.16. Display Language Selection

This function enables the user to determine the language for the display messages, the status sheet and the font list.

<u>Panel display</u>	<u>Notes</u>
[SOLID 33E-2]	Turn the printer OFF LINE with this key.
	
[Menu Level 1]	
	Turn the BUTTON to the left or right until [Configuration] is displayed.
...	
[Configuration]	
	
[Interface]	
	Turn the BUTTON to the left or right until [Language] is displayed.
...	
[Language]	
	
[German]	
	Turn the BUTTON to the left or right until the desired language (e.g. English) is displayed.
...	
[English]	
	The display language English is selected.
[Save as Setup?]	In addition this new value can be saved as setup value (using the BUTTON), before the printer is turned ON LINE again.
	



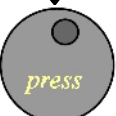
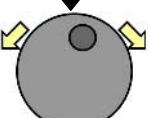
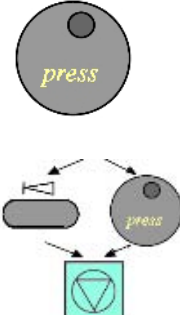

6.17. Transparent Code Adjustment

This function configures the transparent code. Using the transparent code enables you to initiate the commands of the page description language IDOL by **printable** characters. The transparent code pre-setting is 2625. These are the ASCII character codes (hexadecimal) for the characters &%. (ref. IDOL Programming Manual).

	<u>Panel display</u>	<u>Notes</u>
↓	[SOLID 33E-2]	
	[Menu Level 1]	Turn the printer OFF LINE with this key.
↓	• • •	
	[Configuration]	Turn the BUTTON to the left or right until [Configuration] is displayed.
↓	[Interface]	
	• • •	Turn the BUTTON to the left or right until [Transparent Code] is displayed.
↓	[Transparent Code]	
	[Digit4 2625]	The hexadecimal numbers for &% are preset. Turning the BUTTON to the left or right changes the value of the current digit (Digit4 = left position, in this example: 2). Pressing the BUTTON moves you to the next digit (the ESCAPE key moves you back, if need be).
↓	• • •	
	[Digit1 2626]	2626 is selected as transparent code. From now on use the characters && before programming the IDOL commands.
↓	[Save as Setup?]	In addition this new value can be saved as setup value (using the BUTTON), before the printer is turned ON LINE again.
		

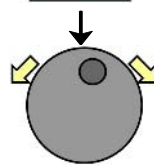

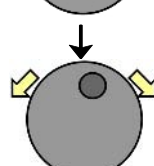

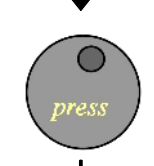
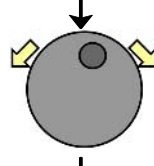
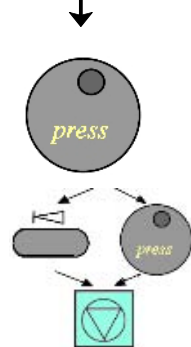
6.18. Selection of Memory Distribution (Input Buffer)

This function enables the user to choose the distribution of the available RAM memory between input buffer and macro/download memory.

	<u>Panel display</u>	<u>Notes</u>
	[SOLID 33E-2]	Turn the printer OFF LINE with this key.
	[Menu Level 1]	Turn the BUTTON to the left or right until [Configuration] is displayed.
	[Configuration]	
	[Interface]	Turn the BUTTON to the left or right until [Input Buffer] is displayed.
	[Input Buffer]	
	[32 kB]	Turn the BUTTON to the left or right until the desired memory distribution is displayed. The input buffer size is specified in kilobyte (kB) or in percent of the installed memory.
	[100 kB]	100 kB is selected as input buffer.
	[Save as Setup?]	In addition this new value can be saved as setup value (using the BUTTON), before the printer is turned ON LINE again.
		

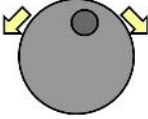

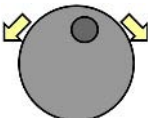

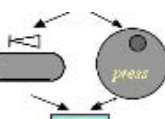
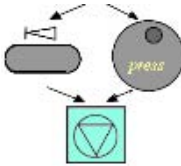
6.19. Setting to Factory Default

This function back-outs all configurations to factory defaults.

	<u>Panel display</u>	<u>Notes</u>
	[SOLID 33E-2]	Turn the printer OFF LINE with this key.
	[Menu Level 1]	Turn the BUTTON to the left or right until [Configuration] is displayed.
	...	
	[Configuration]	
	[Interface]	Turn the BUTTON to the left or right until [Factory Default] is displayed.
	...	
	[Factory Default]	
	[Save as Setup?]	Only if you press the BUTTON a second time the configuration is back-outed to factory defaults.
		The printer is turned ON LINE again.

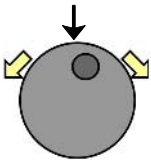
6.20. Font Selection

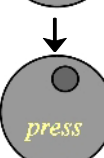
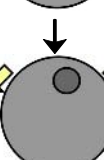
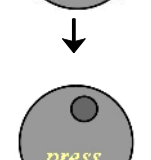
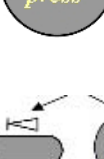
This function selects the active font. Select a font number out of the list of available fonts.

<u>Panel display</u>	<u>Notes</u>
	[SOLID 33E-2]
	[Menu Level 1]
	...
	[Page Menu]
	[Font Number]
	[Font 0600]
	...
	[Font 5507]
	[Save as Setup?]
	Turn the printer OFF LINE with this key.
	Turn the BUTTON to the left or right until [Page Menu] is displayed.
	Turn the BUTTON to the left or right until the desired font number (e.g. 5507 Langeoog) is displayed.
	The font number 5507 Langeoog is selected.
	In addition this new value can be saved as setup value (using the BUTTON), before the printer is turned ON LINE again.

The **SOLID 33E-2 and SOLID 58E standard equipment** contains the following **fonts**:

<u>Font no.</u>	<u>Font width</u>	<u>Font height</u>	<u>Font name</u>
0600	10	12	Kurilen
0602	10	12	Kurilen Italic
0610	12	10.1	Kurilen
1710	12	10.1	Kurilen Italic
4508	P	8.1	Helgoland
4510	P	10	Helgoland
4714	P	14.4	Helgoland Bold
5507	20	7	Langeoog
5508	16.6	7.9	Langeoog
5509	15	9.1	Langeoog
6610	10	10.1	Juist Monosp.
9210	P	10.1	Tasmanien
9310	P	10.1	Tasmanien Italic
2000	P	SC	Tasmanien
9900	P	SC	Neuwerk

Resumption of this standard font list see next page.

Explanations:

Font width:

Character distance in CPI (Characters Per Inch).

P = proportional, (meaning that each character has an individual width).

Font height:

Font height from the lowest descender to the upper edge of the highest character, measured in graphical points (1/72 inch).

SC = scalable.

	<u>Font no.</u>	<u>Font width</u>	<u>Font height</u>	<u>Font name</u>
	0050	SC		Plakatschrift
	0590	SC		OCR /B
	0591	SC		OCR /A
	6600	SC		Juist Monospaced
PCL 5 compatible	0699	SC		Kurilen
	1700	SC		Kurilen Italic
	1800	SC		Kurilen Bold
	1900	SC		Kurilen Bold Italic
	5500	SC		Langeoog
	5600	SC		Langeoog Bold
	5700	SC		Langeoog Italic
	5800	SC		Langeoog Bold Italic
	2100	P	SC	Texel Bold
	2200	P	SC	Texel Italic
	2300	P	SC	Texel Bold Italic
	9800	P	SC	Neuwerk Italic
	9500	P	SC	Neuwerk Bold Italic
	9600	P	SC	Neuwerk Bold
	0060	SC		Plakatschrift
	9501	P	SC	Neuwerk-II Condensed Italic
	9601	P	SC	Neuwerk-II Condensed Bold Ital.
	9801	P	SC	Neuwerk-II Condensed Bold
	9901	P	SC	Neuwerk-II Condensed
	0530	P	SC	PiktoWin
	5100	P	SC	Amrum
	5200	P	SC	Amrum Bold
	5300	P	SC	Amrum Italic
	7500	P	SC	Antigua
	7700	P	SC	Antigua Bold
	7800	P	SC	Antigua Italic
	7900	P	SC	Antigua Bold Italic
	9199	P	SC	Tasmanien-II Bold Italic
	9299	P	SC	Tasmanien-II
	9399	P	SC	Tasmanien-II Italic
	9499	P	SC	Tasmanien-II Bold

Notes: Additional fonts can be selected from the font catalogue depending upon the memory capacity.

You can use the panel function Printing the Font List (see section 6.2) to generate a list of all fonts installed to the printer.

6.21. Text Orientation Selection

This function selects the active text orientation.

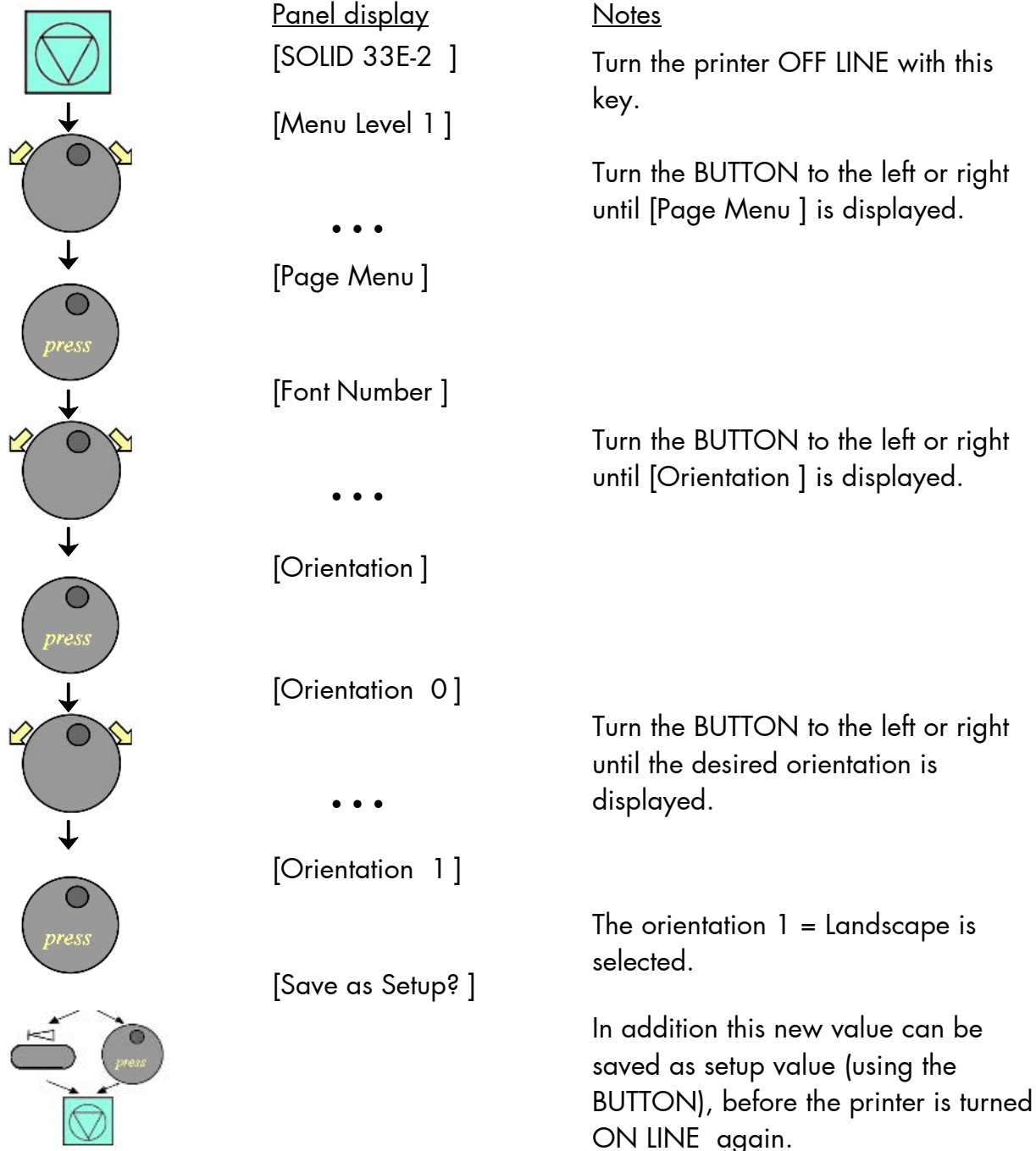











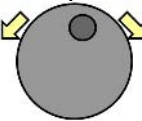



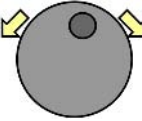

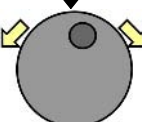

Text orientation assignment:

- Orientation 0 = Portrait (upright format)
- Orientation 1 = Landscape (horizontal format)
- Orientation 2 = Portrait upside down
- Orientation 3 = Landscape upside down

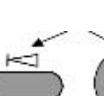
6.22. Symbol Code Selection

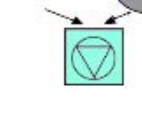
This function selects the active symbol code.

	<u>Panel display</u>	<u>Notes</u>
	[SOLID 33E-2]	Turn the printer OFF LINE with this key.
 	[Menu Level 1] ...	Turn the BUTTON to the left or right until [Page Menu] is displayed.
 	[Page Menu]	
 	[Font Number] ...	Turn the BUTTON to the left or right until [Symbol Code] is displayed.
 	[Symbol Code]	
 	[902, IBM PC-II] ...	Turn the BUTTON to the left or right until the desired symbol code is displayed.
 	[901, IBM PC-I]	The symbol code 901, IBM PC-I is selected.
      	[Save as Setup?]	In addition this new value can be saved as setup value (using the BUTTON), before the printer is turned ON LINE again.



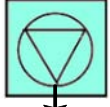
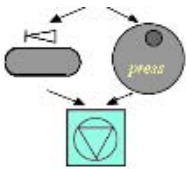

6.23. Configuration of Text Margins

This function sets text margins. Margins are expressed in dots at the concerning edge of the paper.

	<u>Panel display</u>	<u>Notes</u>
↓	[SOLID 33E-2]	Turn the printer OFF LINE with this key.
↓	[Menu Level 1]	
↓	• • •	Turn the BUTTON to the left or right until [Page Menu] is displayed.
↓	[Page Menu]	
↓	<i>press</i>	
↓	[Font Number]	
↓	• • •	Turn the BUTTON to the left or right until [Margin] is displayed.
↓	[Margin]	
↓	<i>press</i>	
↓	[Left]	
↓	• • •	Turn the BUTTON to the left or right until the desired margin is displayed.
↓	[from Right]	
↓	<i>press</i>	
↓	[Digit4 0089]	Turning the BUTTON to the left or right changes the value of the current digit (digit 4 = left position, in this example: 0). Pressing the BUTTON moves you to the next digit (the ESCAPE key moves you back, if need be).
↓	• • •	
↓	[Digit1 008Z]	
↓	<i>press</i>	The right margin is changed into 87 dot.
↓	[Save as Setup?]	In addition this new value can be saved as setup value (using the BUTTON), before the printer is turned ON LINE again.
		

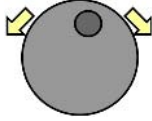
6.24. Image Shifting to the X-Direction

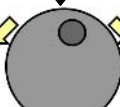
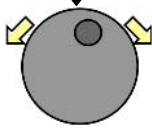
This function shifts the print image in relation to the paper to the X-direction (crosswise the print direction). Because the paper feed is always centered to the middle (SOLID 33E-2 and SOLID 58E), the image shifting might be necessary when using e.g. special paper formats to shift the X-coordinate zero to the left paper edge.

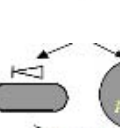
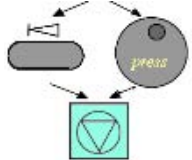
<u>Panel display</u>	<u>Notes</u>
	[SOLID 33E-2] Turn the printer OFF LINE with this key.
	[Menu Level 1] Turn the BUTTON to the left or right until [Engine] is displayed.
...	
	[Engine]
	[Image X-Pos.] The panel function Image Shifting to the X-Direction is selected.
	[Image X-Pos: +0 Dot] Currently set value (0 = Default).
	Turning the BUTTON to the left or right the value for the image shift can be altered. Values from -288 up to +288 Dot are settable, so a max. image shifting of appr. ±1 Inch (approx. ±25 mm) can be reached.
...	
	Image X-Pos: +50 Dot] Now the new image X-Position is saved.
	[Save as Setup?] In addition this new value can be saved as setup value (using the BUTTON), before the printer is turned ON LINE again.
	

Example for shifting the image to the X-direction:

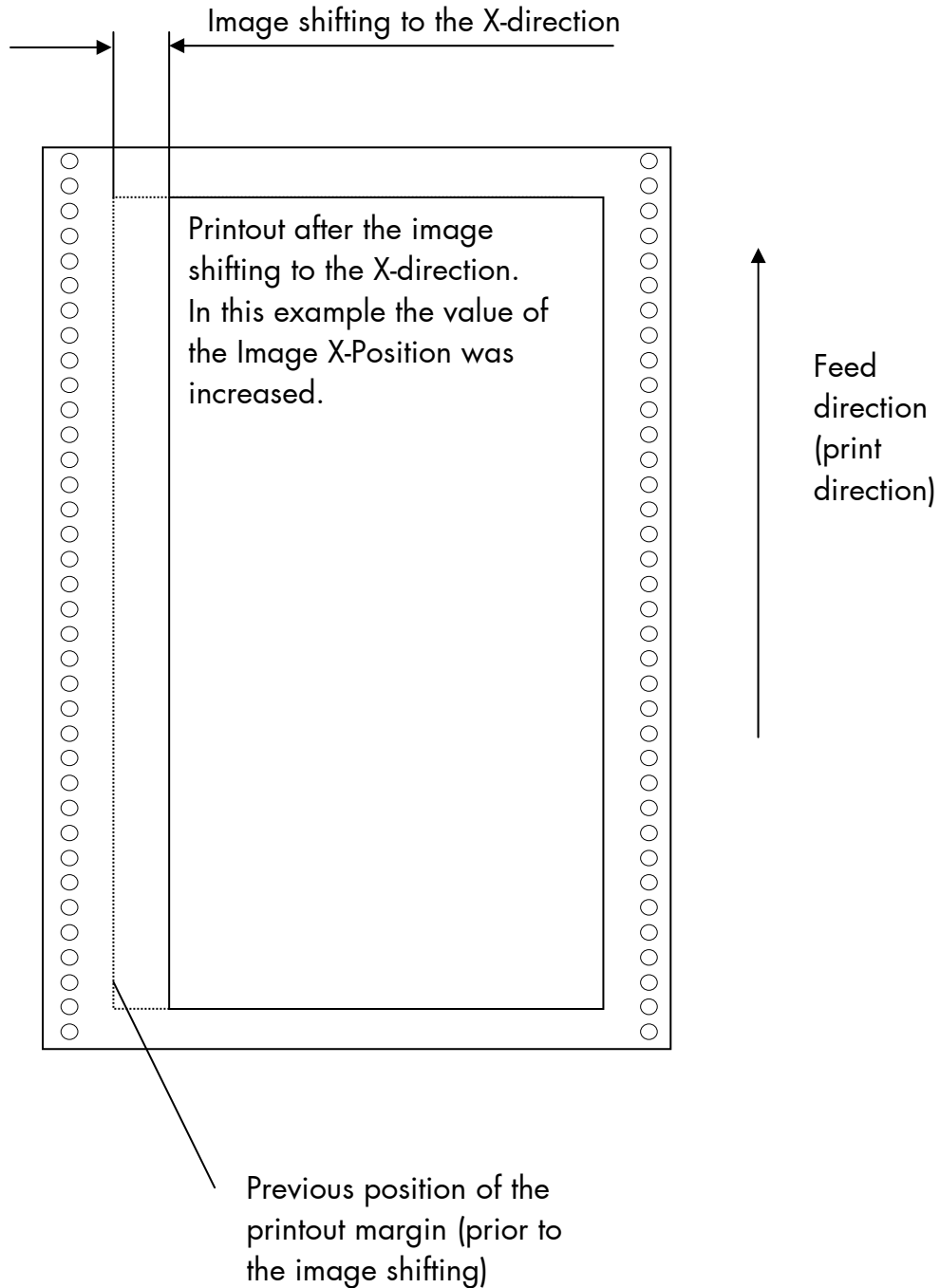

6.25. Image Shifting to the Y-Direction

This function shifts the print image in relation to the paper to the Y-direction (print direction).

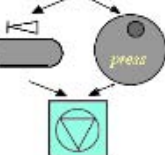
	<u>Panel display</u>	<u>Notes</u>
↓	[SOLID 33E-2]	Turn the printer OFF LINE with this key.
↓	[Menu Level 1]	
↓	• • •	Turn the BUTTON to the left or right until [Engine] is displayed.
↓	[Engine]	
↓	[Image X-Pos.]	
↓	• • •	Turn the BUTTON to the left or right until [Image Y-Pos.] is displayed.
↓	[Image Y-Pos.]	
↓	[Image Y-Pos: +0 Dot]	Currently set value (0 = Default).
↓	• • •	Turning the BUTTON to the left or right the value for the image shift can be altered. Values from -152 up to +148 Dot are settable, so a max. image shifting of appr. ± 0.6 Inch (appr. ± 15 mm) can be reached.
↓	[Image Y-Pos: +65 Dot]	Now the new image Y-Position is saved.
↓	[Save as Setup?]	In addition this new value can be saved as setup value (using the BUTTON), before the printer is turned ON LINE again.
↓		

Example for shifting the image to the Y-direction:

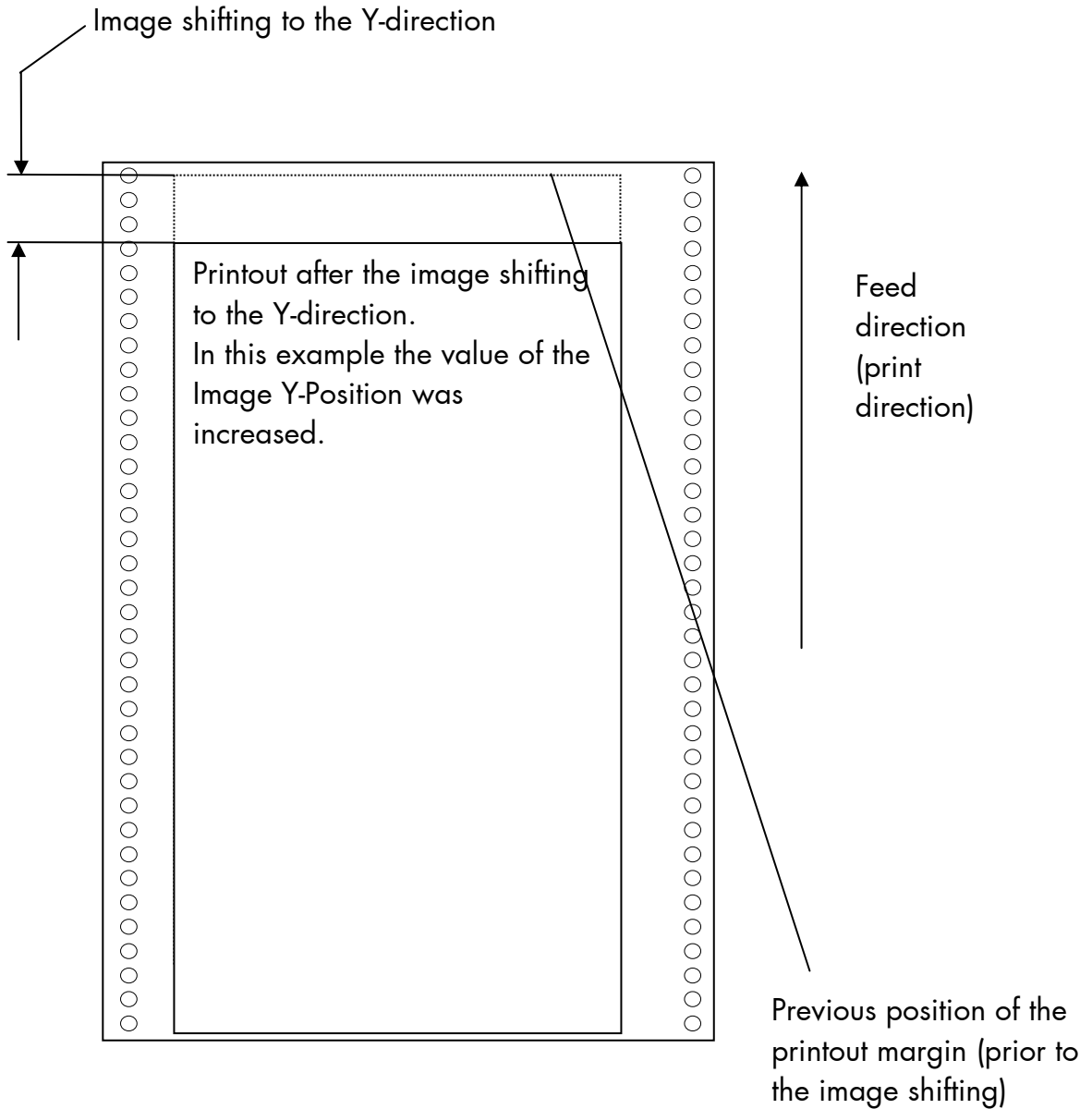

6.26. Adjusting the Cutting Position

This function is used to carry out a fine adjustment of the cutting edges position on the material to be printed on.







Note: The adjustment is corresponding to the adjusted page length (see section 6.10).

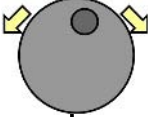

If, for some reason, it is not desired to cut exactly on the perforation it is very important to cut below the perforation.

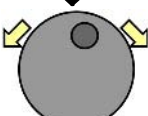
If the paper is cut above the perforation the remaining paper can easily bend and cause a paper jam.

Do not cut through a label as the blade would get dirty by the glue.

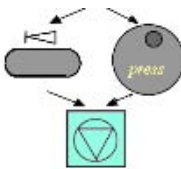
	Panel display	Notes
↓	[SOLID 33E-2]	Turn the printer OFF LINE with this key.
	[Menu Level 1]	Turn the BUTTON to the left or right until [Engine] is displayed.
↓	...	
↓	[Engine]	
	[Image X-Pos.]	Turn the BUTTON to the left or right until [Cutting Menu] is displayed.
↓	...	
↓	[Cutting Menu]	
	[Autom.Cutting]	Turn the BUTTON to the left or right until [Cutting Pos.] is displayed.
↓	...	
↓	[Cutting Pos.]	
	[Cutting Pos: + 0 Dot]	0 Dot = currently set value.
↓	...	Turn the BUTTON to the left or right until the desired value for the cutting position is displayed. Values from -152 to +148 dot are adjustable.
↓	[Cutting Pos: + 30 Dot]	The new cutting position is shifted by +30 Dot = 0.1 inch opposite to the print direction.
	[Save as Setup?]	In addition this new value can be saved as setup value (using the BUTTON), before the printer is turned ON LINE again.
↓		
		

6.27. Cutting Mode Selection

This function selects the printer's cutting mode. The "Automatic Cutting" mode means each sheet is cut automatically after printing.

Note: When using the upper stacker of the SOLID 33E-2 (see section 6.9: Stacker Selection) every sheet is cut off (independent of the selected cutting mode).

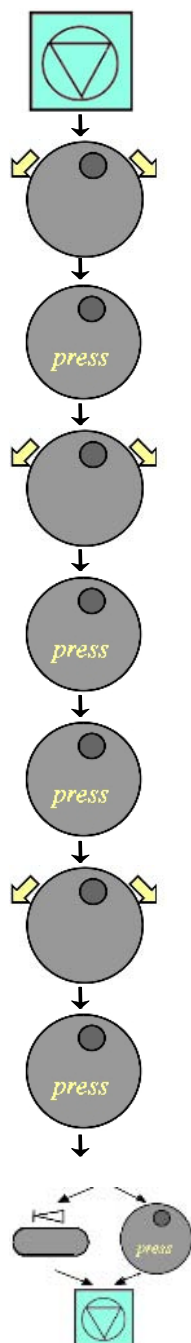

Panel display

Notes

[SOLID 33E-2]

Turn the printer OFF LINE with this key.

[Menu Level 1]

Turn the BUTTON to the left or right until [Engine] is displayed.

• • •

[Engine]

[Image X-Pos.]

Turn the BUTTON to the left or right until [Cutting Menu] is displayed.

• • •

[Cutting Menu]

[Autom.Cutting]

[Off]

Turn the BUTTON to the left or right until the desired mode (e.g. automatic cutting on) is displayed.

• • •

[On]

Automatic cutting is selected.

[Save as Setup?]

In addition this new value can be saved as setup value (using the BUTTON), before the printer is turned ON LINE again.

Assignment of the cutting modes:

- Automatic Cutting Off = After printing there is no cutting of the material.
(Continuous)
- Automatic Cutting On = During the print process a cut off is performed
automatically after each sheet.

Note: After each print job there is an additional material feed to transport the printed material to the fusing station (and cutter). The printer conveys the media back automatically (Retract). After this the unprinted material inside the printer has reached the so-called "TOP OF FORM" position, again.





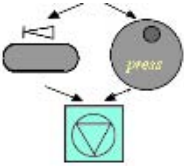

6.28. Standby Time Adjustment

This function is used to stipulate the period the printer waits after every print job before going into the standby mode (then the temperature of the fusing station will be reduced).

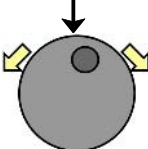
	<u>Panel display</u>	<u>Notes</u>
↓	[SOLID 33E-2]	Turn the printer OFF LINE with this key.
↓	[Menu Level 1]	Turn the BUTTON to the left or right until [Engine] is displayed.
↓	• • •	
↓	[Engine]	
↓	[Image X-Pos.]	
↓	• • •	Turn the BUTTON to the left or right until [Standby Time] is displayed.
↓	[Standby Time]	
↓	[Standby Time: Always]	Currently set value: Always = there is never a switch-over to the standby mode.
↓	• • •	Turn the BUTTON to the left or right to change the standby time (periods from 4 up to 900 seconds are adjustable).
↓	[Standby Time: 80 s]	
↓	[Standby Time: 80 s]	The period until switching over to the standby mode is set to 80 s.
↓	[Save as Setup?]	In addition this new value can be saved as setup value (using the BUTTON), before the printer is turned ON LINE again.
↓		

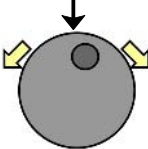
6.29. Power Save Time Adjustment

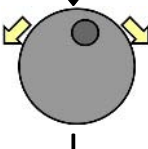

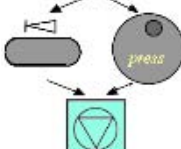
This function is used to stipulate the period the printer waits after the standby time (see previous section) before switching to the power save mode (power reduction).

<u>Panel display</u>	<u>Notes</u>
	Turn the printer OFF LINE with this key.
	Turn the BUTTON to the left or right until [Engine] is displayed.
[SOLID 33E-2]	
[Menu Level 1]	
...	
	
[Engine]	
	Turn the BUTTON to the left or right until [Pow. Sav.Time] is displayed.
[Image X-Pos.]	
...	
	
[Pow. Sav.Time]	
	Currently set value: Off = there is never a switch-over to the power save mode.
[Off]	
...	Turn the BUTTON to the left or right to change the power save time (periods from 1 to 60 min can be adjusted).
	
[40 min]	The period until switching over to the power save mode is set to 40 min.
	In addition this new value can be saved as setup value (using the BUTTON), before the printer is turned ON LINE again.
[Save as Setup?]	

6.31. Configuration of Network Parameters (IP Address e.g.)

The functions of the submenu Network are used to set the parameters for connecting the printer to a network (Ethernet).

Setting the IP address manually:

<u>Panel display</u>	<u>Notes</u>
	
[SOLID 33E-2]	Turn the printer OFF LINE with this key.
[Menu Level 1]	Turn the BUTTON to the left or right until [Network] is displayed.
...	
[Network]	Press the BUTTON to select the Network menu.
[Timeout]	Turn the BUTTON to the left or right until [IP Assign] is displayed.
...	
[IP Assign]	Press the BUTTON to select the IP Assign menu.
[Off]	The currently set configuration is displayed.
...	Turn the BUTTON to the left or right until [Manual] is displayed.
[Manual]	
[press]	
[IP Address]	Press the BUTTON to set the IP address manually.
[192.168.002.002]	Turning the BUTTON to the left or right changes the value of the current position (left digit first, in this example: 1).
...	Pressing the BUTTON moves you to the next position (the ESCAPE key moves you back, if need be).
[192.168.010.123]	
[press]	The new IP address is saved as setup value.
[Saved !]	
	The printer is turned ON LINE again.

Notes: If your network is using DHCP^①, an address can be automatically assigned (select the item **DHCP** from the network submenu IP Assign).

The parameters **Subnet Mask** and **Gateway** are configured in the same way as described above. Please select the concerning panel functions for this (compare section 5.6 Menu Structure).

Select the subitem **Off** from the network menu to switch off the network access.

^① Dynamic Host Configuration Protocol: offers among other things a centralized address management.

Duplex/Speed Setting

This panel function is located in the network menu (submenu Duplex/Speed Setting).

The factory default value is Autonegotiation.

Autonegotiation means that devices on the network agree a transmission mode, which each unit is able to handle, before data transmission starts. By this the printer automatically adjusts itself to maximize link performance.

Hint: Autonegotiation is the recommended setting!

If you set the Duplex/Speed parameters manually, you may experience problems. Wrong settings can slow down the speed of the link (worst case: communication does not occur).

Explanations:

Auto-Negotiation

A Ethernet procedure that allows devices at either end of a link segment to advertise and negotiate modes of operation such as the speed of the link (100 Mbit/s or 10 Mbit/s) and half- or full-duplex operation.

Half duplex

A device can either receive or send data at a given time.

Full duplex

Capability of a device for sending and receiving data at the same time. In the case of full duplex, collision detection is deactivated. A full duplex capable device is able to buffer data packets.

7. Operator Maintenance

In order to run the printer always on its highest quality level, it is necessary to perform regularly simple cleaning operations, and to occasionally replace certain components.

These operations can be performed by a MICROPLEX trained operator. A untrained person is not allowed to perform these operations.

7.1. Printer Cleaning

By a regular and conscientious performance of the following operations, the printer is guaranteed to always work at an optimum reliability.



For safety pull out the mains plug first. Make sure the components that are to be cleaned have cooled down.



Please be especially careful to avoid damaging mechanical or electronic modules.

Do not use detergents, or any other devices or tools not mentioned in this manual to avoid damages and unnecessary costs of repairs. Please do only use the auxiliary materials being contained inside the cleaning kit.

The regular cleaning interval is 50,000 pages.

7.1.1. Cleaning the Printer Cabinet

- Please use a soft, lint-free cloth, which has been moistured with water or a neutral detergent if necessary to remove dust and grease from the printer cabinet.

- Please be especially careful to avoid damaging the mechanical or electronic components.

7.1.2. Cleaning the Printer Interior



Turn off the printer and pull the power plug. Make sure, the printer has been switched off for at least 15 minutes before you start cleaning.

Please be especially careful to avoid damaging the mechanical or electronic modules.

The user shall clean the paper path inclusive the tractor cassettes and the transfer charge unit from paper dust resp. toner dust in regular intervals of about 50,000 pages. The interval may vary dependent on the paper in use.

It is strongly recommended to use a vacuum cleaner which is suitable for paper dust and toner dust as well. Printing on recycled paper may further require cleaning of the ozone filter which is located underneath the transfer charger, in order to ensure low level ozone emission.

The following cleaning operations should always be performed before the installation of a new toner cartridge (see also section 7.2 Replacing the Toner Cartridge).



If there are any toner residues on the print pages, please do also perform a cleaning of the printer interior.

If the problem cannot be solved by this, please replace additionally the cleaner felt (see section 7.4 Replacing the Cleaner Felt).



1. Disconnect the printer from the mains and let it cool down for at least 15 minutes.

2. Remove all toner residues, paper dust etc. in the area of the paper feeder (tractor) and the paper outlet with an anti-static service vacuum cleaner.

3. Open the printer's front cover (incl. the control panel).

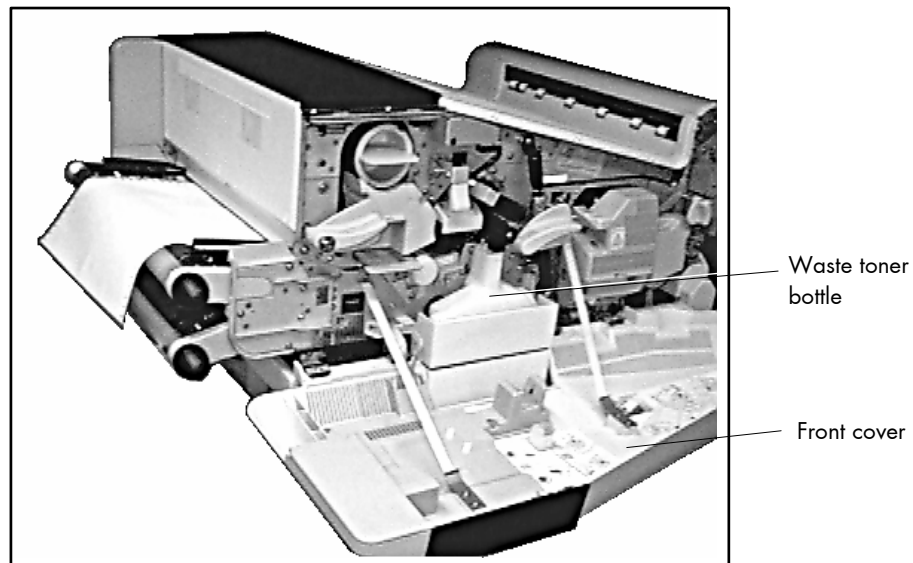

Fig. 7.1.2.a Printer opened

4. Remove the toner residues from the environment of the waste toner bottle with an anti-static service vacuum cleaner (see section 7.3).
5. Rotate the lever counterclockwise to unlock the developer unit.



Fig. 7.1.2.b Detail: Unlocking the developer unit

6. Pull the developer unit about 2/3 out of the housing.

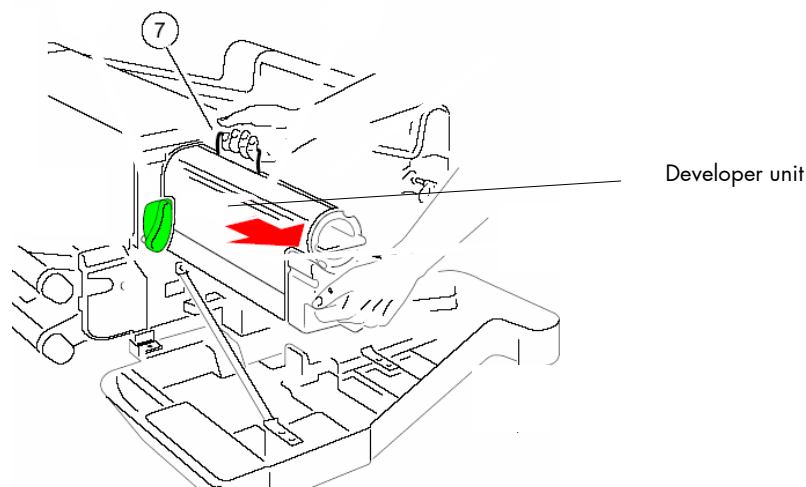

Fig. 7.1.2.c Taking out the developer unit

7. Grasp the grip (7) with the other hand and remove the developer unit from the printer.
8. Please clean carefully the components in the printer interior being in reach now with the help of an anti-static vacuum cleaner and a clean pulp-free cloth.



Please don't touch the OPC drum and be very careful to protect the OPC drum during the cleaning operations.

9. Now take the developer unit and position it in front of the corresponding opening of the printer.
10. Slide the developer unit back into the printer. (Compare figure 7.1.2.c)
11. Slowly push the developer unit into the printer until it stops.
12. Secure the developer unit by rotating the lever clockwise. (Compare figure 7.1.2.b)

13. Open the printer's rear cover.

14. Press the lever (see the following figure) to open the printer's top cover.

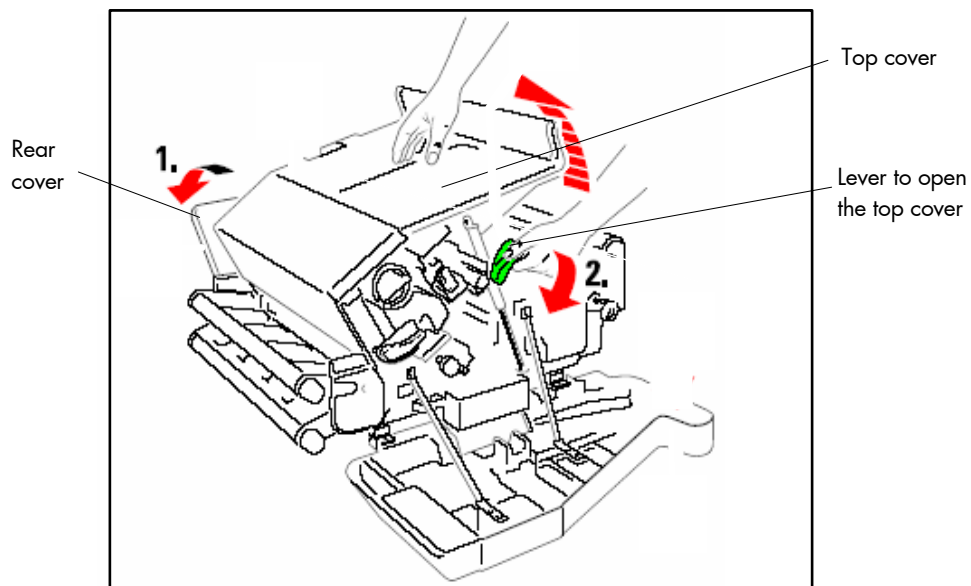

Fig. 7.1.2.d Opening the rear and top cover

15. Press the lever (see the following figure) to open the printer's paper exit area.

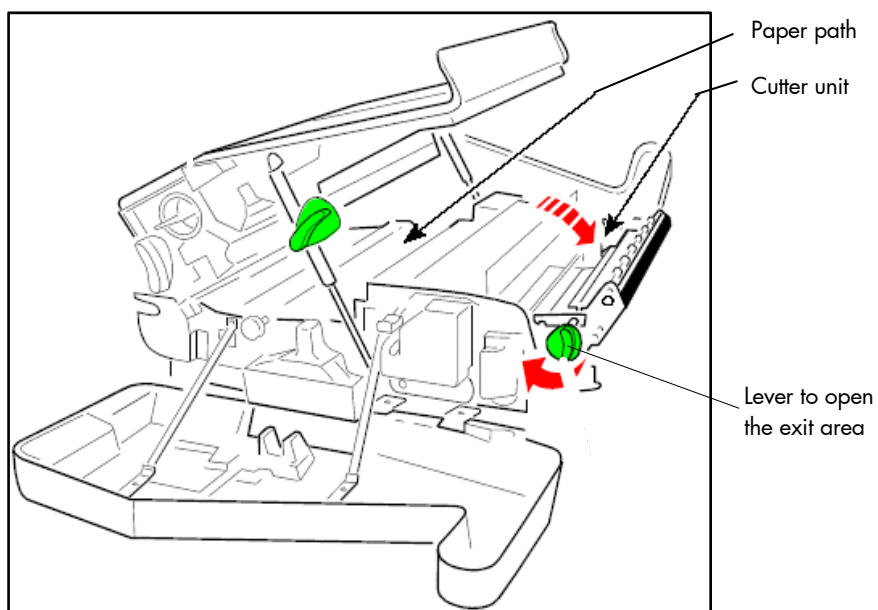

Fig. 7.1.2.e Opening the paper exit area

16. Clean the paper path inclusive the tractor cassettes using an anti-static service vacuum cleaner.
17. Clean the transfer charge unit from paper dust and toner dust.
18. Clean the area of the fuser unit and check the cleaner felt.

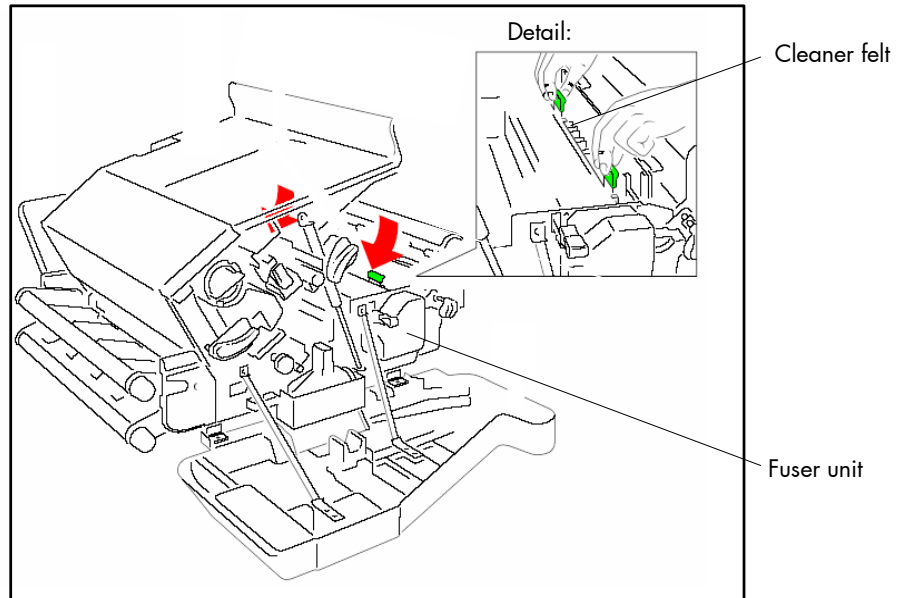

Fig. 7.1.2.f Checking the cleaner felt

Note: Depending on paper properties it may be necessary to change the cleaner felt more often than with every second toner cartridge.

19. Close the printer's top cover.
20. Close the printer's rear cover.
21. Close the printer's front cover.

7.2. Replacing the Toner Cartridge



The message [Toner Low] is only a warning that the printer will run out of toner soon; but don't replace the toner cartridge! Replace the toner cartridge as soon as the message [Toner empty !] is displayed. In average about 14,000 pages (15 inches x 11 inches) can be printed with one toner cartridge filling (depending on the print density; here a density of 5% was based). One toner kit contains 10 toner cartridges.



Only use consumables that have been approved for use with this device.
To avoid soiling your hands please wear protective gloves during this operation. Take care not to spill any toner inside the printer.

a) Removing the old toner cartridge

1. Prepare a place to put the spent toner cartridge. For example, you might put it in a small plastic trash bag or on sheets of paper. The spent toner cartridge will give off black toner dust.
2. Turn the printer OFF LINE.
3. Open the printer's front cover (incl. the control panel).

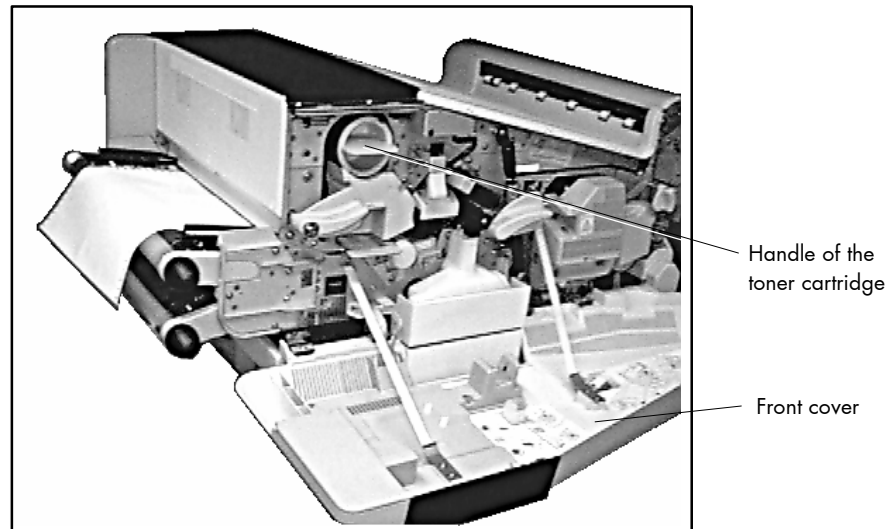

Fig. 7.2.a Printer's front cover open

4. Use the handle (see figure 7.2.a) to rotate the old toner cartridge 180° clockwise until it touches.
5. Slowly pull the used toner cartridge out of the printer (see fig. 7.2.b) and put it in the place you prepared for it.

Please use your second hand to hold the cartridge.

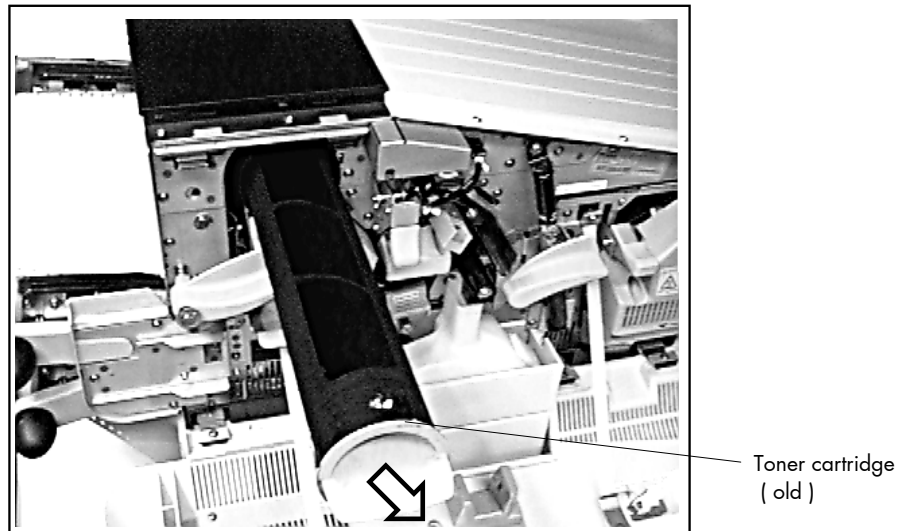

Fig. 7.2.b Removing the used toner cartridge

6. Wrap up the used toner cartridge so it doesn't spill toner dust. Lead the old toner cartridge to a duly disposal.

b) Performing a cleaning of the printer interior

The description can be found in section 7.1.

c) Inserting the new toner cartridge

7. Take the new toner cartridge out of the packing and hold it as shown in figure 7.2.c (plastic sealing tape point upward).
8. Shake the new toner cartridge gently by performing horizontal movements to distribute the toner.

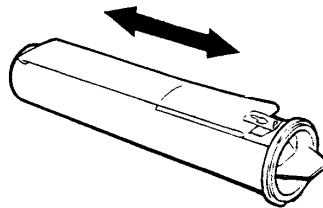

Fig. 7.2.c Shaking the new toner cartridge

9. Now take the new toner cartridge and position it in front of the corresponding opening of the printer.
10. Insert the new toner cartridge approximate 10 cm into the printer, illustrated below, with the attached plastic seal (adhesive tape) pointing to the top.

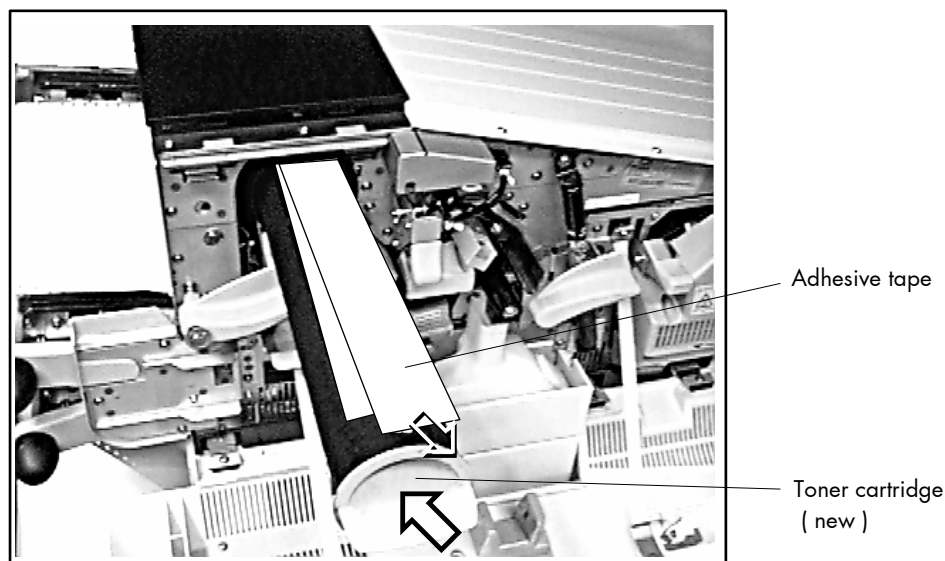

Fig. 7.2.d New toner cartridge inserting

11. Slide the toner cartridge slowly into the device and pull off the plastic seal (adhesive tape) at the same time (see arrows in figure 7.2.d).

Hint: Roll or fold the sealing strip as you pull. This avoids snapping the sealing strip when it reaches the end of the toner cartridge and scattering any loose toner on the sealing strip.

12. Remove the adhesive tape completely and dispose of it in the trash.
13. Slowly push the toner cartridge into the developer unit until it stops.

d) Dropping toner into the developer unit

14. Now rotate the toner cartridge slowly about 180° counterclockwise (until it touches; compare fig. 7.2.e).



The cap of the toner cartridge must be located behind the "nose" (before the turning of the toner cartridge the "notch" in the cap enables the passing of the "nose").

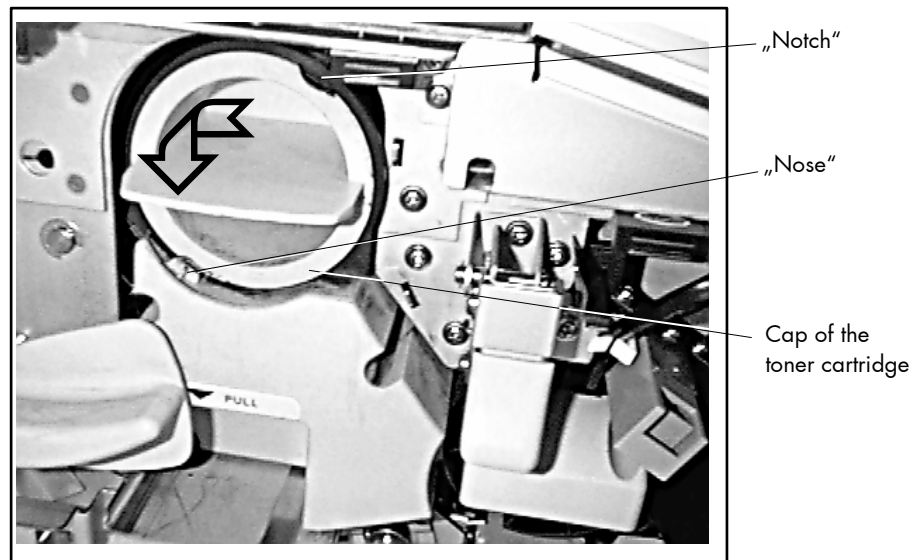

Fig. 7.2.e Locking the toner cartridge

The rotation of the toner cartridge effects that the toner falls out of the toner cartridge into the developer unit.

Now the toner cartridge's handle should be horizontal and the toner cartridge is locked into position.

15. Close the printer's front cover.

16. Press the ON LINE key.

The message [Toner Empty !] in the control panel display is extinguished.



Toner is easily combustible and must not come in contact with fire. Disposal is carried out by your service engineer. Until then keep the old toner cartridge inside a closed cardboard box.



Now check the waste toner bottle (see next section).

Check if the cleaner felt and ozone filter has to be replaced, too. (See section 7.4 and section 7.5).

7.3. Exchanging the Waste Toner Bottle

The waste toner bottle has to be replaced with every second toner cartridge (compare section 7.2). Exchange the waste toner bottle immediately, if the message [Toner Waste!] is displayed.

In average about 28,000 pages (15 inches x 11 inches) can be printed until the waste toner bottle is filled (depending on the print density; here a density of 5% was based).

One toner kit contains 5 waste toner bottles.

1. Turn the printer OFF LINE.
2. Open the printer's front cover.
3. Open the printer's rear cover.
4. Press the lever (see the following figure) to open the printer's top cover.

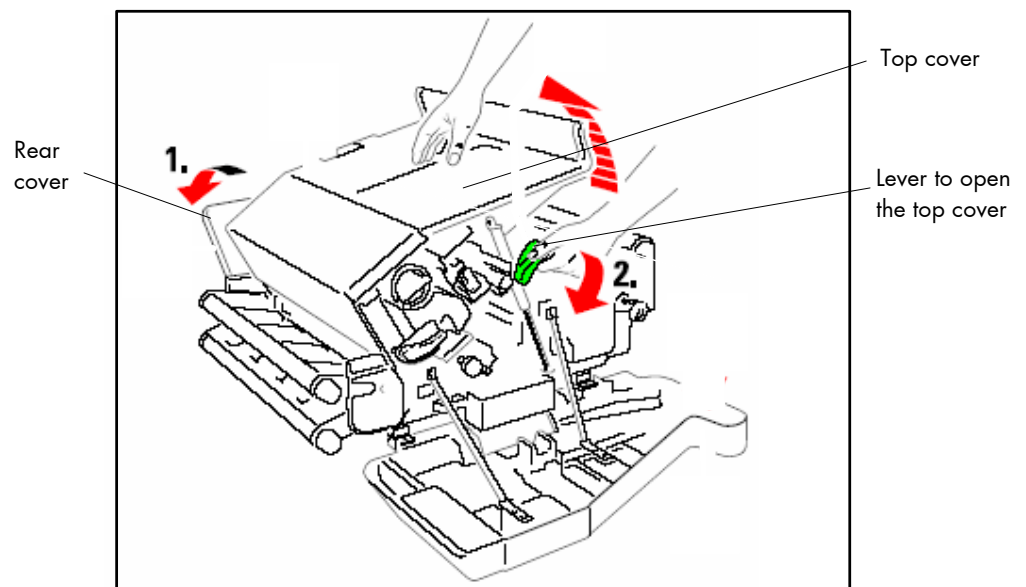

Fig. 7.3.a Opening the rear and top cover

5. Remove the old waste toner bottle from the printer using both of your hands.



Please be careful to avoid a leaking of toner powder from the bottle.

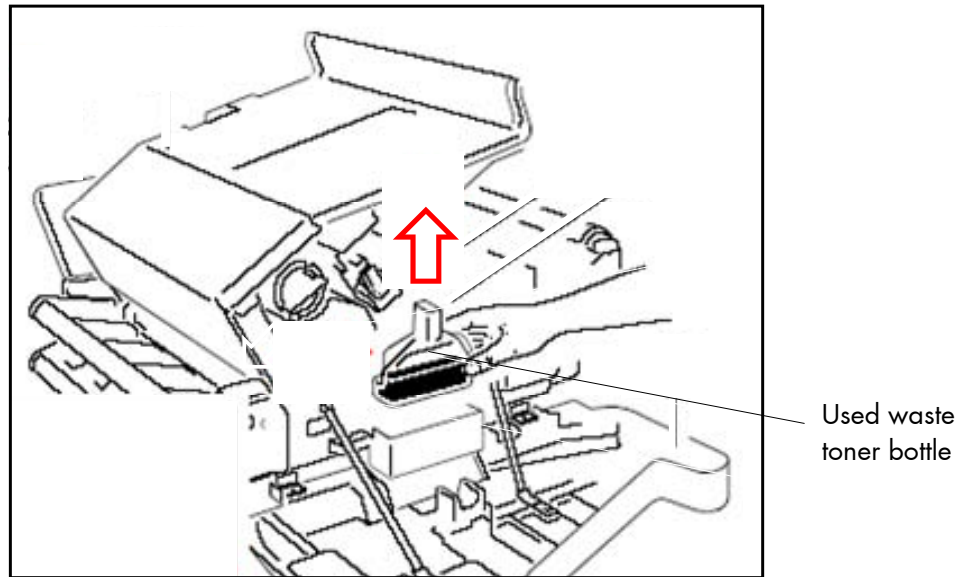

Fig. 7.3.b Removing the used waste toner bottle



6. Close the filled waste toner bottle using its cap.
Take the cap from the cap holder of the used waste toner bottle and close the filling hole with the cap (compare figure 7.3.b and 7.3.c). Take care that the cap fits tightly over the opening.
7. Clean up any toner dust and lead the old waste toner bottle to a duly disposal.
8. Take the new waste toner bottle from the toner kit.
9. Take off the cap from the new waste toner bottle and place it to the bottles cap holder.

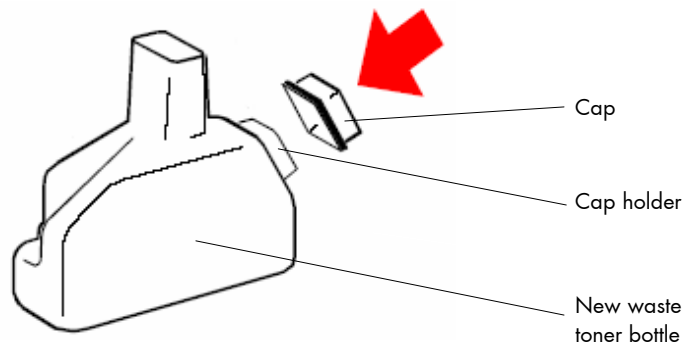

Fig. 7.3.c Preparing the new waste toner bottle

10. Insert the waste toner bottle into the printer as shown in the following figure.

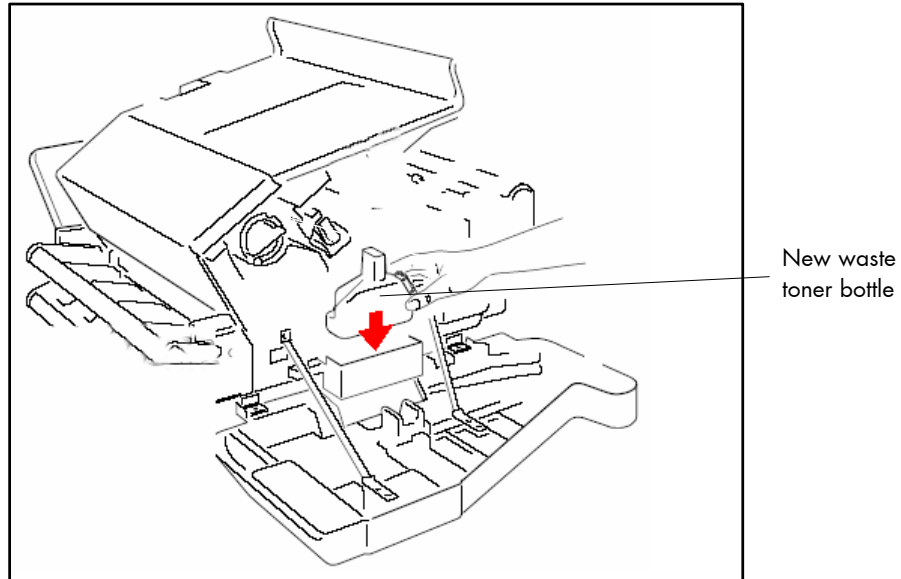

Fig. 7.3.d Installing the new waste toner bottle



Check if the cleaner felt and the ozone filter have to be replaced. (See the following sections).

11. Close the printer's top cover.

12. Close the printer's rear cover.

13. Close the printer's front cover.

7.4. Replacing the Cleaner Felt

Please check the status of the cleaner felt on every replacing of the toner cartridge.

If the cleaner felt is very dirty, it has to be replaced.

Normally, the cleaner felt has to be exchanged on every second replacing of the toner cartridge (see section 7.2). One toner kit contains 5 cleaner felts.



The cleaner felt should also be replaced, if there are any toner residues on the printouts and this problem could not be solved by cleaning the printer interior.



1. Turn off the printer and pull the power plug.

The metal bar of the cleaner felt might be very hot.

Make sure, the printer has been switched off for at least 15 minutes before you start replacing the cleaner felt.

2. Open the printer's front door.

3. Open the printer's rear cover.

4. Press the lever (see the following figure) to open the printer's top cover.

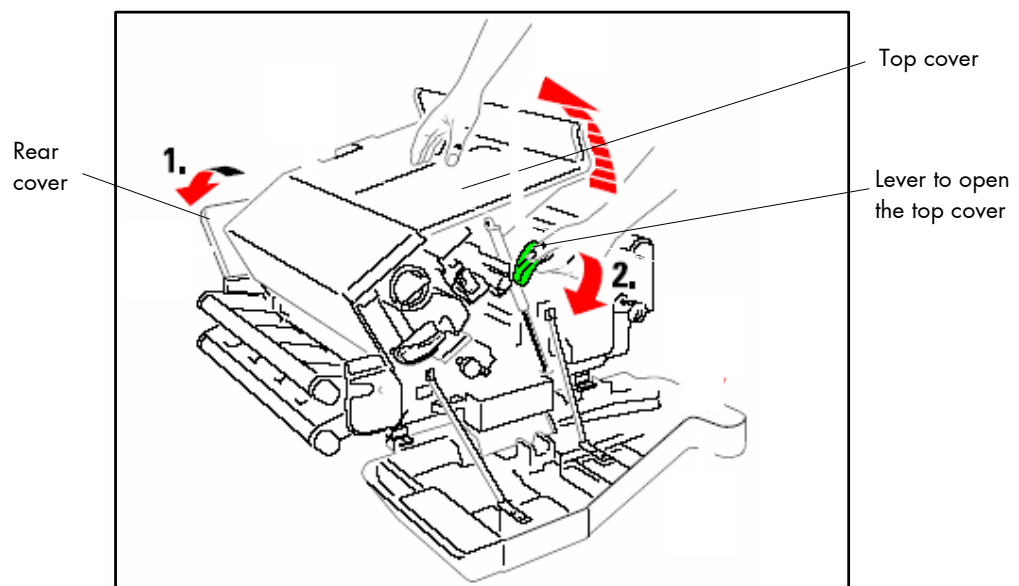

Fig. 7.4.a Opening the rear and top cover



For changing the cleaning roller the printer has to be switched off and cooled down. If the printer was in operation before, components of the fuser unit are extremely hot. Let the printer cool down for about 15 minutes before replacing the cleaner felt.

5. Remove the old cleaner felt as shown in the following figure: press both green levers in direction of the arrows and lift it.

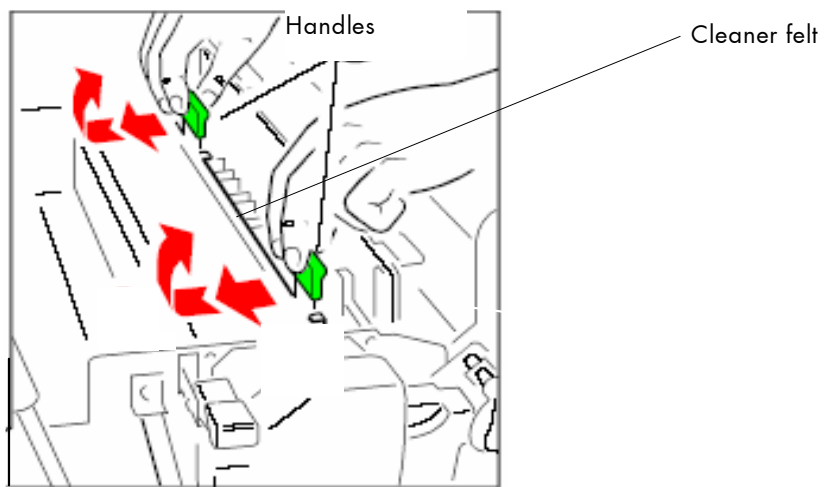

Fig. 7.4.b Removing the old cleaner felt



Don't throw away the fuser cleaner platen!

6. Remove the cleaner felt from the cleaner platen by pressing the clamp on both sides of the platen.

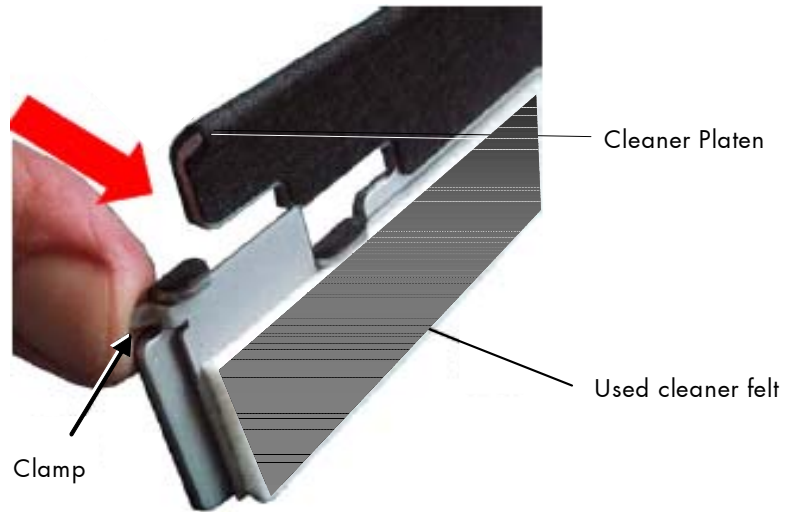

Fig. 7.4.c Removing the old cleaner felt from the cleaner platen

7. Mount the new cleaner felt with the eye in the middle (4) onto the lug (5) and press the clamp on both sides onto the cleaner platen.

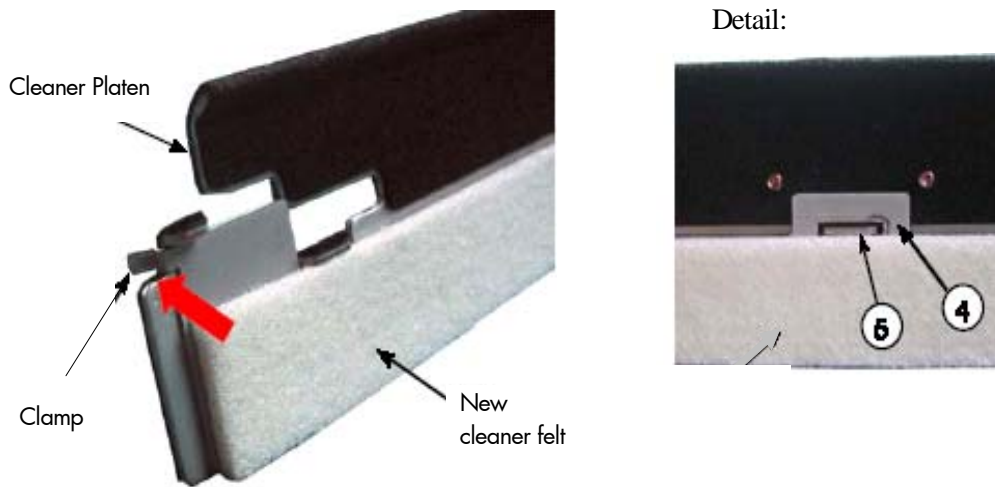

Fig. 7.4.d Mounting the new cleaner felt to the cleaner platen

8. Use both plastic handles to insert the new cleaner felt (including the cleaner platen) into the printer.

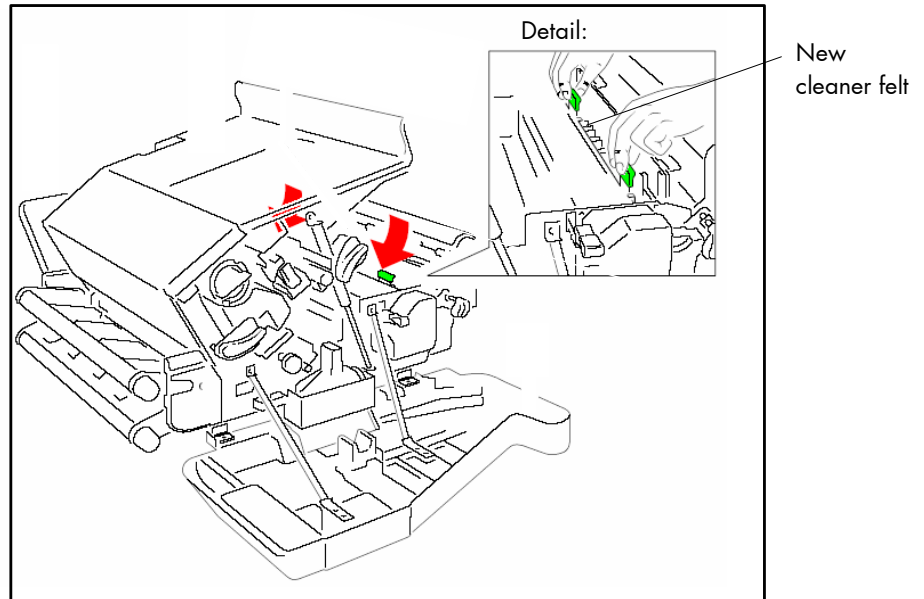

Fig. 7.4.e Inserting the new cleaner felt

Note: Depending on paper properties it might be necessary to change the cleaner felt more often than with every second toner cartridge!



Check if the ozone filter has to be replaced. (See next section).

9. Close the printer's top cover.

10. Close the printer's rear cover.

11. Close the printer's front cover.

7.5. Exchanging the Ozone Filter

Please exchange the ozone filter on every second replacing of the toner cartridge (compare section 7.2).

One toner kit contains 5 ozone filters.

1. Turn the printer OFF LINE.
2. Open the printer's rear cover.
3. Pull the ozone filter out of the printer. (Use the small tab to grasp the filter).

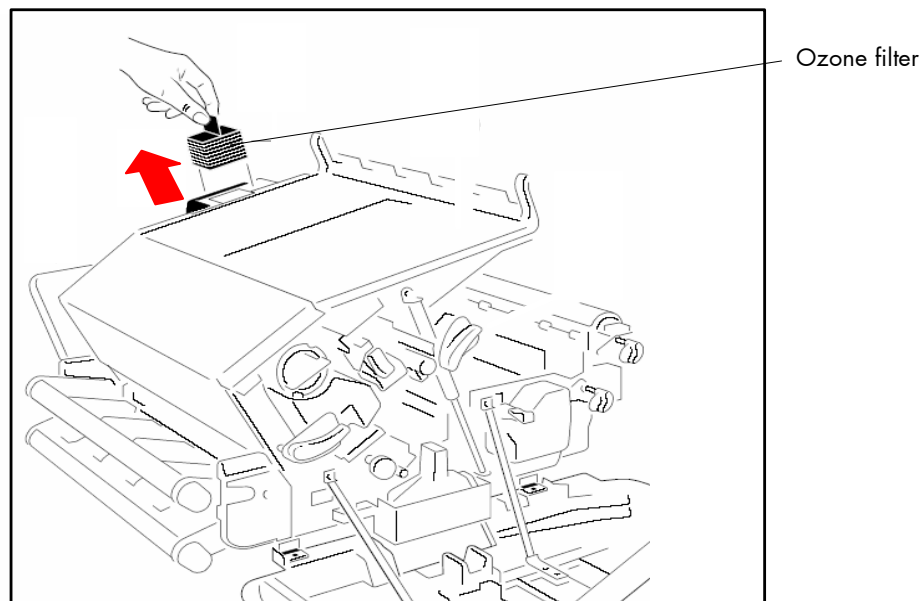

Fig. 7.5.a Removing the old ozone filter

4. Insert the new ozone filter in the opening of the printer. (Compare figure 7.5.a.)
5. Close the printer's rear cover.
6. Close the printer's top cover (in case it is open).
7. Close the printer's front cover (in case it is open).
8. Press the ON LINE key.

8. Troubleshooting



When an error occurs, a corresponding error message is displayed in the control panel (see section 8.3).

Please address the problems described in the following sections yourself, especially the consumable replacement.

Please regard the following subjects if an opening of the printer becomes necessary:



- While operating the printer components inside the device will heat up. Take care that you do not burn your fingers when removing a paper jam.
- Pay attention to the information found on the device itself (e.g. on the interior of the printer's front cover).
- Only the green components should be touched or moved.
- Make sure all covers of the device are completely closed afterwards.



Any others but the troubles described on the following pages are only to be repaired by a MICROPLEX authorized operator or a service engineer.

When reporting a problem to your service engineer, please give him the exact error message. That helps to localize the error more quickly.

8.1. Error during the Print Process

<u>Defect</u>	<u>Remedy</u>
Printer does not work	<ul style="list-style-type: none">- Check the power supply, switch on the device.- Make sure all covers of the device (e.g. the front door) are completely closed.- Pay attention to the panel messages (see section 8.3).- Check if the paper has been inserted correctly (see chapter 4 Handling of Consumables).
Frequent paper jams	<ul style="list-style-type: none">- Make sure all paper is removed from the paper path after a paper jam.- Pay attention to all information in section 8.4: Paper Jams

If the remedies above are not successful or there is an error message that is not described on the following pages please switch off the device and contact a MICROPLEX authorized service engineer.

8.2. Reduced Print Quality

<u>Defect</u>	<u>Remedy</u>
Printout too light	<ul style="list-style-type: none">- Check the density setting (see section 6.30).- If the message [Toner Empty!] is displayed: Replace the toner cartridge (see section 7.2: Replacing the Toner Cartridge).- Do not use damp paper.- If you want to print on special paper: please choose a more appropriate paper type if necessary.- Check the environment conditions and change them if necessary. Pay attention to the admissible values for atmospheric humidity, temperature etc, see also section 2.3: Environment and Power Standards.
Toner residues on the printouts	<ul style="list-style-type: none">- Clean the printer (see section 7.1.: Printer Cleaning).- If the fault is still appearing: Replace the cleaner felt of the fuser unit (see section 7.4: Replacing the Cleaner Felt).

If the remedies above are not successful, please call a MICROPLEX authorized service engineer.

Hint: Fanfold material cannot be printed in the area of the sprocket holes, even in the distance up to 5mm around the sprocket holes a reduced print quality has to be expected.

8.3. Error Messages

<u>Panel display</u>	<u>Description</u>	<u>Remedies</u>
[Warming up]	This is a warning message.	As soon as the engine's warming up is finished, the printer state automatically changes to Ready.
[Cover open !]	A printer cover is open.	Close the cover.
[Remove Paper !]	Paper in the paper path has to be removed.	Take out the paper, if necessary cut it before.
[Paper End !]	There is no paper in the printer.	Insert paper. (See chapter 4: Handling of Consumables. See also section 6.8: Tractor Cassette Selection).
[Toner Low]	The toner level is low.	This is a warning message. The next state is Toner Empty. Order a new toner kit.
[Toner Empty !]	There is no toner left in the printer.	Refill toner. (See section 7.2: Replacing the Toner Cartridge.)
[Toner Waste !]	The waste toner bottle is full.	Replace the bottle with a new one (see section 7.3).

<u>Panel display</u>	<u>Description</u>	<u>Remedies</u>
	<p>Paper Jam:</p> <p>Location of papermisfeed:</p>	
[Jam At Fuser Area]	- between transfer and fuser unit	<p>Remove the jammed paper completely from all paper paths.</p> <p>See section 8.4: Paper Jams</p> <p>Insert paper correctly.</p> <p>The outlet of printed material must not be obstructed.</p>
[Jam At Upper Feeder]	- in the area of the upper paper feeder	
[Jam At Lower Feeder]	- in the area of the lower paper feeder	
[Jam Near Drum]	- in the area of the OPC drum	
[Jam At Fuser Unit]	- near the fuser unit	
[Jam At Cutter/Exit]	- in the area of the cutter or the paper outlet	

<u>Panel display</u>	<u>Description</u>	<u>Remedies</u>
	Unit Presence Error:	
[No Transfer Unit]	- The transfer unit is missing or defective	Install the missing printer unit.
[No Waste Ton.Bottle]	- No waste toner bottle in the printer	
[No Developer Unit]	- No developer unit in the printer or the unit is defective	
[No Fuser Unit]	- The fuser unit is missing or defective	
[No Drum Unit]	- The OPC drum unit is missing or defective	

<u>Panel display</u>	<u>Description</u>	<u>Remedies</u>
	STACKER (Option):	
[Tray Full !]	- The (optional) paper stacker system is full.	Please take out the paper
[Wrong Page Length]	- Wrong page length (<7 inch or > 17 inch)	Check the paper size.

Hints:

After solving the printer problem the error message is cleared as soon as you activate the ON LINE key.

If the remedies above are not successful, please call a MICROPLEX authorized service engineer.

The following Error Messages contain Information for your Service Engineer:

Note: Only a MICROPLEX authorized service engineer should address the printer problems listed in the following tables!

<u>Panel display</u>	<u>Description</u>	<u>Remedies</u>
	MAIN HEATER TROUBLE:	
		Please inform your service engineer.
[High Temp.Main Heater]	- The main heater is unusually in high temperature	
[Low Temp.Main Heater]	- The main heater is unusually in low temperature	
[Time Out Main Heater]	- The main heater warming up did not complete within a preset time	

<u>Panel display</u>	<u>Description</u>	<u>Remedies</u>
TONER TROUBLE:		
[TPS Shift Level Not OK]	- TPS (Toner Patch Sensor) level shifts (warning; printing is continued)	Please inform your service engineer.
[TPS Dirty]	- TPS sensor surface is dirty (warning; printing is continued)	
[Too Much Feed Toner]	- Feed toner sometimes continuously but the toner density level does not become the good TPS level	
[TPS too Light]	- TPS (Toner Patch Sensor) face is too light	
[TPS too dark]	- TPS (Toner Patch Sensor) face is too dark	

<u>Panel display</u>	<u>Description</u>	<u>Remedies</u>
CHARGER TROUBLE:		
[Eraser Lamp Error]	- The eraser lamp is open	Please inform your service engineer.
[Developer Bias Error]	- The developer bias is short	
[Detach Charger Error]	- The detach charger is short	
[Transf.Charger Error]	- The transfer charger is short	
[Main Charger Error]	- The main charger is short	

<u>Panel display</u>	<u>Description</u>	<u>Remedies</u>
	MOTOR TROUBLE:	
		Please inform your service engineer.
[Retract Motor Error]	- The retractor motor does not work correctly	
[Fuser Motor Error]	- The fuser motor does not work correctly	
[Tr.Roll.Rel.Mot.Err.]	- The transfer roller release motor does not work correctly	
[Developer Motor Err.]	- The developer motor does not work correctly	
[Tractor Motor Error]	- The tractor motor does not work correctly	
[Drum Motor Error]	- The photoreceptor motor does not work correctly	
[Buffer Arm Mot.Error]	- Buffer arm positioning motor does not work correctly	

<u>Panel display</u>	<u>Description</u>	<u>Remedies</u>
FAN TROUBLE:		
[Ozone Exh.Fan Error]	- The ozone exhaust fan stopped	Please inform your service engineer.
[Suction Fan Error]	- The paper suction fan stopped	
[Frame Fan Error]	- The upper frame fan stopped	
[Main Cool.Fan Error]	- Main cooling fan stopped	
[Fuser Fan Error]	- Fuser fan stopped	
[PCU Fan Error]	- PCU fan stopped	

<u>Panel display</u>	<u>Description</u>	<u>Remedies</u>
SOFTWARE TROUBLE:		
[Printer HW Error]	- Printer engine hardware error detected	Please inform your service engineer.
[NVRAM Error]	- NVRAM error detected	
[Contr. Com. Error]	- Controller communication transmitter overrun	
[Memory Insuff.Error]	- Insufficient memory	
[Confused Error]	- The printer engine was confused or condition conflict occurred	

<u>Panel display</u>	<u>Description</u>	<u>Remedies</u>
	STACKER TROUBLE:	
[EEPROM Life]	- Stacker EEPROM life expired	Please inform your service engineer.
[EEPROM Checksum Error]	- Checksum error in stacker EEPROM (only after power-on)	

8.4. Paper Jams

Operation steps for removing a paper jam are described in this paragraph.



Please note:

- The fuser unit and the components next to it become very hot. Because of this let the printer cool down first.
- To avoid soiling your clothes please be especially careful with the components carrying toner.



By carefully selecting print materials and loading them properly you should be able to avoid most paper jams.

In case of a paper misfeed the printer shows an error message in the display of the control panel.

To resolve the paper jam attendance messages, you must clear all paper from the paper path.

8.4.1. Possible Paper Jam Areas

In the following figure the Paper Jam Error messages are assigned to particular printer components (resp. paper path sections).

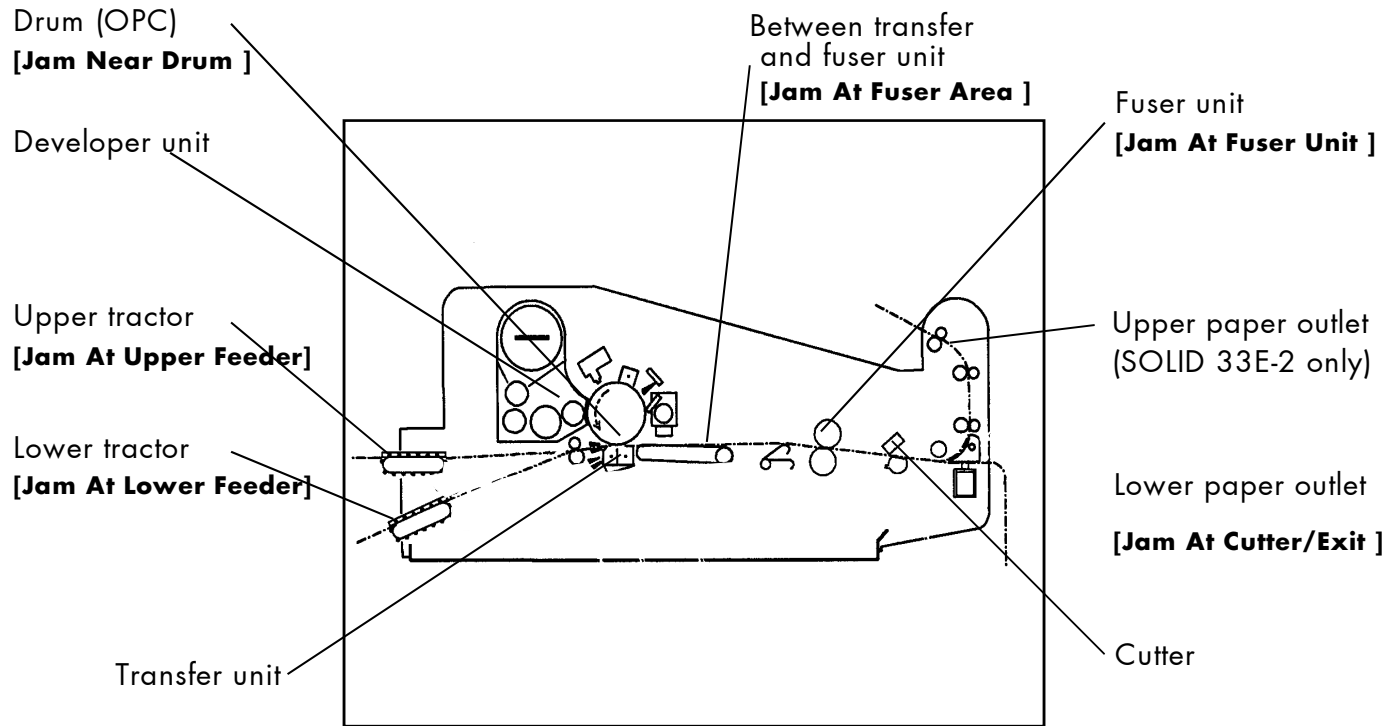

Fig. 8.4.1.a Schematic diagram of the paper paths of the SOLID 33E-2 and SOLID 58E printers incl. assignment of error messages

Notes:

For more details about removing paper jams see the following sections.

After a paper jam is removed the error message can be backouted by pressing the ON LINE key.

8.4.2. Clearing Paper Jams

If paper jams do occur, follow the steps outlined in this section.

Please note:



- The fuser unit and the components next to it become very hot. Because of this let the printer cool down first.
- To avoid soiling your clothes please be especially careful with the components carrying toner.



Please regard the following information to avoid resp. remove a paper jam:

- The jammed material only has to be removed carefully out of the printer. (Compare the following sections.)
- Crushed sheets must be disjoined at the perforation.
- Pull the paper only in transport direction out of the printer.
- The paper has to be removed completely from the paper path.
- Insert the paper new (see chapter 4).
- Check if the paper is impeccable (crushed or damped paper must not be inserted).
- Check if the paper has been inserted correctly (see chapter 4).
- Close all parts of the printer cabinet correctly.
- Press the ON LINE key to continue printing.

8.4.3. Paper Jam at the Tractor

1. Open both tractor covers (turn it to a vertical position).

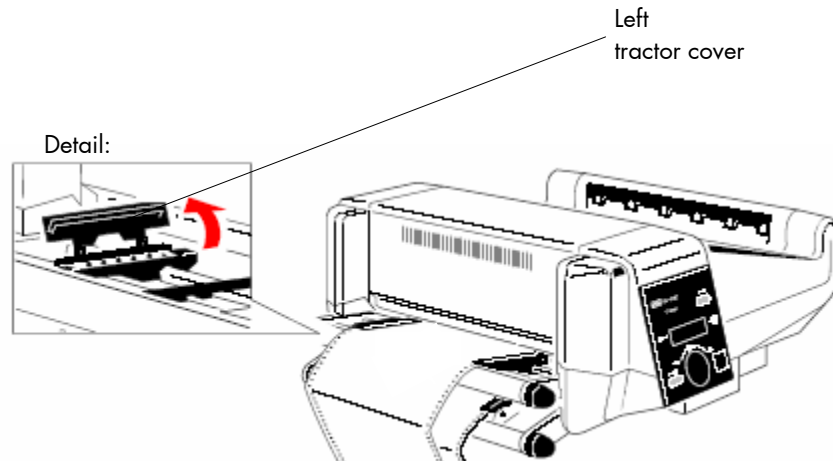

Fig. 8.4.3.a Opening the tractor covers

2. Remove the jammed paper. Crushed sheets must be disjoined at the perforation.
3. Pull the paper only in transport direction out of the printer.
4. Insert the paper new (see chapter 4).

8.4.4. How to open the Printer Covers

Open the printer as follows:

1. Open the front cover (incl. the control panel) and turn it down.



Fig. 8.4.4.a Front cover opened

2. Open the rear cover. (Compare the following figure. In opposite to the front cover it can only be tipped over.)
3. Press the lever (see the following figure) to open the printer's top cover.

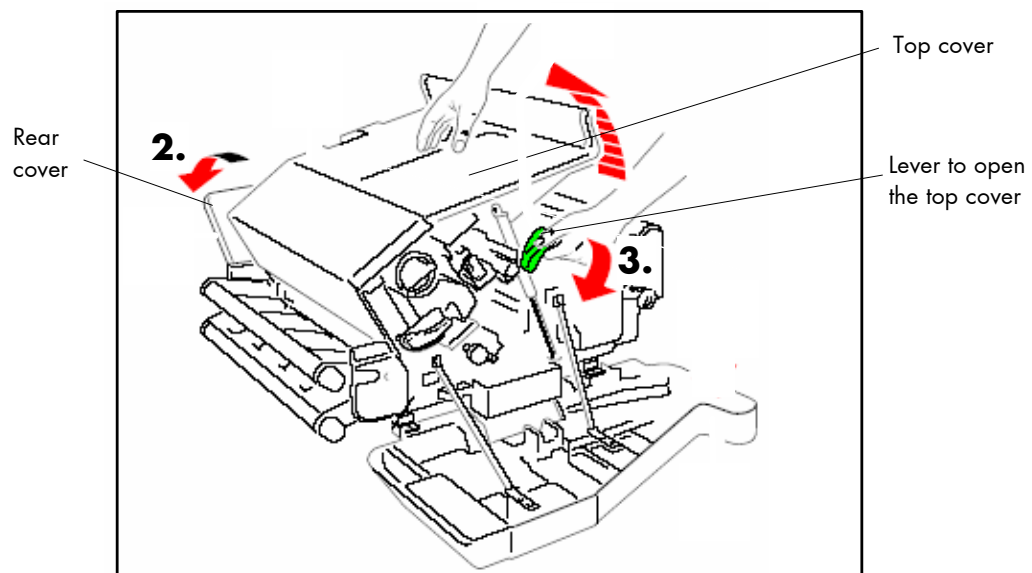

Fig.8 4.4.b Opening the rear and top cover

4. Now operate - according to the requirements - one or more of the green levers to unlock the corresponding stations.

Example:

5. Press the lever (see the following figure) to open the printer's paper exit area.

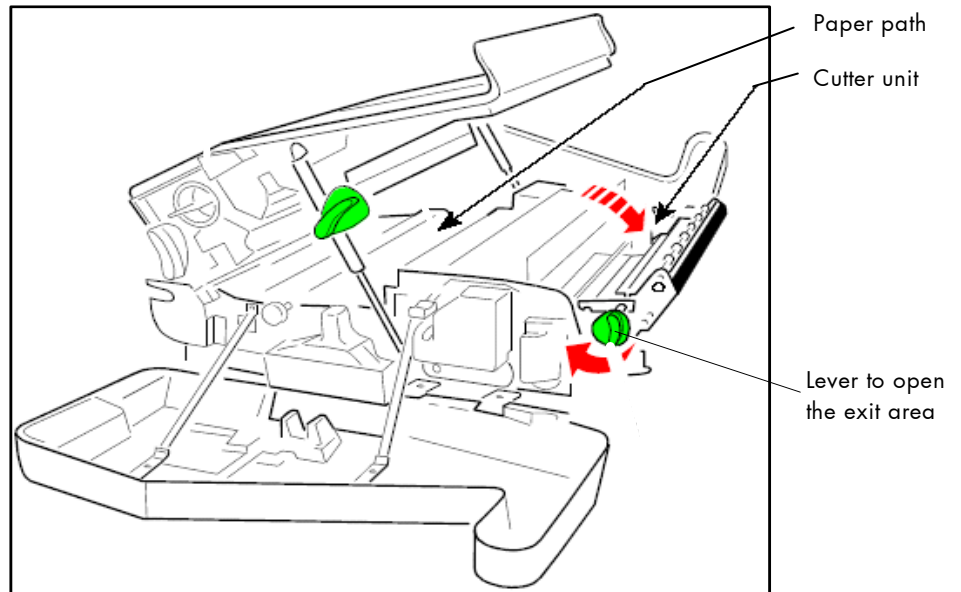

Fig. 8.4.4.c Opening the paper exit area

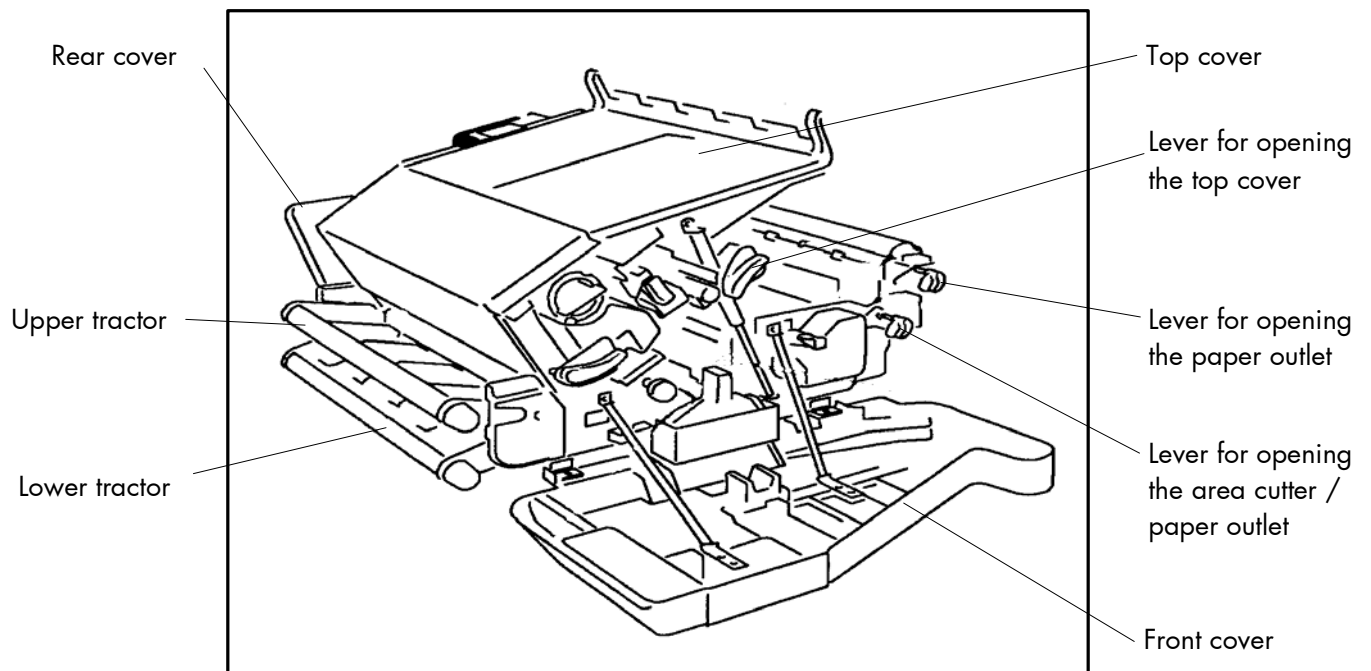

Fig. 8.4.4.d **Overview:** Printer SOLID 33E-2 / 58E opened

8.5. Print Repetition after an Error

The printer is provided with an automatic jam safety function to prevent a loss of data.

When an error occurs, all the pages on the paper path will be printed again. This ensures that no data will get lost.

The exact number of pages to repeat depends on the format length and the position where the error occurred on the page.

This automatic jam safety function can be switched off (by changing the EEPROM - configuration) if the user wants to resume the print job at a position he chooses himself.

In addition to this see panel function Clearing the Input Buffer (section 6.5).

9. Measures for Transport and Shipping (Repacking)

The Printer is shipped with special packing material and fixing measures. It is recommended to store the boxes and those packing materials.



In case of further shipping or returning of the products they must be repacked in the original way in order to avoid damaging during transportation.

The following list gives you an overview of the working steps necessary for repacking. Pay attention to the notices located on the products and the hints given in the Service Manual as well.



If you are not familiar with any of the working steps please ask your service engineer or your supplier.

- Remove the printer's optional devices
(for example: feeder, stacker, cassettes ...).
- Remove the Waste Toner Bottle from the printer and seal it.
- Remove the Developer Unit.
Close carefully the toner input and output holes
(for example using paper stripes sealed with adhesive tape).
Put the Developer Unit into its original box.
- Lock all moveable parts of the printer (use all original transport safety devices, adhesive fasteners and so on).

Repack all items in their original packing material and ship them in the original boxes.

10. Specifications

Print technology:	non-impact/electrophotographic, LED, OPC, heat pressure fusing	
Print speed:	SOLID 33E-2 up to 33 pages per minute (A4 landscape)	SOLID 58E up to 58 pages per minute (A4 Two-Up)
Resolution:	300 dpi (dots per inch, horizontal and vertical)	
Paper size:	width: 4 to 17 inches, 16" printable *)	6 to 18 inches, 17" printable *)
	length: 3 to 24 inches, with paper stacker system 7 to 17 inches	
Paper weight:	64 to 155 g/m ² (17 lb to 41 lb)	
Paper feeders:	2 separate tractor feeders (tractor cassettes)	
Interfaces:	parallel: IEEE 1284 (Centronics), (MP-BUS, SPS-Control, optional) serial: USB 1.1 Europe: RS232, RS422 LAN: Ethernet 10/100 Mbit (TCP-IP) Optional: LAN: Ethernet (SPX-IPX, LAT), Token Ring Host: IBM SCS / IPDS (Twinax/Coax), Siemens (BAM/SS-97)	
Size:	printer incl. tractor feeders: 890 mm (W) x 350 mm (H) x 780 mm (D) incl. paper stacker system (optional): 1120 mm (W) x 1160 mm (H) x 780 mm (D)	
Weight:	printer: about 112 kg (incl. consumables) printer incl. paper stacker system (optional): about 164 kg	
Noise level:	≤ 55 dB(A) operating, ≤ 48 dB(A) stand by	
Environment:	temperature: +15°C (56.5°F) to +30°C (86°F) (operating) - 20°C (- 4°F) to +40°C (104°F) (non-operating) relative atmospheric humidity: 25 to 55 %	
Mains connection:	240 V AC, 50 Hz, (Europe, United Kingdom e.g.) 115 V AC, 60 Hz, (North America)	
Power admission:	appr. 1.4 kW (average value; max. value < 1.85 kW)	

- *) Hint: Fanfold material cannot be printed in the area of the sprocket holes, even in the distance up to 5mm around the sprocket holes a reduced print quality has to be expected.

Costs per Page for MICROPLEX Print Systems

The term "costs per page" is the most frequently used one in connection with the purchase of a printer. Nevertheless this term is the one with the biggest lack of definition.

The distributors normally attach great importance to having small values for the costs per page. The user normally wants to have a value that is as realistic as possible.

There isn't any generally valid rule to calculate the costs per page. Therefore values given by different manufacturers are very often not comparable.

The values given by MICROPLEX are based on the utilization time of the so-called consumables of the printer. There isn't any generally valid rule for this calculation, either. Therefore MICROPLEX has fixed the definition of consumables as follows:

1. Consumables

Consumables are parts or substances which the user can exchange or refill without tools.

MICROPLEX understands by this definition that the user can decide by visible criteria when he should exchange or refill consumables. The working steps can be done by the user in accordance with the manual without the usage of tools.

Consumables can be different depending on the printer type.
The most important consumable for example is **toner**.

Usually the utilization time of these materials is given as a number of pages (DIN A4). These values often refer to the print density (3%, 4%, or 5%) which is given as an application specific parameter. Usually a value of 5% print density is defined, very seldom is 4% used.

In the case of a low print density (e.g. 3%) the utilization time increases, in the case of a high print density (e.g. 10%) the utilization time is decreased.

Therefore the utilization time is strongly dependant upon the application.

Experience proves that in professional applications a print density of higher than 5% is usually reached. For a delivery note containing a form and some bar codes a print density of 8 - 10% is quite normal.

There are further parts that must be exchanged in addition to the consumables during the life time of a print system. MICROPLEX divides these additional parts into two categories:

2. Application specific wearing materials

Application specific wearing materials are parts which have to be exchanged by a service engineer or a trained operator. The criterias for the exchange aren't always easily recognizable for a user. Some of the criterias require measuring techniques or the experience of a service engineer or operator.

In a normal application, parts of this category are:

- fuser unit
- process unit (drum, OPC)
- ozone filter

3. Spare parts

Spare parts are exchanged by the service engineer, when they fail.

Examples for spare parts are:

- couplings
- electronic assemblies
- rollers

Depending on the application some parts may change categories under certain circumstances. If for example very rough paper is used, the rollers can become an (application specific) wearing part.

It's a fact, that the right time to exchange a component depends not only on the failure of a component but also on a possible loss of print quality in the printouts.

MNPSQ = Mean Number of Prints with Specified Quality (**SQ**).

This value is often associated with "Lifetime". This term is not correct. MNPSQ describes the period of time in which a defined print quality is maintained.

The print quality is determined by the values for

- print density
- background darkness
- homogeneity

The value **IQ** (Initial Quality) is used to designate the print quality that is reached with a new printer.

CAQ (Customer Acceptable Quality) is a purely subjective lower limit which a respective customer is willing to accept the print quality. An exchange of parts is only then necessary even if the MNPSQ is already exceeded.

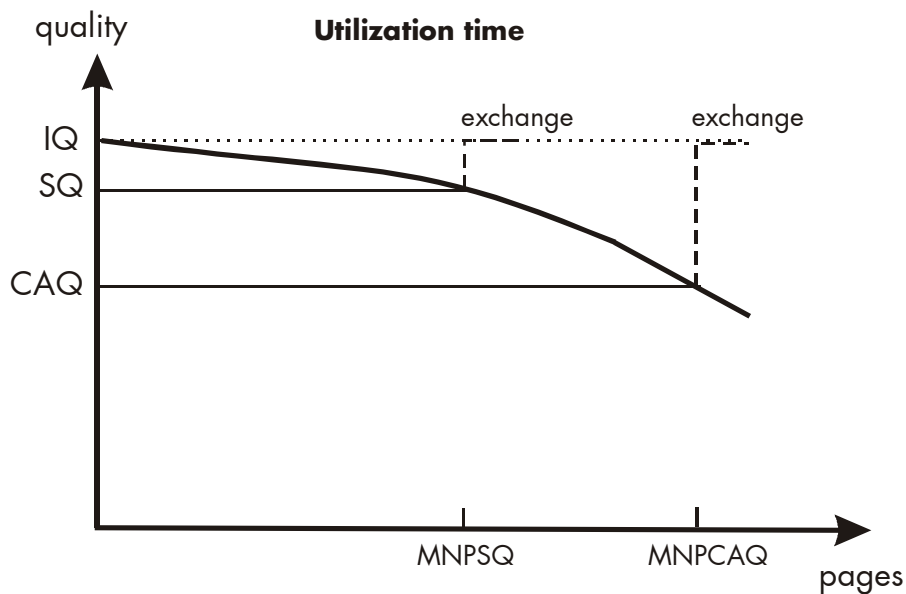

11. Index

A

automatic paper stacker system 45

B

BUTTON 49, 50

BUTTON, press the 55

BUTTON, turn the 55

C

cancel job 64

CE - conformity 10

check list 13

cleaner felt 29

cleaner felt, fuser unit 116

cleaning 101

configuration 51, 59, 80

connect, printer to a PC 47

consumables 13, 35, 143

contents 3

continuous materials 35, 37

control panel 49, 51

control panel elements 50

conventions 9

costs per page 143

Cover open ! 124

covers 136

cutter 7, 43, 50

cutting mode 93

cutting position 91

D

danger 9

data interface 74

density 97

detergent 102

developer unit 21

diagrams 57

display 50

display language 77

E

EEPROM Error 131

emergency power-off 11

emulation 75

environment 17, 141

error messages 121, 124

ESCAPE key 49, 50, 55, 56

extended menu 53

F

factory default 80

fanfold paper 7, 35, 37, 141

first installation 13, 20

font bank 60

Font List 61

font number 81

fonts 81

FORM FEED 63

format width 72

H

Hexdump 62

humidity 18, 141

I

IDOL 78
image shifting 87, 89
input buffer 79
input buffer clearing 64
installation 13, 20
interfaces 16, 74, 141
IP address 98

K

KEY key 49, 50

L

language 77
levers 136

M

mains connection 141
material supply 42
measures, transport 139
memory distribution 79
menu page 65
menu structure 53

N

network parameters 98
noise level 141
normal print mode 63

O

ON /OFF LINE switching 52
ON LINE key 49, 50, 54, 56
operation 52
operation sequences 33
operator maintenance 101
ozone filter 30, 120

P

packing materials 14, 20
page description language 78
page format 70
page length 45, 69
panel display 52, 57
panel functions 59, 65
panel keys 50, 54, 57
Paper End ! 124
paper feeder 67, 141
Paper Jam ! 125
paper jam clearing 125, 132, 134
paper magazine 37
paper size 7, 69, 141
paper stacker 43
paper stacker system 7, 15, 45
paper weight 141
paper width 72
PC cartridge 31
permanent configuration changes 55
permanent function changes 51
power admission 141
power on 52
power save time 96
power standards 17
power switch 15, 47
print density 144
print direction 73
print pages per page format 70
print quality 144
print repeat 138
print speed 141
print technology 7, 141
print width 72
printer components 15
printing basics 8

R

radiation 10
reduced menu 53
relative atmospheric humidity 18, 141
Remove Paper ! 124
repacking 139
required space 17
resolution 7, 141
returning 139

S

safety information 10
shipping 139
size 141
Sliding Pattern 66
spare parts 144
specifications 141
stacker 68
stacking lattice 46
standby time 95
status messages 52
status sheet 59
symbol code 85
symbols 9

T

temperature 18, 141
temporary configuration changes 55
temporary function changes 51
text margins 86
text orientation 84
toner cartridge 108
toner cartridge 24
Toner Empty! 124
Toner Low 124
Toner Waste ! 113, 124
troubleshooting 121
tractor 135
tractor cassette selection 67
tractor cassettes 35
tractor cover 135
Transparent Code 78
transport 139
Tray Full ! 126
troubles 121
two-up mode 70

U

utilization time 143

V

ventilation 18

W

waste toner bottle 27, 113
weight 141
Wrong Page Length 126