

SOLID 50 A3 - 3

Operator's Manual

Edition 2.1M



Table of Contents

Chapter	Page
1. Introduction	7
1.1. General Description	7
1.2. Conventions	9
1.3. CE - Conformity	10
1.4. General Safety Instructions	10
2. Installation	13
2.1. Check List	13
2.2. Printer Unpacking	14
2.3. Preparing the Printer	17
2.4. Printer Installation	26
2.5. Printer Components	30
3. Handling of Consumables	32
3.1. Print Media Handling (Paper, e.g.)	32
3.1.1. Loading Cassettes 1 and 2	32
3.1.2. Loading the Multipurpose Feeder	38
3.1.3. Using the Output Bins	41
3.1.4. Changing the Paper Size Setting	42
3.2. Toner Cartridge Replacing	44
3.3. Drum Cartridge Replacing	51
4. Operation and Menu Structure	59
4.1. Attaching the Printer to a Computer	59
4.2. Turning on the Printer	59
4.3. Control Panel View	61
4.4. Function of the Control Panel Elements	62
4.5. Configuration via the Control Panel	64
4.6. Menu Structure	65
4.7. Syntax of Diagrams	70

Chapter	Page
5. Panel Functions	71
5.1. Printing the Status Sheet	71
5.2. Printing the Font List	73
5.3. Choosing Print Resolution	74
5.4. Hexdump-Mode Activation	76
5.5. Normal Print Mode Activation (incl. FORM FEED)	77
5.6. Clearing the Input Buffer (Cancel Job)	78
5.7. Printing the Menu Page	79
5.8. Generating Testsheets (Sliding Pattern)	80
5.9. Feeder (Cassette) Selection	81
5.10. Stacker Selection	83
5.11. Print Mode Selection (Simplex/Duplex)	85
5.12. Paper Size Selection	87
5.13. Enabling Format Check	88
5.14. Print Direction Selection	89
5.15. Data - Interface Configuration	90
5.16. Emulation Selection	91
5.17. Display Language Selection	93
5.18. Transparent Code Adjustment	94
5.19. Selection of Memory Distribution (Input Buffer)	95
5.20. Setting to Factory Default	96
5.21. Font Selection	97
5.22. Text Orientation Selection	100
5.23. Symbol Code Selection	101
5.24. Configuration of Text Margins	102
5.25. Image Shifting to the X-Direction	103
5.26. Image Shifting to the Y-Direction	105
5.27. Lines per Inch Setting (Line Spacing)	107
5.28. Number of Characters per Inch Setting (Character Spacing)	108
5.29. Print Density Setting	109
5.30. Configuration of Network Parameters (IP Address, e.g.)	110

Chapter	Page
6. Operator Maintenance	113
6.1. Printer Cleaning	113
6.1.1. Printer Cabinet Cleaning	113
6.2. Replacing the Transfer Roller and Fuser	114
7. Troubleshooting	125
7.1. Error in the Print Process	126
7.2. Reduced Print Quality	127
7.3. Error Messages	128
7.3.1. Consumables Missing	128
7.3.2. Error in Paper Transport	129
7.3.3. Service Call	129
7.4. Print Media Jam	130
7.4.1. Avoiding Jams	130
7.4.2. Clearing Jams from the Printer	132
7.4.3. Clearing Jam inside Cassette 1 and the Toner Cartridge Area	135
7.4.4. Clearing Jam inside Cassette 2	138
7.4.5. Clearing Jam inside Cassette 3 and Cassette 4	140
7.4.6. Clearing Jam inside the Multipurpose feeder	142
7.4.7. Clearing Jam inside the Duplex Unit	143
7.4.8. Solving Paper Feed Problems	145
7.5. Print Repeat after an Error	147
8. Measures for Transport and Shipping (Repacking)	149
9. Specifications	151
10. Index	155



6 Table of Contents

1. Introduction

1.1. General Description

The print system SOLID 50 A3 - 3 works on an electrophotographical base employing a laser as exposure unit.

The resolution of 600 dots per inch is corresponding to about 24 pixels per mm (see section 5.3: Choosing Print Resolution).

The maximum print speed is 50 pages per minute (Letter or A4).

This SOLID printer is able to process different paper qualities with a weight from 64 to 163 g/m. Paper sizes like A3, A4 and A5 are fed from adjustable cassettes.

The SOLID 50 A3 - 3 ships with two adjustable 500 sheets cassettes, a multipurpose feeder and a duplex unit for automatic front and back side printing as a standard.

A multitude of options are available:

- two additional 500 sheets cassettes
- a 3,500-sheets finisher/stacker
- a 2,000-sheets high capacity feeder

This listing of options isn't complete – please ask your supplier for more information. All options promote the excellent paperhandling functionality of the SOLID 50 A3 - 3 printers.

The special advantage for SOLID-system users is based on the integrated MICROPLEX high performance controller. The controller prints different information, such as text, bar code, vector graphics and TIFF images in rated speed.

The controller "understands" most of the current emulations and is compatible with different types of networks.

More importantly, the MICROPLEX controller offers its own language, known as IDOL. The IDOL emulation offers a multitude of convenient forms management and copying functions.

The MICROPLEX printer controller has its integrated website, this allows a printer configuration via Ethernet. See [Networking Features of MICROPLEX Printers](#) for more information.

Fundamentals of Digital Printing

Digital information (like a form with text, a company logo and vector graphics) is transferred from the EDP - system to the laserprinter's input buffer in a coded manner called an "emulation" or "page description language". The controller decodes information and defines letters, numbers, graphics, etc. into bit patterns and posts them into the controller's frame store. This way, a copy of the future print which is generated by dots is produced.

The electronically controlled laserbeam now plots this dot pattern in rows onto a rotating, light-sensitive negatively charged drum. At those drum spots impacted by the light the electronic charge is extinguished. The negatively charged toner will stick to these spots. Because similar charges repulse each other the remaining drum surface stays blank. The paper is guided past the drum, while the electrostatically charged toner particles are attracted by the paper. This process is supported by a positively charged field that is below the paper (transfer charger). When transported further, the toner particles, which are affected by heat and pressure, are combined resistantly with the paper inside the fusing unit. The drum is discharged and cleaned.

1.2. Conventions

To find the requested information more quickly and to understand instructions more easily, the following symbols are used:



This symbol refers to a possible source of danger. If you do not pay attention to this information, injuries may result, the functioning of the printer could be reduced, or the device could be damaged.



This symbol refers to important hints and suggestions on using the printer. Disregarding these hints might cause problems with the printer or within the environments.

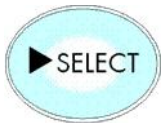

This symbol represents a key of the control panel. Such symbols will be used in this manual whenever control panel buttons must be pushed in order to activate certain functions.

[blue colored text](#)

Link to another chapter or a different document. By clicking the blue colored text you'll enter the concerning chapter or document.

[Menu Level 1]

This symbol represents messages shown in the display.

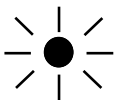

This symbol shows a shining LED (light emitting diode). The SOLID printer panel is provided with one LED.



This symbol shows a flashing LED.



This symbol will be used in this manual to show an LED that is not shining.

1.3. CE - Conformity

The manufacturer hereby declares that the device complies with the following guidelines.

2004/108/EG (EMC directive)

2006/95/EG (Low-voltage directive)

Applied harmonized standards:

EN 55022:2006 Class A (Information technology equipment -
Radio disturbance characteristics – Limits
and methods of measurement)

EN 61000-6-2:2005 (EMC: Immunity for industrial environments)

1.4. General Safety Instructions



This device produces, employs and possibly radiates high frequency energy. Because of this, incorrect installation can disturb radio communications.

Laser Notice

This printer is certified as a Class 1 laser product (DHHS Department of Health and Human Services).

The laser system and printer are designed so there is never any human access to laser radiation above a Class 1 level during normal operation, user maintenance, or prescribed service condition.



All handling or procedures that differ from the ones being described in this manual are to be omitted. Disregarding might release dangerous laser radiation.

This MICROPLEX product and its consumables are designed and tested according to strict safety standards.

By heeding the following instructions, the user is ensured safe operations:



- Please make sure your electricity source is properly grounded.
- Install the device on solid and level ground.
- Only trained staff are authorized to transport the equipment.
- Only use consumables which are specially developed for this device.



- Using improper consumables may cause a reduction of output quality or damage to the device.
- Ensure no liquids get on or into the device.
- Do not remove any cover or safety device fastened by screws.
- Do not bridge a safety device.
- Do not push anything into the ventilation apertures.



- Never carry out installations, cleanings, or maintenance operations which are not described in this manual. These operations should only be done by MICROPLEX authorized service personnel.



In order to disconnect the printer quickly from the main power in the event of an emergency, please note the following:

- For printers connected by a plug, the power-outlet should be installed near the printer and easily within reach.
- For permanently connected printers, an easily accessible emergency power-off switch should be installed close to the printer.
- Please do not conceal the disconnect devices with the printer or other objects.



- Please follow all the instructions and hints directly attached to the device and/or described in this manual.
- To ensure optimum printer performance, only use MICROPLEX consumables.

2. Installation

2.1. Check List

First, place the printer and the accessories onto a level surface until the final location of the printer is chosen.

Please make sure that there are no transport damages and that everything is included.

Damages should be reported to the supplier immediately.

Carefully open the box to make sure the following contents are included:

1. SOLID 50 A3 - 3 printer
2. Drum cartridge
3. Toner cartridge
4. Power cord
5. CD containing:
 - SOLID 50 A3 - 3 Operator's Manual
 - Print drivers
 - IDOL Manual



Please retain the original packing materials in case the printer has to be transported in the future.

Use the original packing materials and adhesive fasteners to avoid damage to the internal components.

(See chapter 8 Measures for Transport and Shipping (Repacking)).

2.2. Printer Unpacking

1. Open the cardboard box as shown in the following figure and remove the top element.

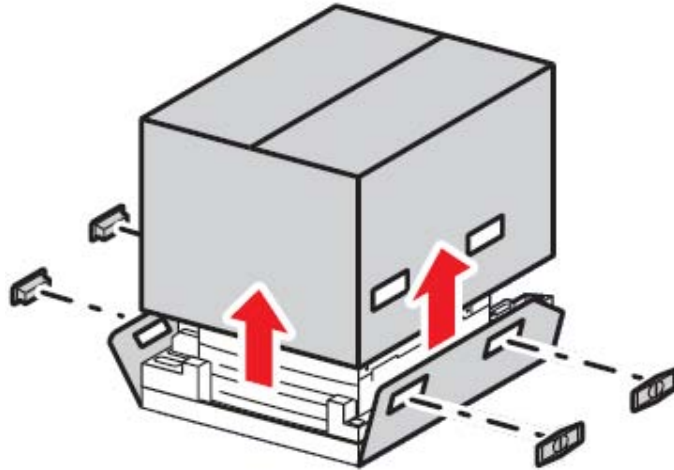

Fig. 2.2.a Opening the cardboard box



CAUTION! The printer weighs approximately 48 kg (106 lbs) and requires at least two people to lift it safely.

2. Carefully take out the SOLID printer.

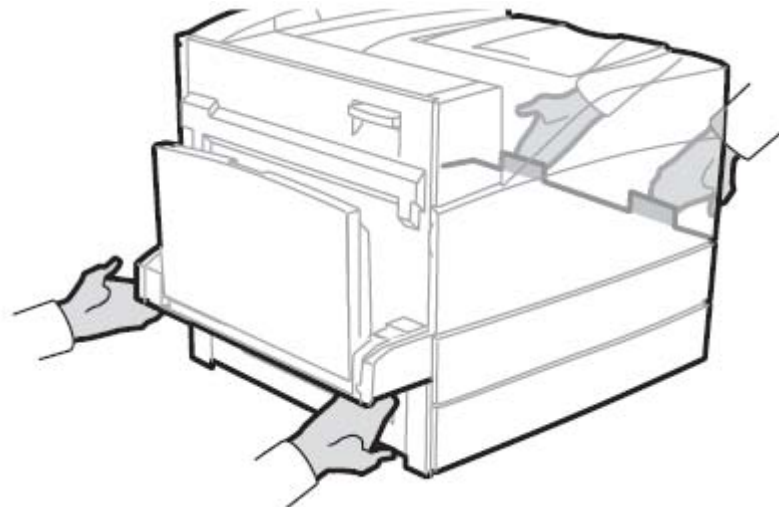

Fig. 2.2.b Lifting and transporting the printer safely

3. Place the printer in an acceptable atmosphere (see section 2.4: Printer Installation).
4. Remove all the packing materials and the adhesive fasteners (compare the following figure).

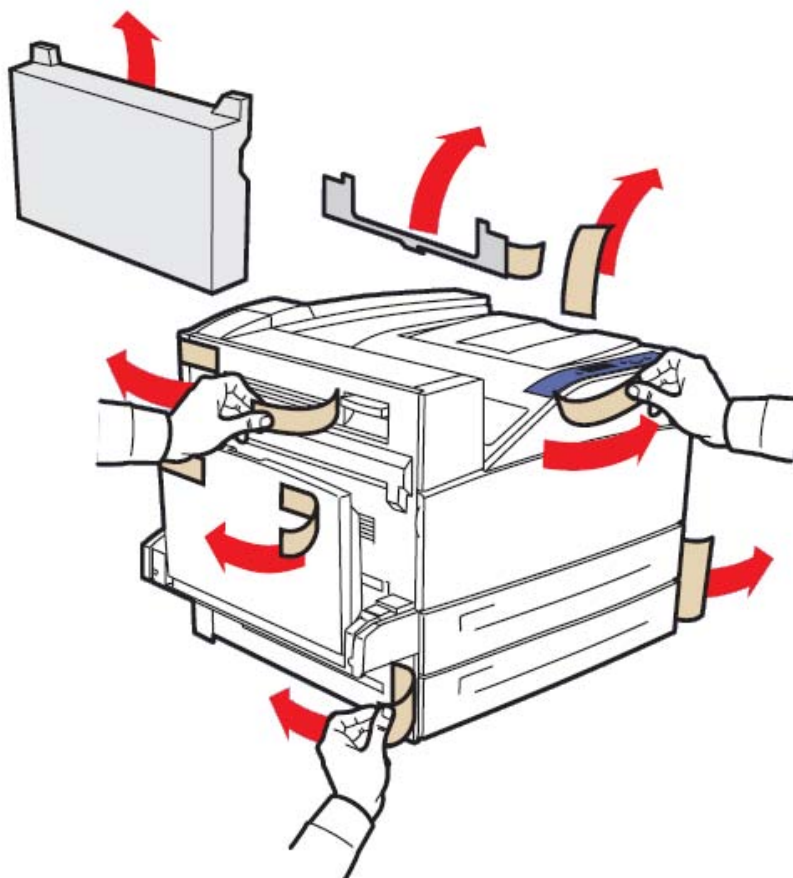

Fig. 2.2.c Removing the packing materials and adhesive fasteners

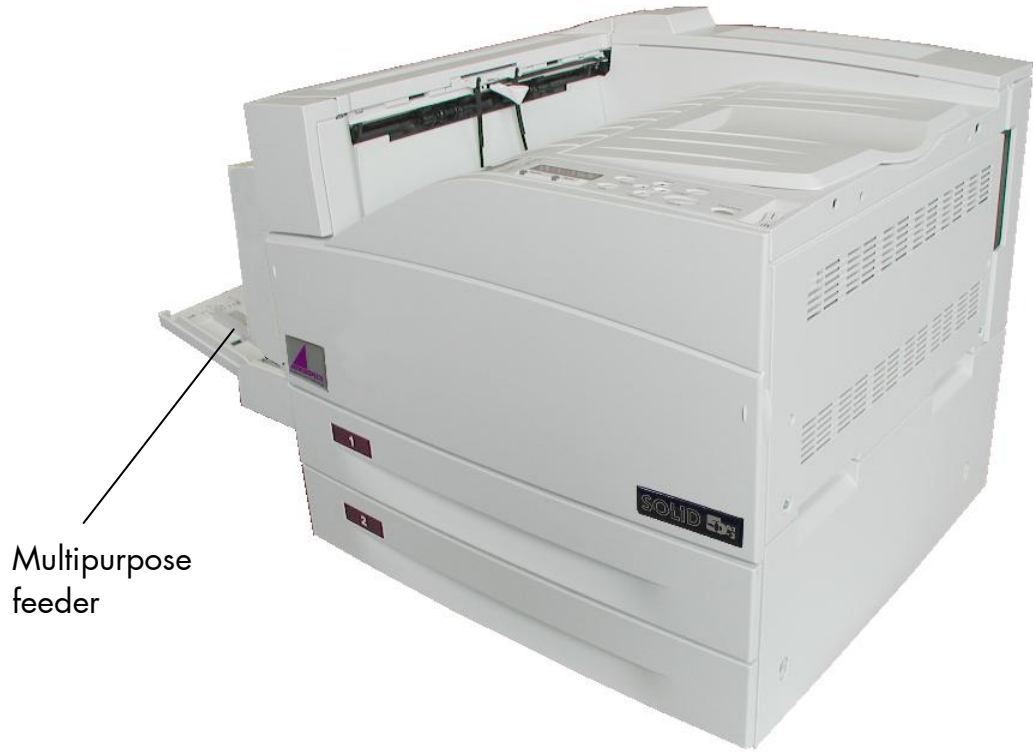

Fig. 2.2.d View of a SOLID 50 A3 - 3 printer



Please retain the original packing materials in case the printer has to be transported in the future.

2.3. Preparing the Printer

You have unpacked your printer and chosen a location for it. Now you are ready to set up printer supplies.

Installing the Drum Cartridge

1. Pull up on the handle to open the printer side door (Door A).
2. Gently lower the door to the open position.

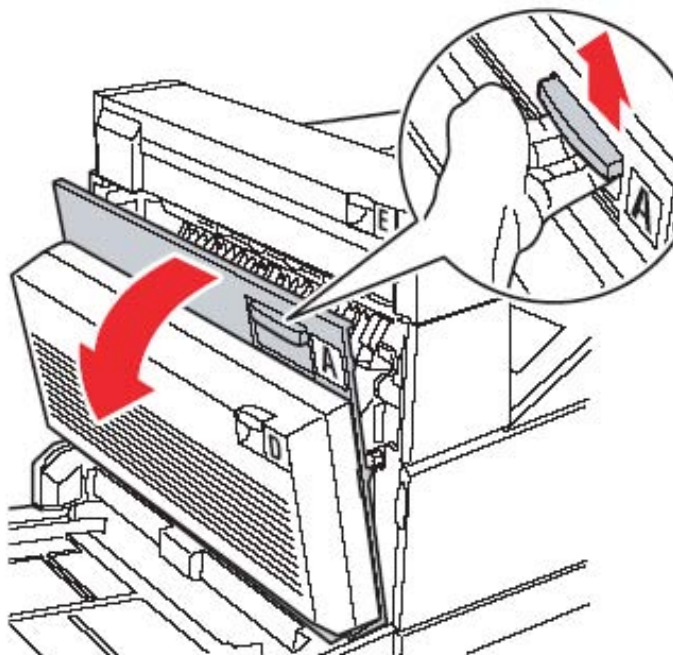

Fig. 2.3.a Opening the side door (door A)

3. Using the handholds located on each side, pull open the printer front door (Door F).

Note: You must open the printer side door since some of the following working steps cannot be performed with just the printer front door opened.

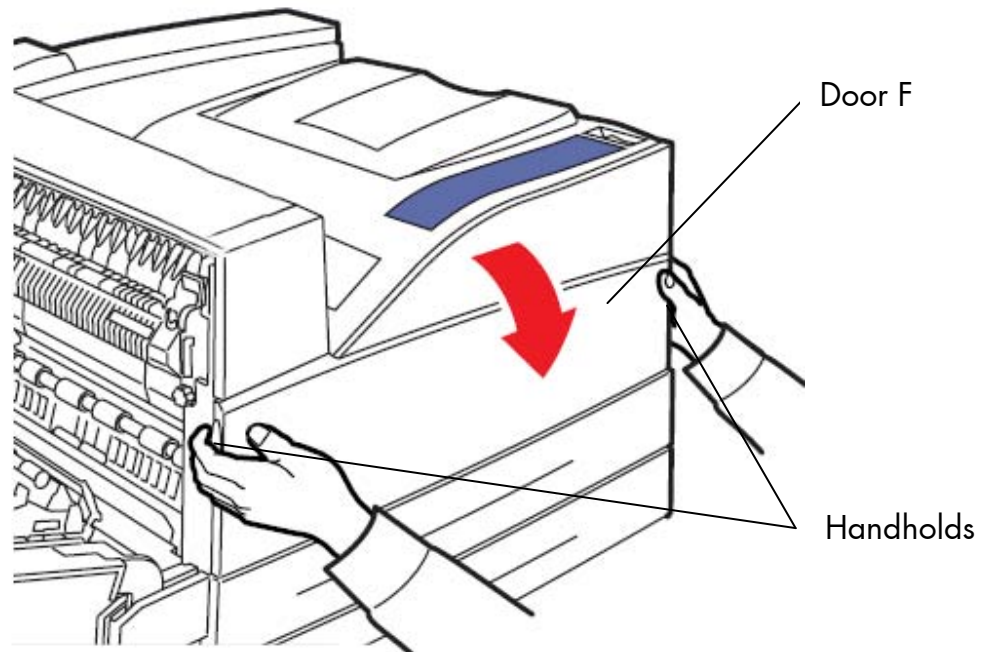

Fig. 2.3.b Opening the printer's front door (door F)



Please store the drum cartridge in its original packing until it is installed.

Extreme fluctuations of atmospheric humidity and/or temperature are not allowed.

The values listed in section 2.4 need to be met.

4. Take the new drum cartridge out of its packing.
Save the plastic bag.



Do not remove the yellow tape from the drum cartridge at this point. This has to be done in step 10.

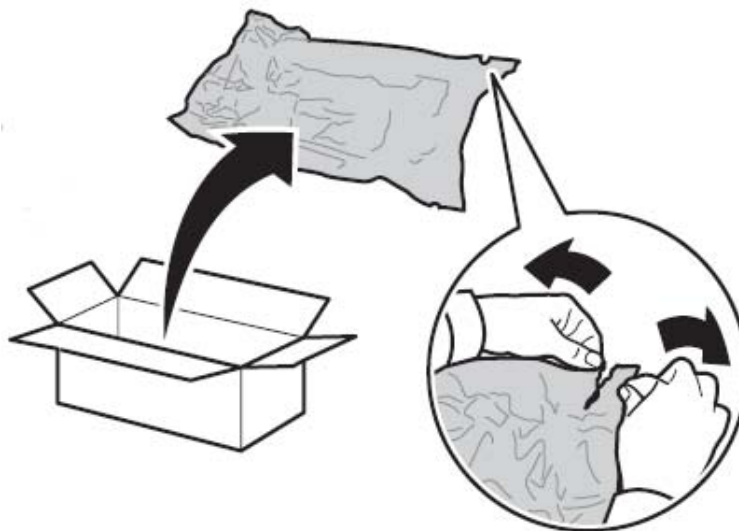

Fig. 2.3.c Unpacking the new drum cartridge

5. Turn the drum cartridge so that the handle is on top.
6. Remove the tape (on the top of the cartridge; see figure 2.3.d) and then gently pull the protective paper straight up and out of the cartridge.

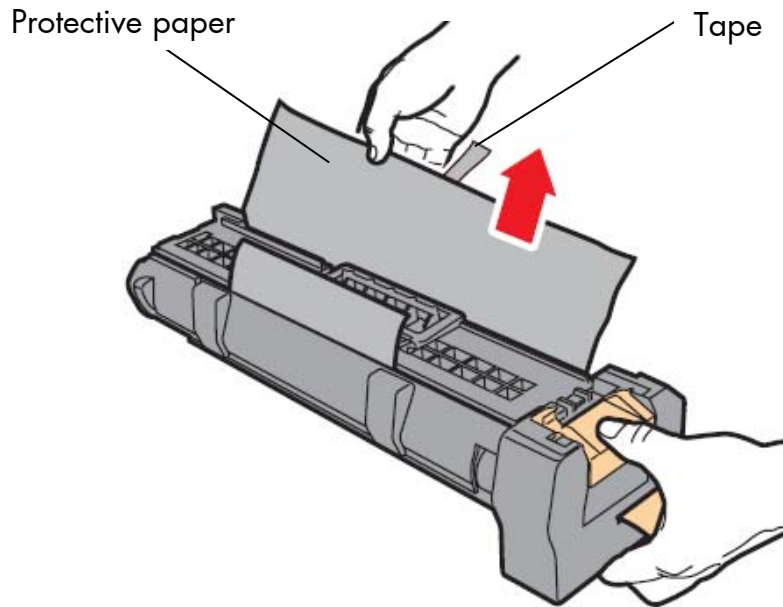

Fig. 2.3.d Removing the protective paper of the new drum cartridge



Do not leave the drum cartridge exposed to light for extended periods of time.

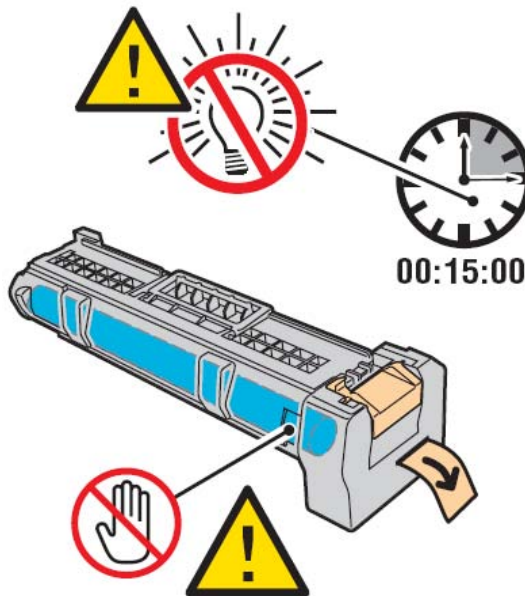

Fig. 2.3.e Hints about the drum cartridge

7. Holding the new drum cartridge by the handle and one end, align the cartridge with the slots inside the printer and slide the drum cartridge halfway in.

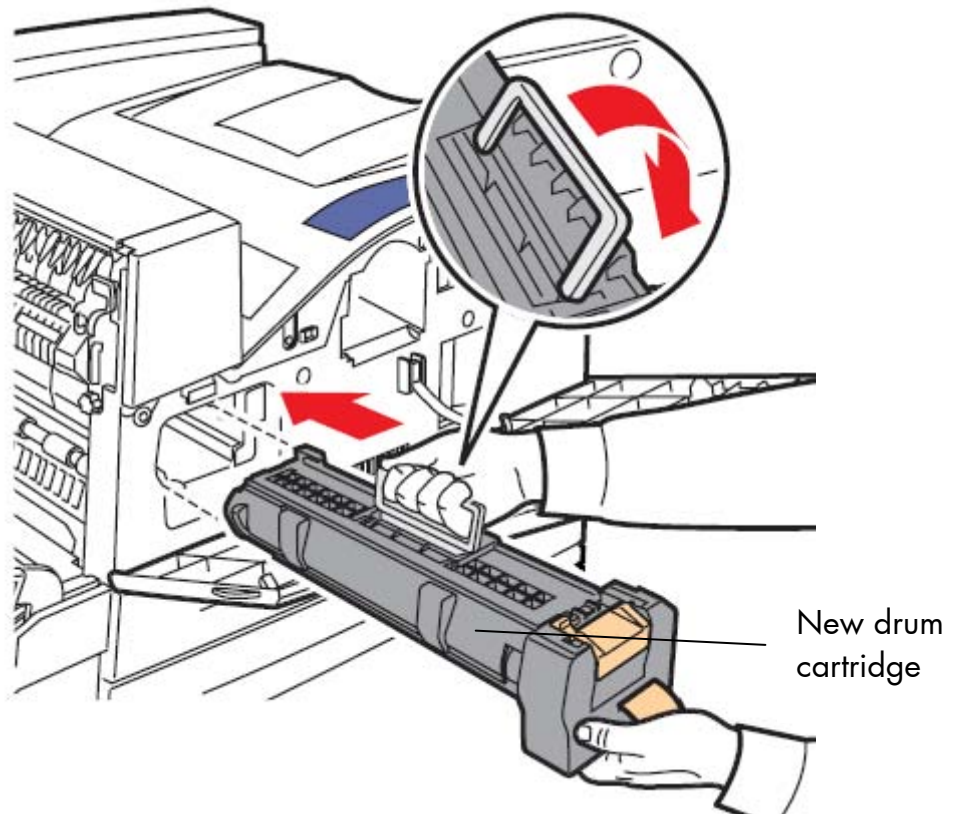

Fig. 2.3.f Inserting the guides of the new drum cartridge

8. Drop the handle back into place.
9. Push the drum cartridge into the printer until the cartridge clicks into place.

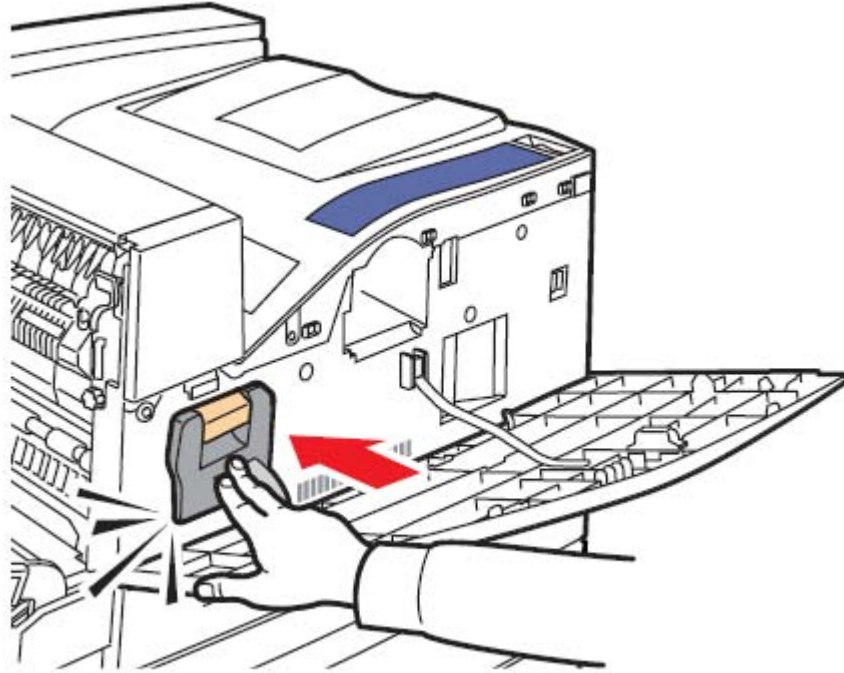

Fig. 2.3.g Inserting the new drum cartridge

10. Carefully pull the yellow tape completely out of the cartridge.
Discard the tape.

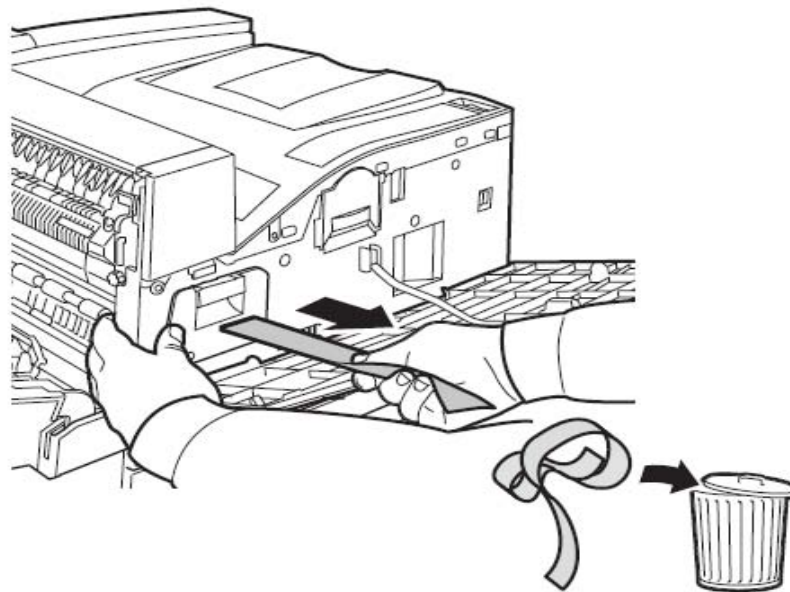

Fig. 2.3.h Removing the yellow tape

Installing the Toner Cartridge

1. Take the new toner cartridge out of its packing.

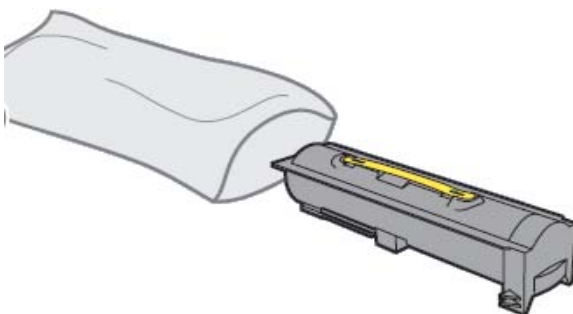

Fig. 2.3.i Taking the new toner cartridge out of its packing

2. Turn the cartridge so that the handle is on top.
3. Shake the cartridge vigorously in all directions (as shown in figure 2.3.j) to distribute the toner .



If toner spills on the floor, do not clean it up using a vacuum or a wet cloth. Wipe up the spill with a dry cloth. If toner gets on clothing, be sure to wash the clothing in cold water.

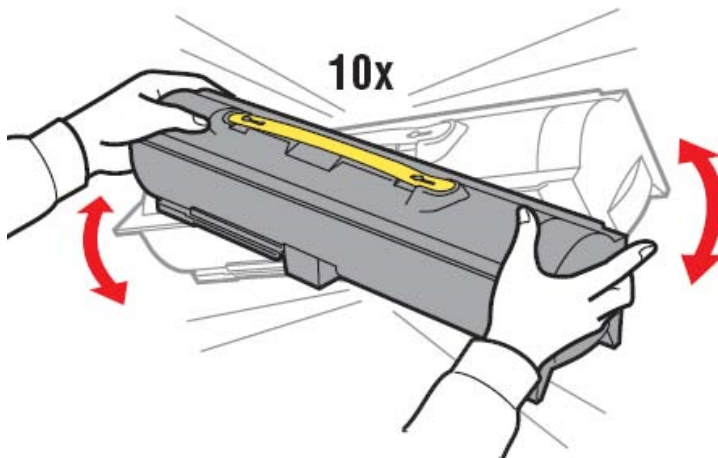

Fig. 2.3.j Shaking the toner cartridge

4. Holding the new toner cartridge by the handle and one end, align the cartridge with the slots inside the printer and slide the toner cartridge halfway in.

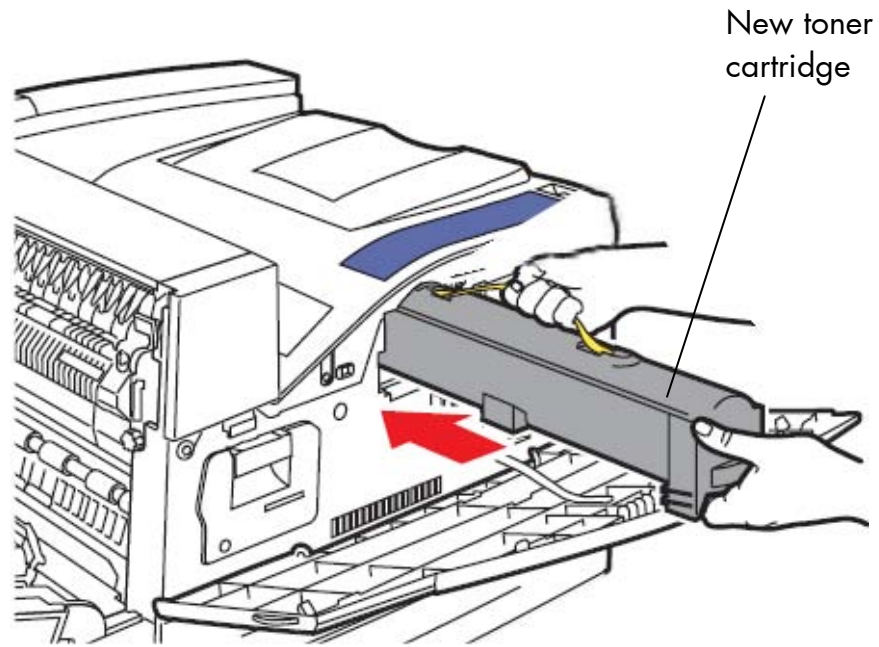

Fig. 2.3.k Inserting the guides of the new toner cartridge

5. Push the toner cartridge into the printer until the cartridge clicks into place.



Fig. 2.3.l Inserting the new toner cartridge

6. Close the printer side door (Door A).

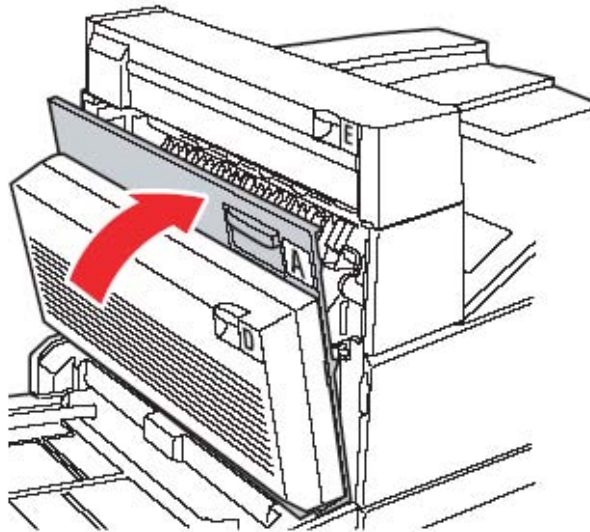

Fig. 2.3.m Closing the printers side door (door A)

7. Hold both sides of the printer front door (Door F) and close it.

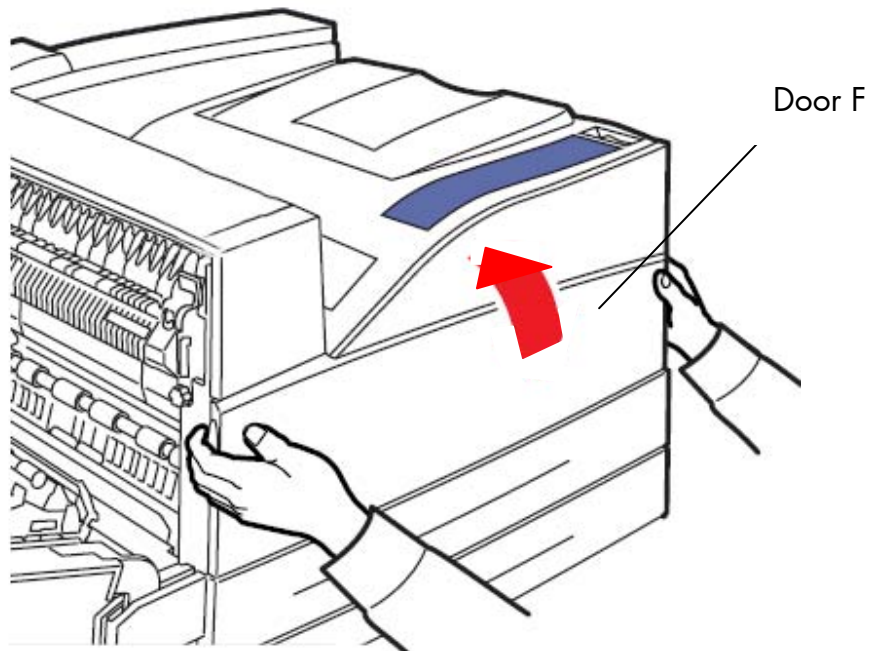

Fig. 2.3.n Closing the printers front door (door F)

2.4. Printer Installation

- The chosen location should be clean, dry and well-ventilated.
- Damaging environmental factors such as metal vapors, oil mist, corrosive leaches or the like must not affect the printer.



- Place the printer on a horizontal, firm and solid surface.
- The printer environment has to be free of shocks or vibrations.



- The printer and socket have to be easily accessible.
- The printer should not be located near volatile or combustible materials (e.g. a curtain).



- To avoid damage, the devices must be switched off (e.g. cut off from the power supply) before the user begins connecting the interface lines.



- The printer must be connected to an appropriate AC power source 120V AC/60 Hz (North America) or 230V/50 Hz (Europe, United Kingdom e.g.). The power source must be properly grounded. The socket and power cords must not be damaged.
- Use the printer only within the allowed fluctuation range of $\pm 10\%$.
- The power source must be free of noise, and not subjected to surges or noise (e.g. generated by big machines).



If you're going to move or transport the printer, keep the following in mind:

- Because the printer is heavy (approximately 48 kg [106 lbs]), two people are required to lift it safely.
- Remove the toner cartridge and the drum cartridge before you move or transport the printer!
If the printer is moved with the two cartridges installed, toner may spill out and damage the printer.
- Be sure to plug the printer into a properly grounded outlet in the new location.

- Please note the following environment conditions are needed to operate the printer at full capacity:

Temperature: +5°C (41°F) to +32°C (90°F)

Relative atmospheric humidity: 15% to 85%



- Do not expose the printer to abrupt temperature changes (heating, window or air conditioning).

- The printer should not be exposed to direct sunlight.

- Required space:

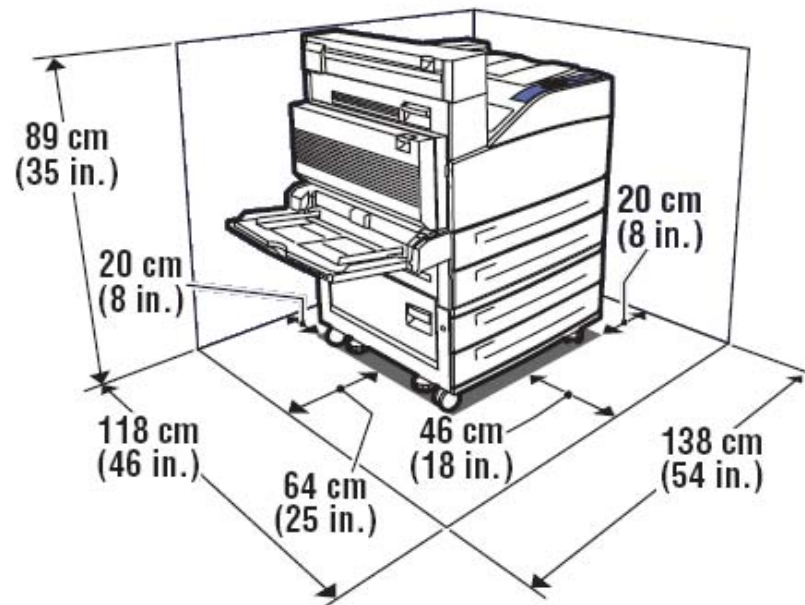

Fig. 2.4.a Required space for the SOLID 50 A3 - 3 (printer with optional cassette 3+4)

- Required space (continuation):

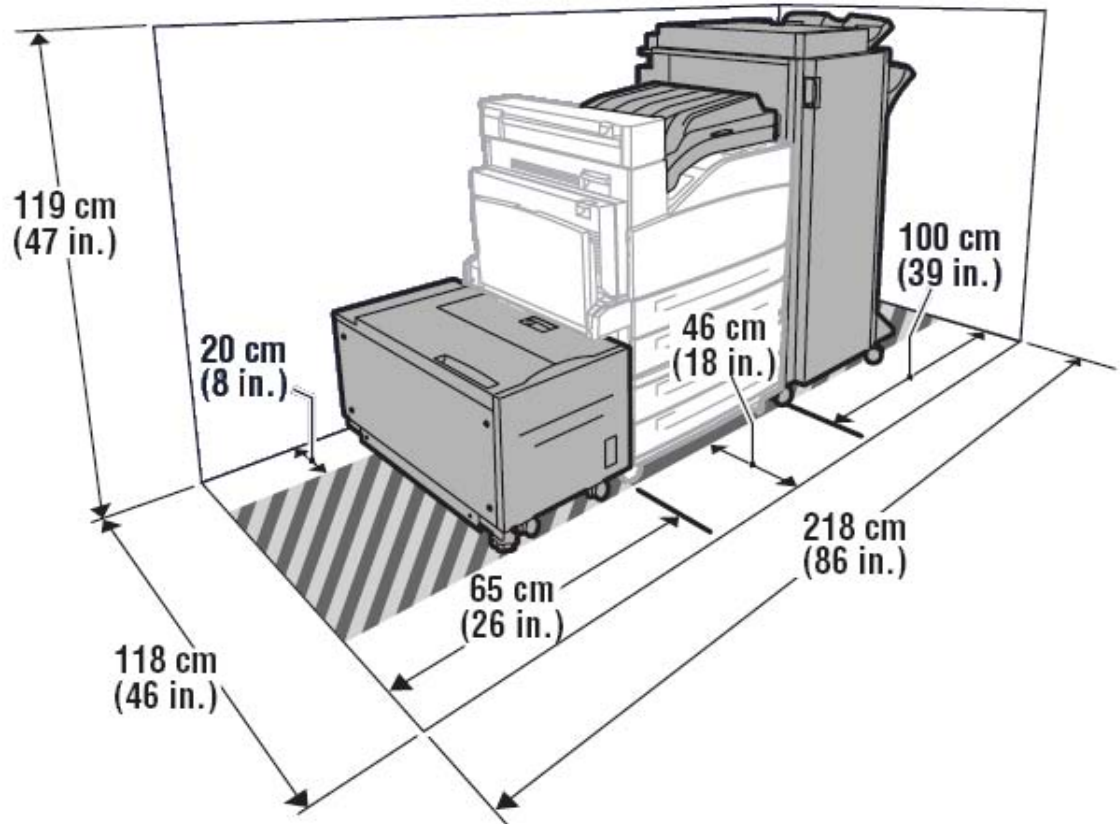

Fig. 2.4.b Required space for a printer SOLID 50 A3 - 3 with options

- in this example: Printer equipped with a high capacity feeder and a finisher /stacker

2.5. Printer Components

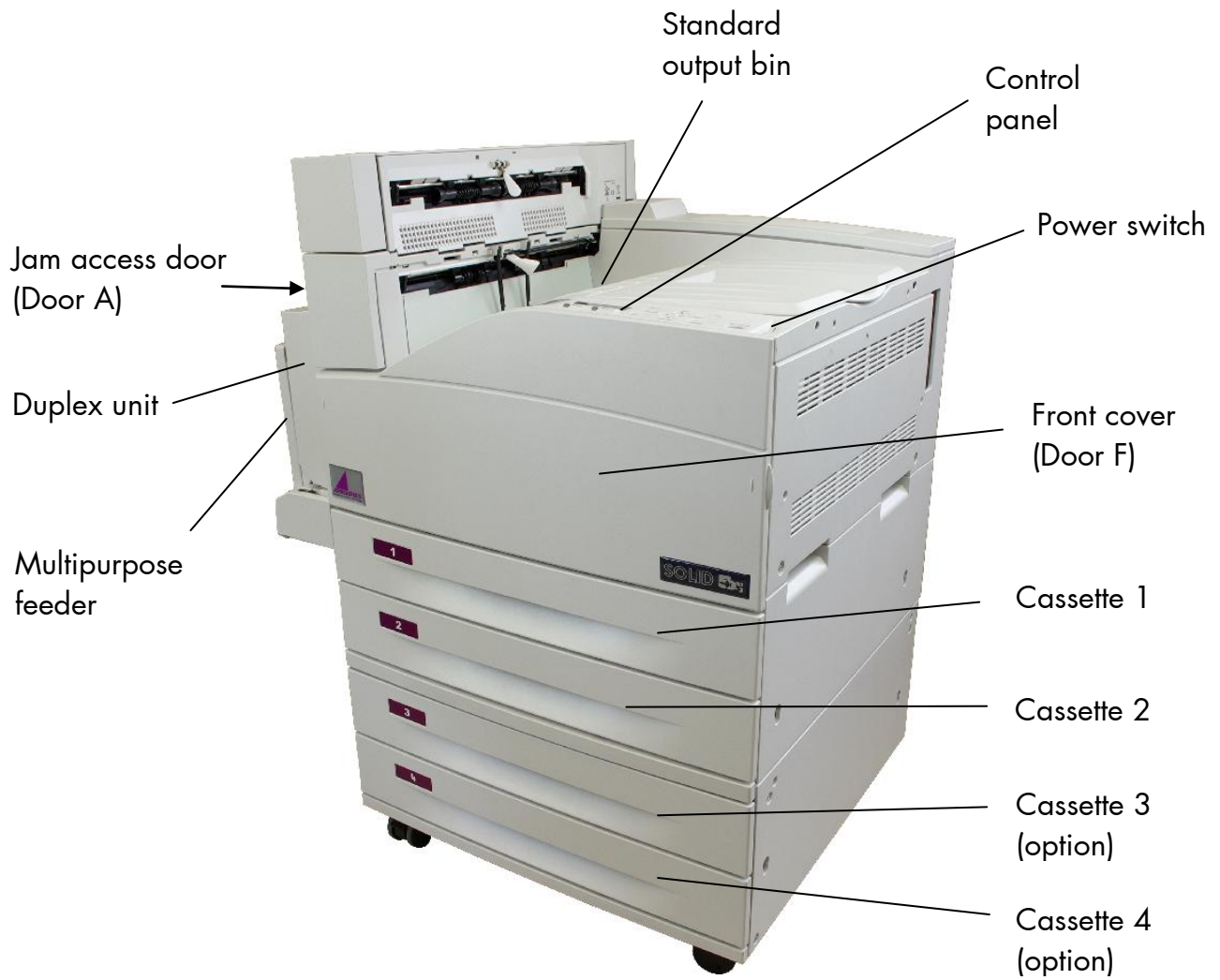

Fig. 2.5.a Printer Components

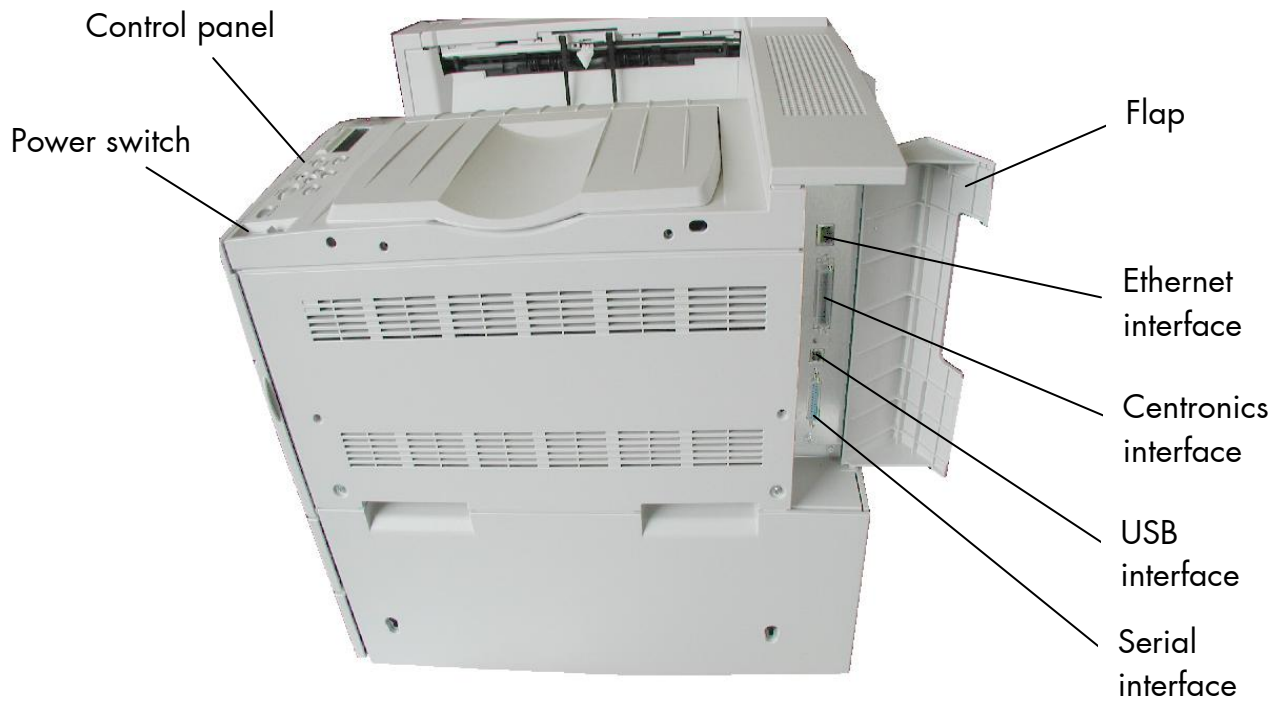

Fig. 2.5.b View on the interfaces

3. Handling of Consumables

3.1. Print Media Handling (Paper, e.g.)



The printer processes the sizes A3, A4, A4R, A5, A5R, Ledger, Letter, LetterR and Legal (see table in section 3.1.4) with paper weights from 64 to 163 g/m².



Paper jams can be avoided by accurately and carefully filling the paper cassettes. Please do not open or remove a paper cassette while the printer is running.

Please notice the specifications about the paper's "print-side" (see the information on the paper packing).

If an empty paper cassette has to be refilled (without changing the paper size, compare section 3.1.4) do the following:

3.1.1. Loading Cassettes 1 and 2

Your SOLID 50 A3 - 3 has two standard cassettes (cassettes 1 and 2). They can each hold 500 sheets of plain paper.

1. Pull the cassette open until it stops.

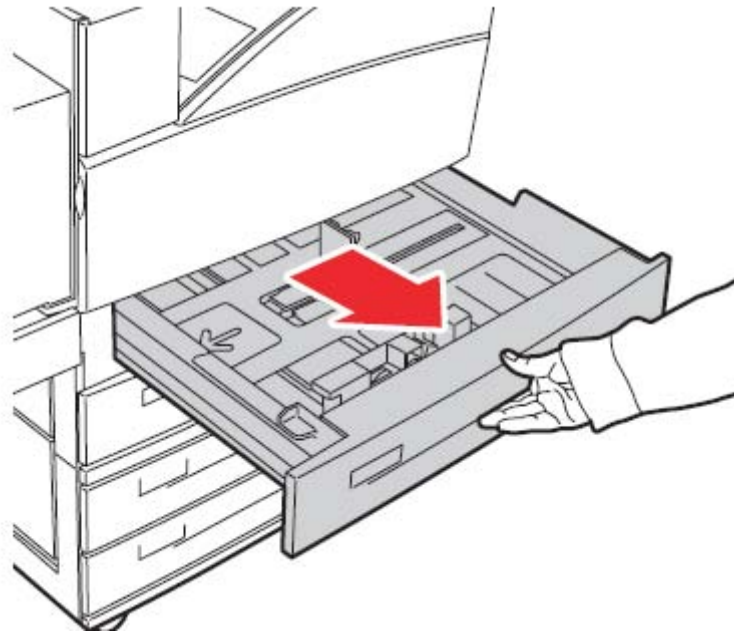

Fig. 3.1.1.a Opening the cassette

2. Press the levers of the side guide (compare the small “picture” in the upper part of the following figure) and move the side guide to the right.

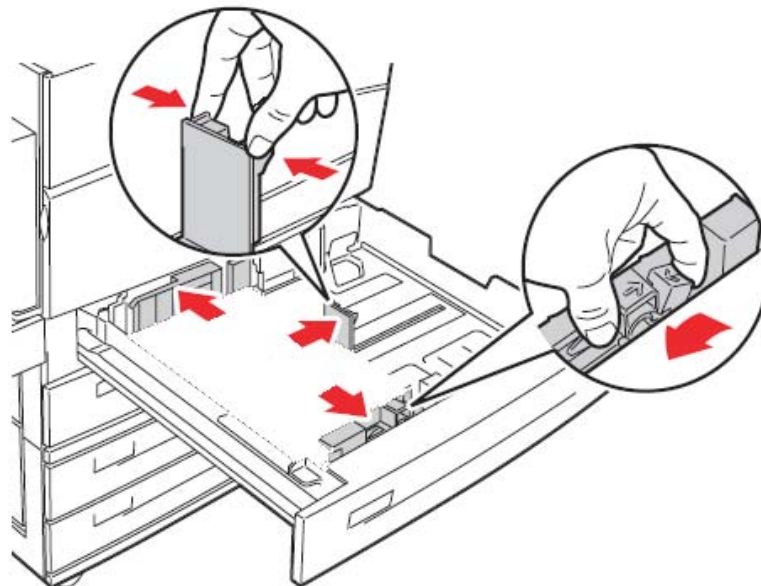

Fig. 3.1.1.b Moving the paper guides

3. Press the levers of the front guide (compare the small “picture” in

the right part of the figure above) and slide this guide to the front side of the cassette.

Note: You'll find labels with print media size information in the cassettes.

4. Flex the sheets back and forth to loosen them, and then fan them. Do not fold or crease the print media.

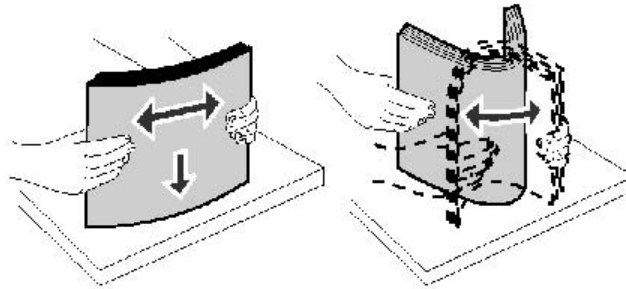

Fig. 3.1.1.c Fanning and aligning the paper pile

5. Straighten the edges of the stack on a level surface.
6. Now put your stack of print media into the cassette as shown in the following figure.

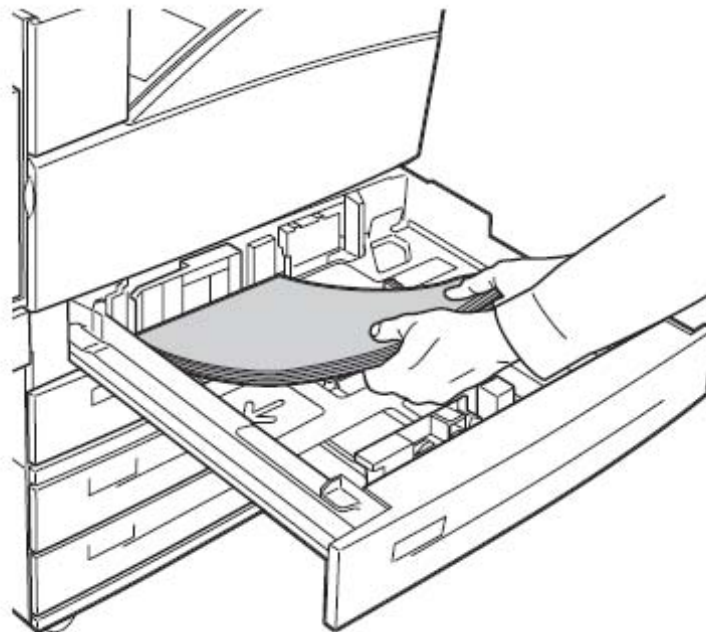

Fig. 3.1.1.d Inserting print media



Do not exceed the maximum stack height indicated on the back guide. Overfilling the cassette may cause paper jams.

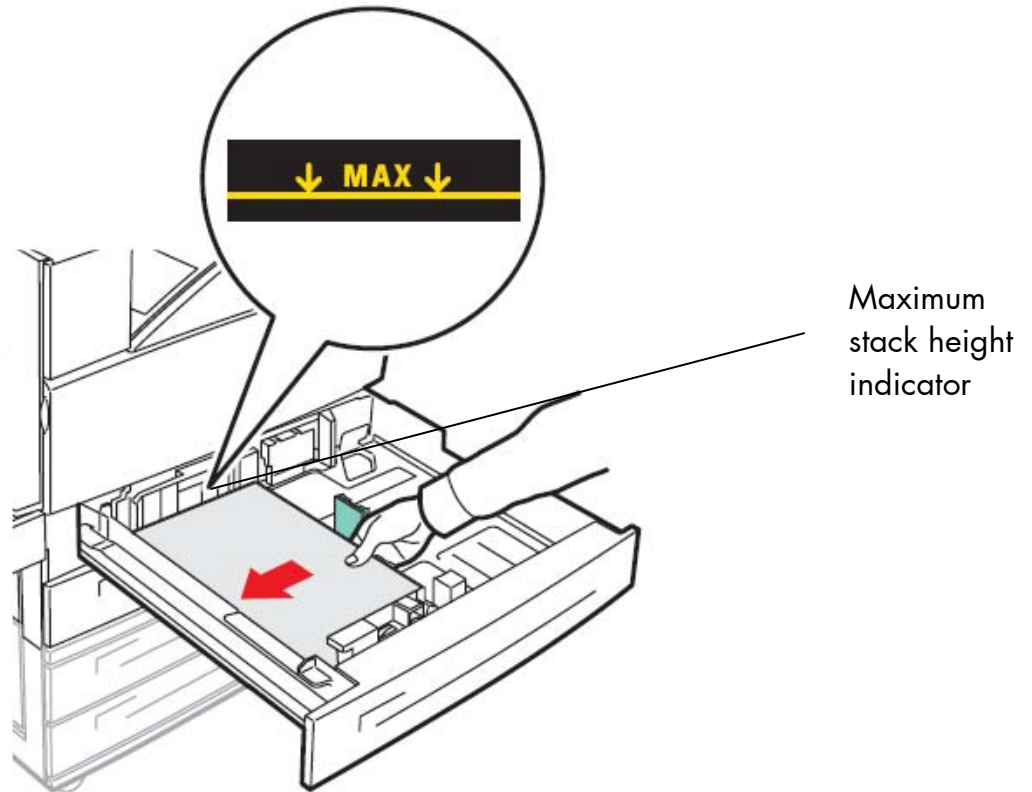

Fig. 3.1.1.e Filling level for the cassette



Do not load bent or wrinkled print media.

7. Press the levers of the front guide (see next figure) and slide the guide until it lightly touches the stack of print media.

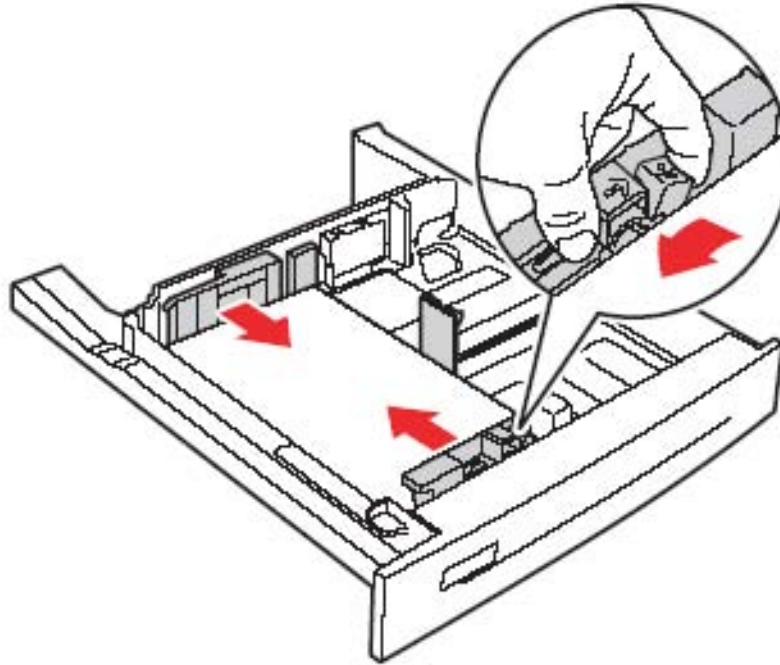

Fig. 3.1.1.f Sliding the front guide to the print media stack

8. Press the levers of the side guide and slide it to the left until it lightly touches the stack of print media. Make sure the guide locks into place.

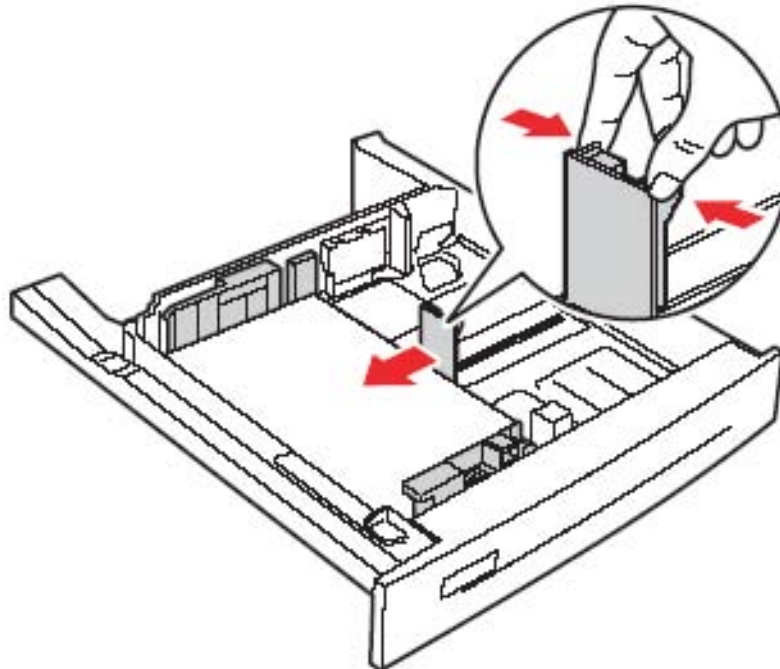

Fig. 3.1.1.g Sliding the side guide to the print media stack

- Slide the cassette all the way into the printer. If the cassette is not pushed completely into the printer, text and images may print in the wrong position on the page, and the margins may appear incorrect, or you may receive an error message.

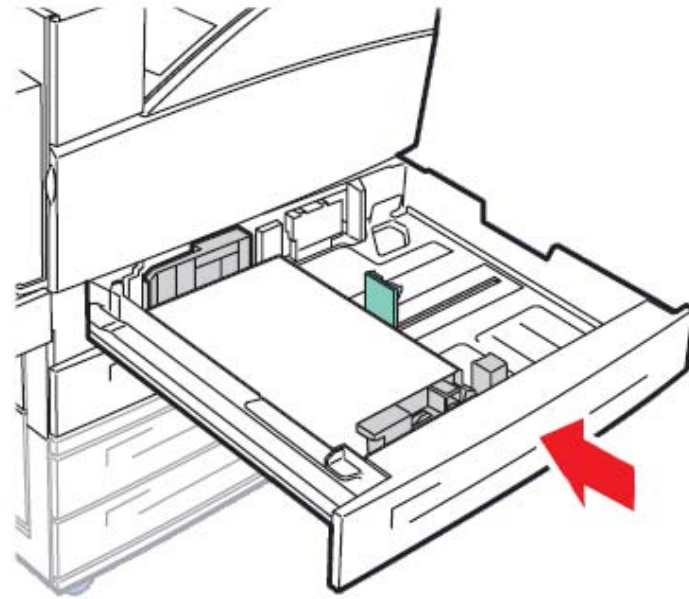

Fig. 3.1.1.h Sliding the cassette into the printer

3.1.2. Loading the Multipurpose Feeder

The multipurpose feeder comes standard with the printer and holds approximately 100 sheets of 20 lb paper.

1. Open the multipurpose feeder.

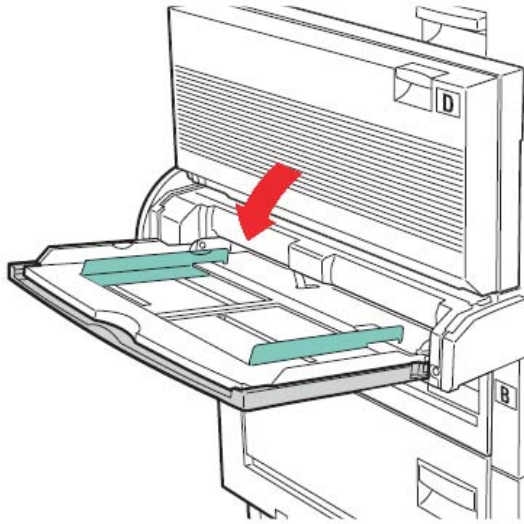

Fig. 3.1.2.a Opening the multipurpose feeder

2. "Open" the paper guides for the print media to be used. (Slide the paper guides to the edges of the multipurpose feeder.)
3. Adjust the extension guide to the length of the print media to be used.
4. Flex the sheets back and forth to loosen them, and then fan them.

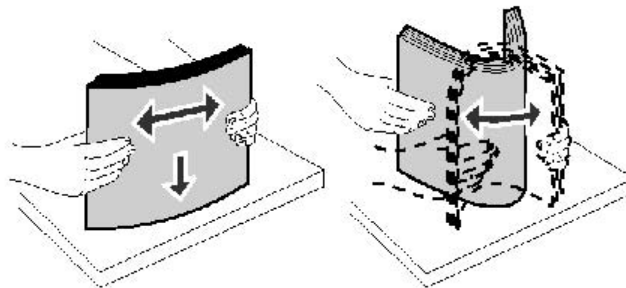

Fig. 3.1.2.b Fanning and aligning the paper pile

5. Straighten the edges of the stack on a level surface.



Do not load bent or wrinkled print media.

6. Orient the stack of print media correctly for the size, type, and print method you are using. Refer to the icons on the feeder.



Do not exceed the maximum stack height indicated on the paper guide. Overfilling the feeder may cause paper jams.

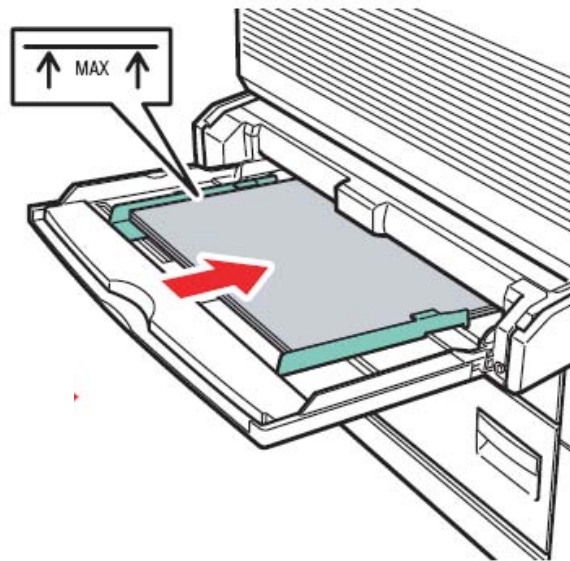

Fig. 3.1.2.c Mark for the maximum stack height

7. Place the print media along the front side of the multipurpose feeder and push it in as far as it will go.

Do not force the print media.

8. Slide the guides towards the stack (see the following figure) until they lightly touch the stack of print media.

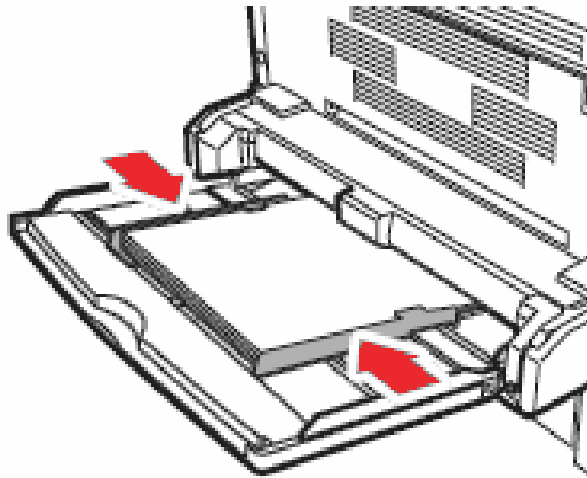

Fig. 3.1.2.d Sliding the guides to the print media stack

9. When finished printing from the multipurpose feeder, remove any print media, push the extension guide back in, and push the feeder to the closed position.

3.1.3. Using the Output Bins

The printer has one standard bin, which holds up to 500 sheets of print media that exit face down.



Fig. 3.1.3.a Standard output bin of the printer

As an option a 3,500 sheets finisher/stacker and a face-up stacker (100 sheets) are available for your SOLID 50 A3 – 2 printer.

3.1.4. Changing the Paper Size Setting

Depending on the print material you use, you may need to change the Paper Size setting.

The following table shows the paper sizes supported by the paper cassettes:

Cassette / Feeder	Paper sizes supported									Print media supported	Capacity
	A3	A4	A4R	A5 *1)	A5R *2)	Ledge	Letter	LetterR	Legal		
Multipurpose feeder	Yes	Yes	Yes	Yes	Yes	Yes	Yes	Yes	Yes	Paper, transparencies, labels, card stock	appr. 100 sheets of 20 lb paper
1	Yes	Yes	Yes	Yes	Yes	Yes	Yes	Yes	Yes	Paper, transparencies	500 Sheets of 20 lb paper
2	Yes	Yes	Yes	No	Yes	Yes	Yes	Yes	Yes		500+500 Sheets
3 and 4 (2 TT)	Yes	Yes	Yes	No	Yes	Yes	Yes	Yes	Yes		1200+800 Sheets
3 and 4 (Tandem TT)	No	Yes	No	No	No	No	Yes	No	No		

*1)

A5 = Long Edge Feed

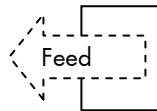

*2)

A5R = Short Edge Feed

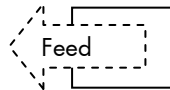

To change the size of the print page (print image) use the panel function **Paper Size Selection** (see section 5.12).

The printer is able recognize the paper size of the print media in the paper feeders (cassettes). The printer automatically detects the positions of the paper guides for this.



Please set the paper guides of the feeders (cassettes) to the exact size of your paper (notice the markings).

Further information can be found in section 3.1.1 Loading Paper to the Printer Cassettes.

You can use the **panel function Enabling Format Check** (see section 5.13) to enable or disable automatic format check of the printer.

If there is no paper with appropriate size in any paper cassette, an error message like the following example is displayed on the panel:

```
[Format Error   ]
[DIN A5 missing ]
```



Non Standard paper sizes (user defined formats) have to be set using the panel functions Page Length and Paper Width (compare section 4.6 Menu structure).

3.2. Toner Cartridge Replacing

Replace the toner cartridge as soon as the message [Toner empty!] is displayed.

On average 30,000 letter-size pages can be printed with one toner cartridge. (This depends on the print density. In this example, a print density of 5% was considered).

Warning: We do not recommend refilling used toner cartridges or purchasing refilled cartridges from a third party. Print quality and printer reliability cannot be guaranteed if you do. The printer warranty does not cover damage caused by using refilled cartridges.



Please store the toner cartridge in its original packing until it is installed.

Extreme fluctuations of atmospheric humidity and/or temperature are not allowed.

The values listed in section 2.4 need to be met.

In order to replace the toner cartridge, follow these instructions:



Notice the information used with the toner cartridge also.

1. Switch off the printer.
2. Pull up on the handle to open the printer side door (Door A). Gently lower the door to the open position.

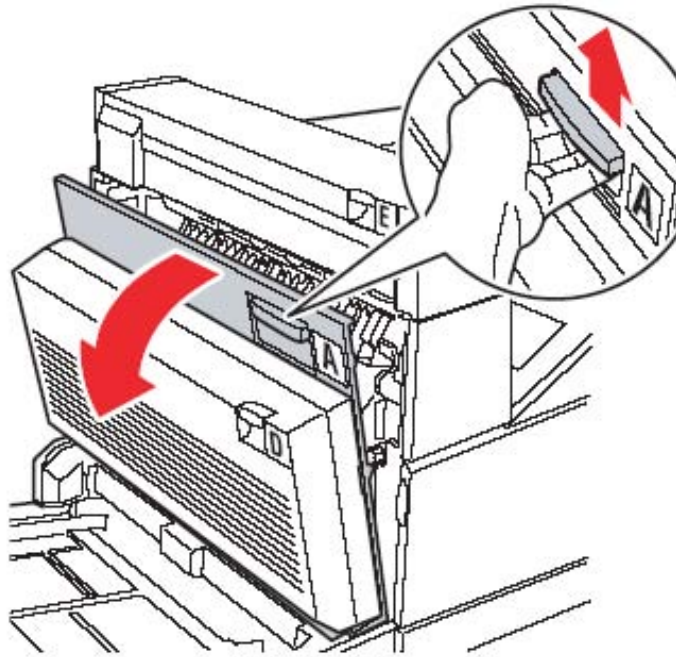

Fig. 3.2.a Opening the side door (door A)

3. Using the handholds located on each side, pull open the printer front door (Door F).

Note: You must open the printer side door since the toner cartridge cannot be removed with just the printer front door opened.

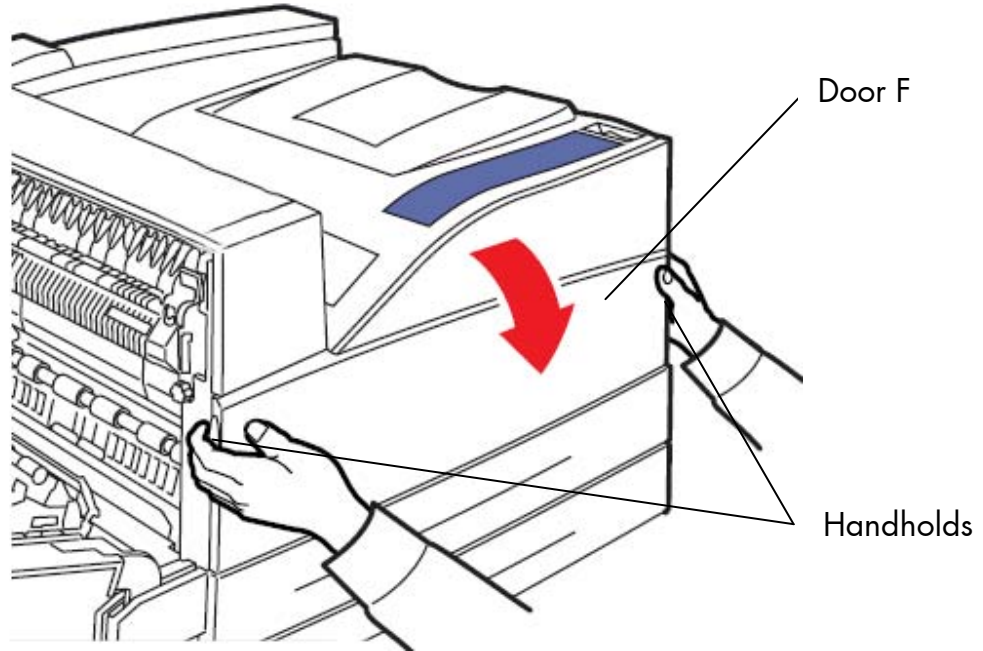

Fig. 3.2.b Opening printer's front door (door F)

4. Pull up on the latch to release and slide the toner cartridge out until you see the handle.

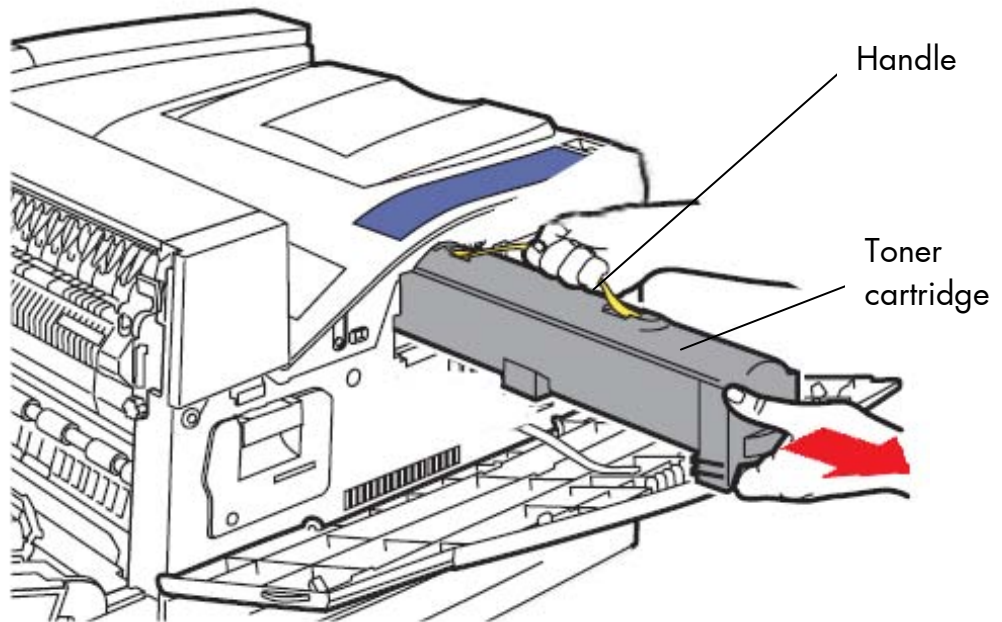

Fig. 3.2.c Taking out the toner cartridge

5. Use the handle to pull the old toner cartridge straight out, and place it on a suitable site.



6. Clean the printer (see chapter 6).

7. Take the new toner cartridge out of its packing.

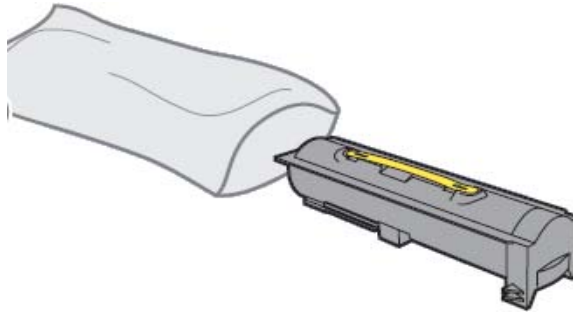

Fig. 3.2.d Taking the new toner cartridge out of its packing

8. Turn the cartridge so that the handle is on top.

9. Shake the cartridge vigorously in all directions (as shown in figure 3.2.e) to distribute the toner.



If toner spills on the floor, do not clean it up using a vacuum or a wet cloth. Wipe up the spill with a dry cloth. If toner gets on clothing, be sure to wash the clothing in cold water.

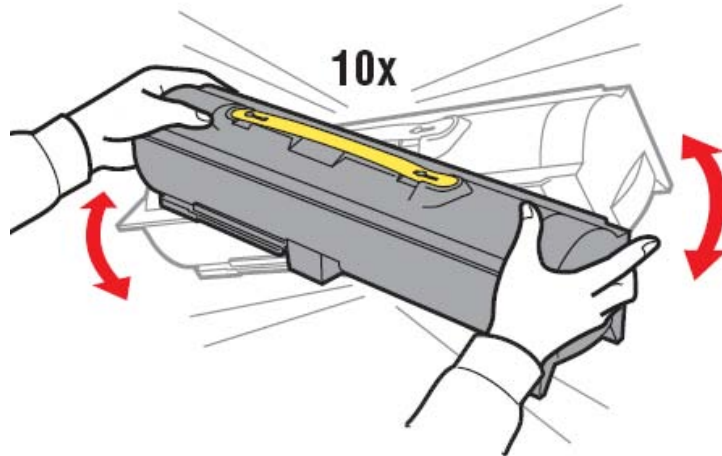

Fig. 3.2.e Shaking the toner cartridge

10. Holding the new toner cartridge by the handle and one end, align the cartridge with the slots inside the printer and slide the toner cartridge halfway in.

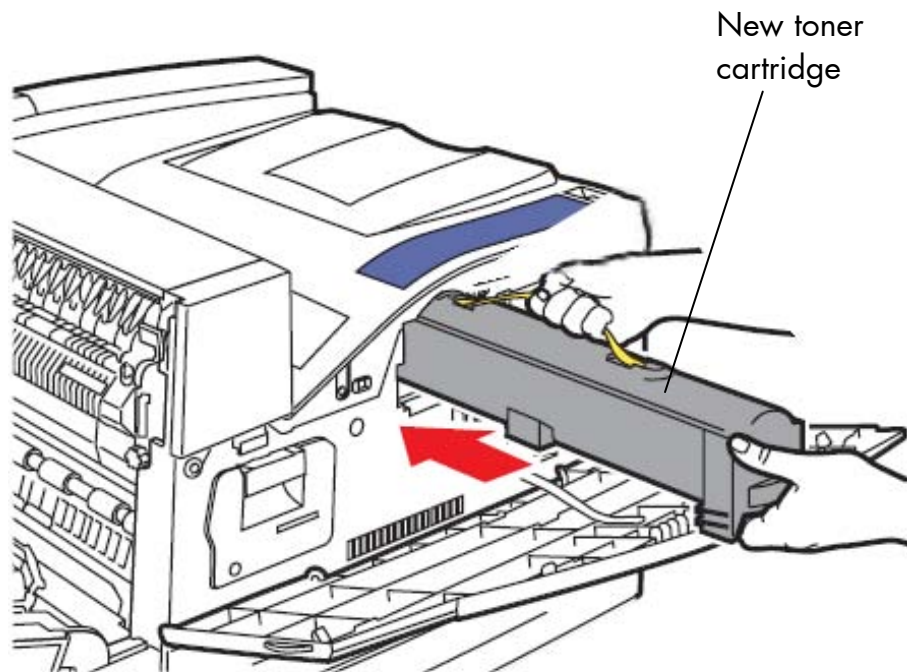

Fig. 3.2.f Inserting the guides of the new toner cartridge

11. Push the toner cartridge into the printer until the cartridge clicks into place.



Fig. 3.2.g Inserting the new toner cartridge

12. Close the printer side door (Door A).
13. Hold both sides of the printer front door (Door F) and close it.
14. Place the used toner cartridge in the plastic bag you saved in step 7.

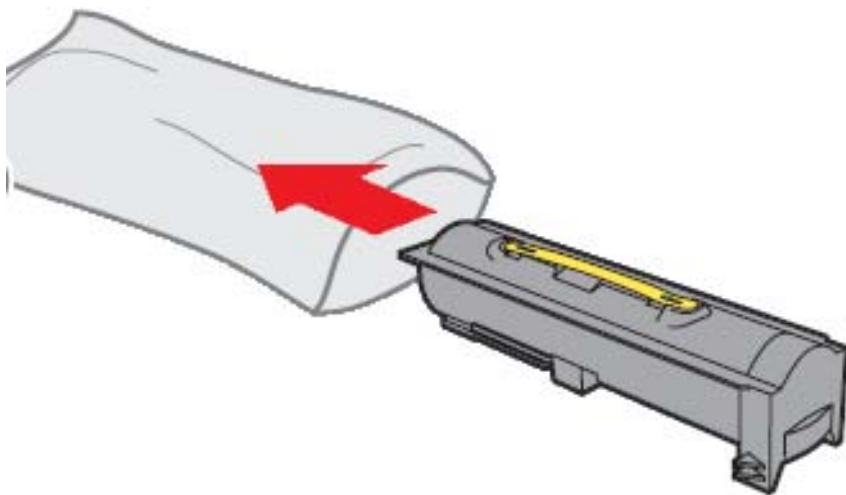

Fig. 3.2.h Use the plastic bag for the old toner cartridge

15. Please pay attention to the information about the disposal of the old toner cartridge (current information can be found on the new toner cartridge).

By returning the used toner cartridge to MICROPLEX, you help support world-wide recycling efforts. Until disposal, keep the old toner cartridge inside a closed cardboard box.

3.3. Drum Cartridge Replacing

On average 60,000 letter-size pages can be printed with one drum cartridge.



Please store the drum cartridge in its original packing until it is installed.

Extreme fluctuations of atmospheric humidity and/or temperature are not allowed.

The values listed in section 2.4 need to be met.

In order to replace the drum cartridge, follow these instructions:



Notice the information used with the drum cartridge also.

1. Switch off the printer.
2. Pull up on the handle to open the printer side door (Door A).
3. Gently lower the door to the open position.

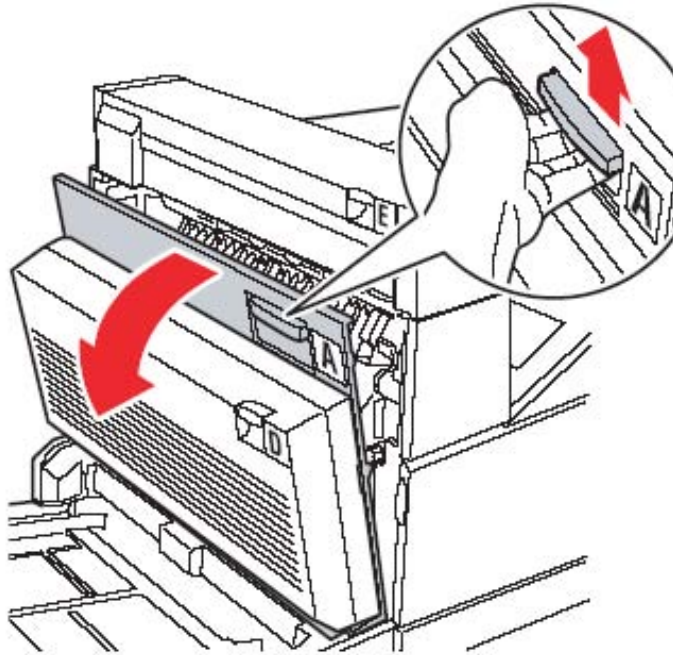

Fig. 3.3.a Opening the side door (door A)

4. Using the handholds located on each side, pull open the printer front door (Door F).

Note: You must open the printer side door since the drum cartridge cannot be removed with just the printer front door opened.

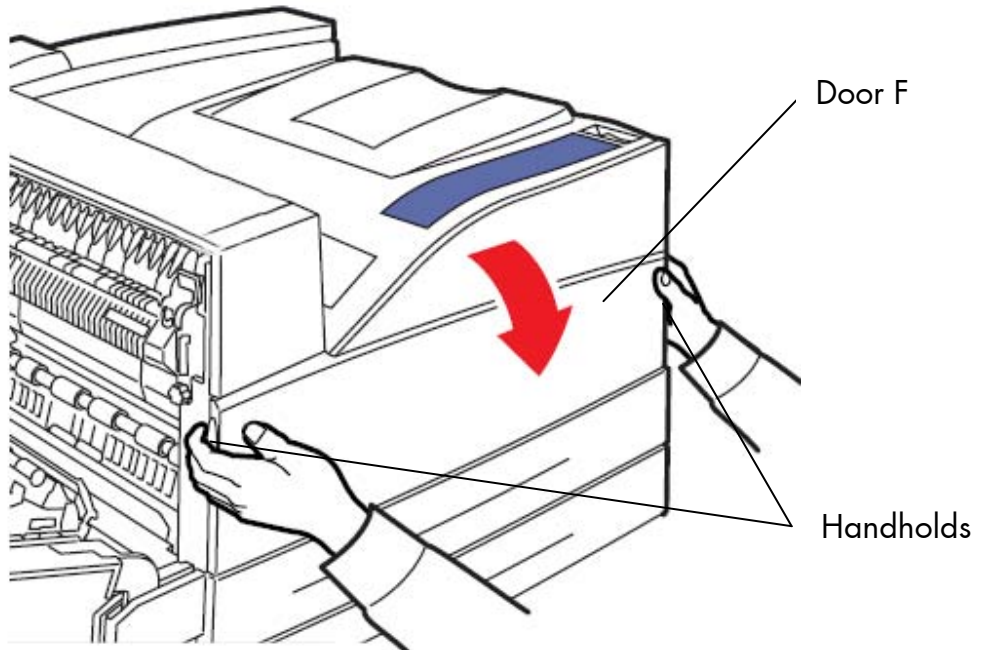

Fig. 3.3.b Opening the printer's front door (door F)

5. Pull up on the latch to release and slide the drum cartridge out until you see the handle.

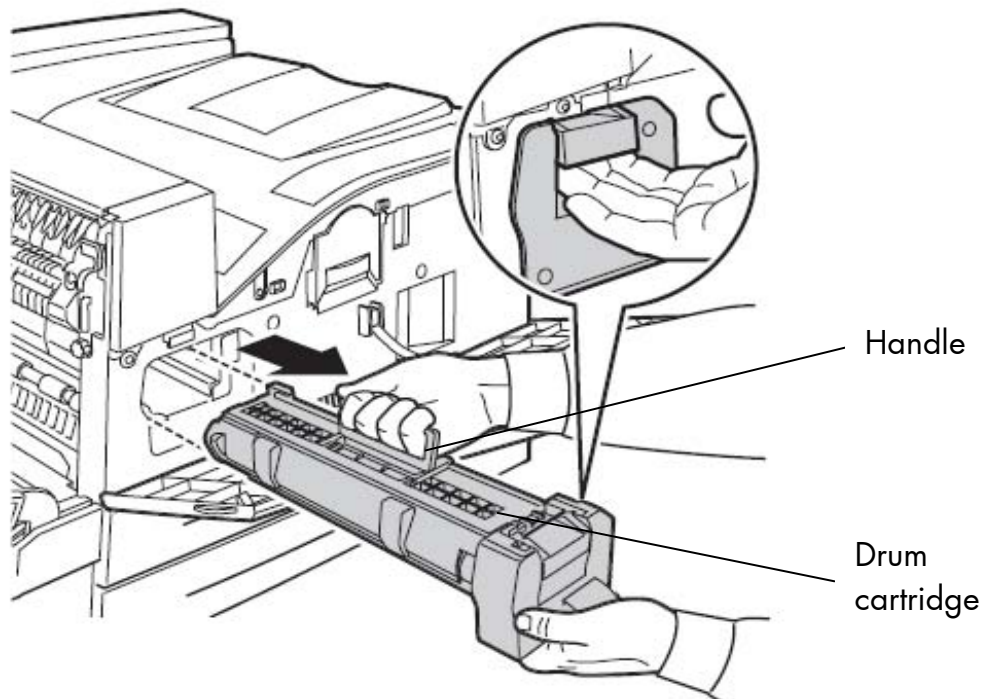

Fig. 3.3.c Taking out the drum cartridge

6. Use the handle to pull the drum cartridge straight out, and place it on a suitable site.
7. Clean the printer (see chapter 6).
8. Take the new drum cartridge out of its packing and place it in an acceptable atmosphere. Save the plastic bag.



Do not remove the yellow tape from the drum cartridge at this point. This has to be done in step 14.

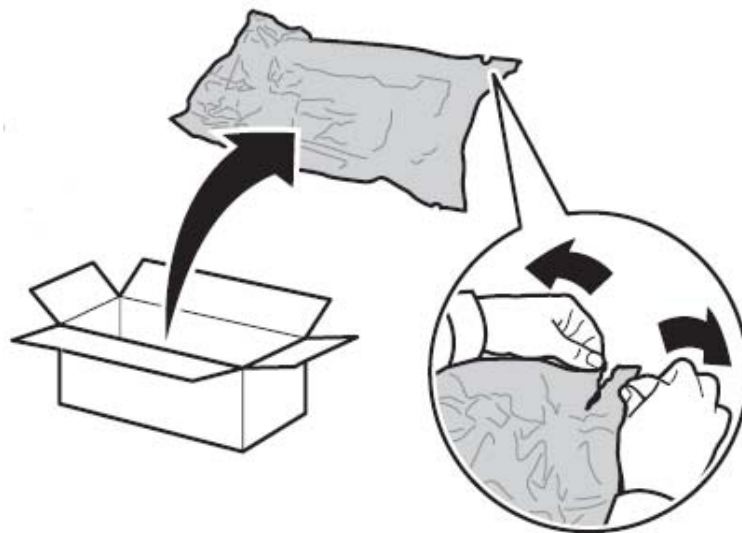

Fig. 3.3.d Unpacking the new drum cartridge

9. Turn the cartridge so that the handle is on top.
10. Remove the tape (on the top of the cartridge; see the following figure) and then gently pull the protective paper straight up and out of the cartridge.

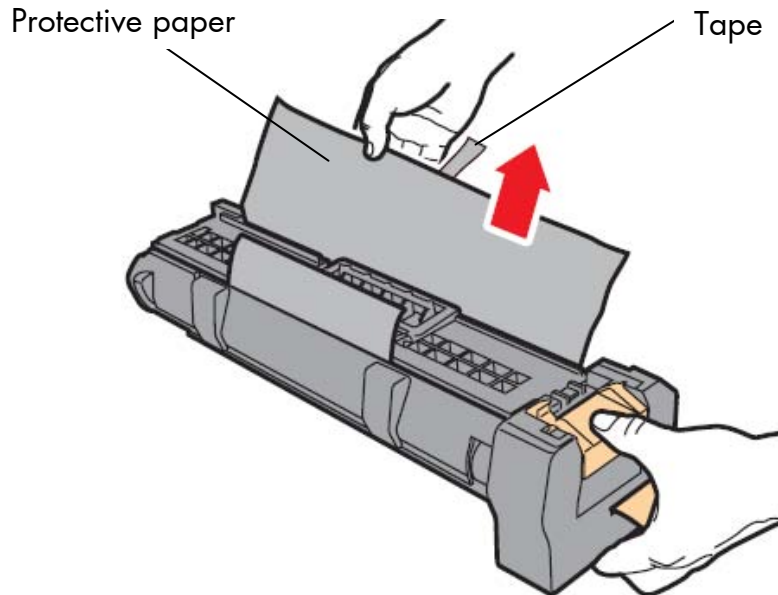

Fig. 3.3.e Removing the protective paper of the new drum cartridge



Do not leave the drum cartridge exposed to light for extended periods of time.

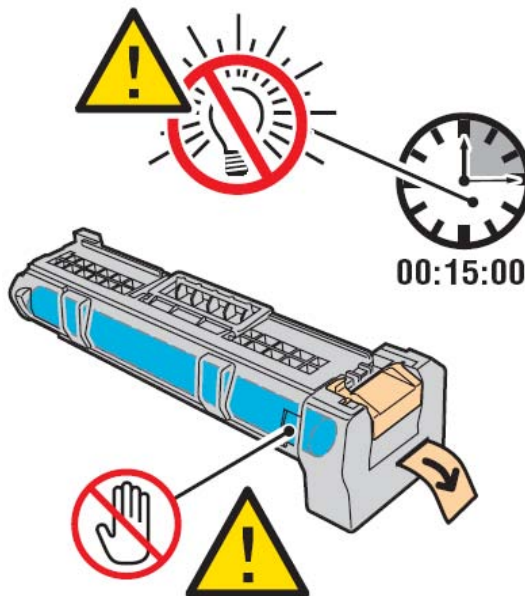

Fig. 3.3.f Hints about the drum cartridge

11. Holding the new drum cartridge by the handle and one end, align the cartridge with the slots inside the printer and slide the drum cartridge halfway in.

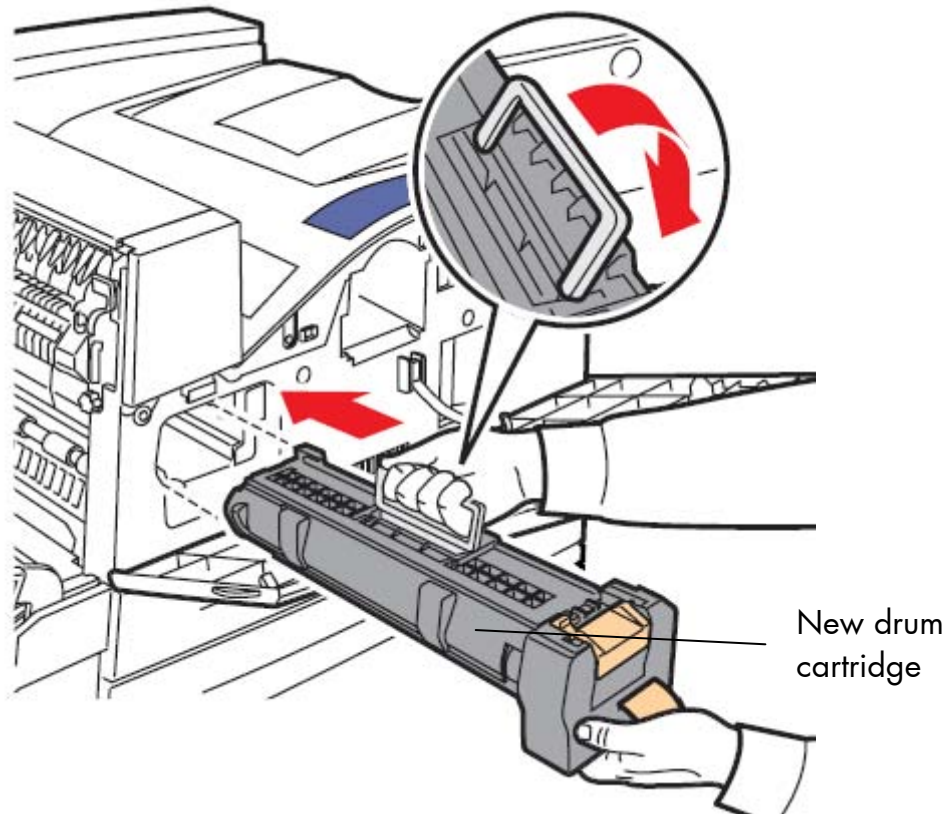

Fig. 3.3.g Inserting the guides of the new drum cartridge

12. Drop the handle back into place.
13. Push the drum cartridge into the printer until the cartridge clicks into place.

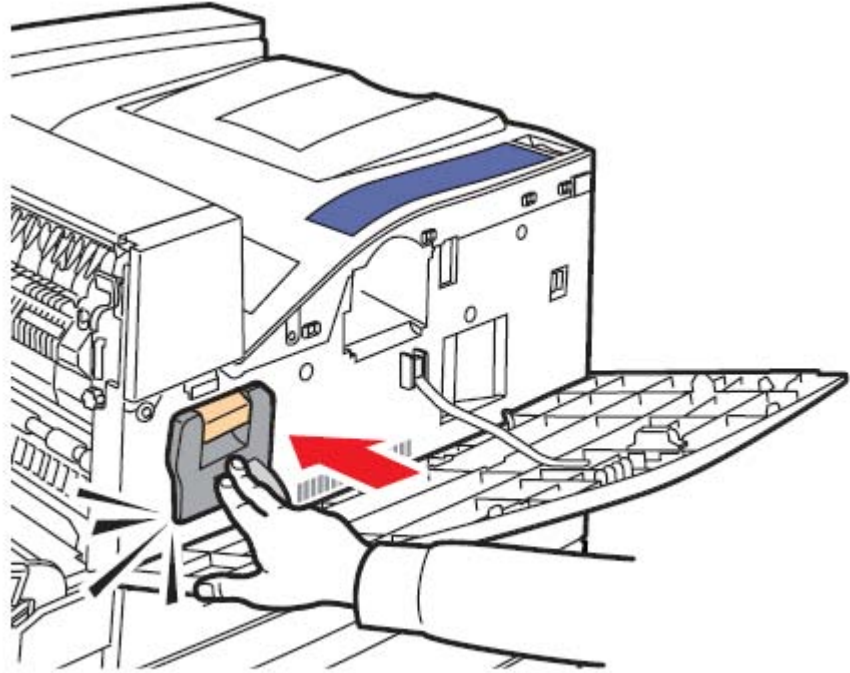

Fig. 3.3.h Inserting the new drum cartridge

14. Carefully pull the yellow tape completely out of the cartridge.
Discard the tape.

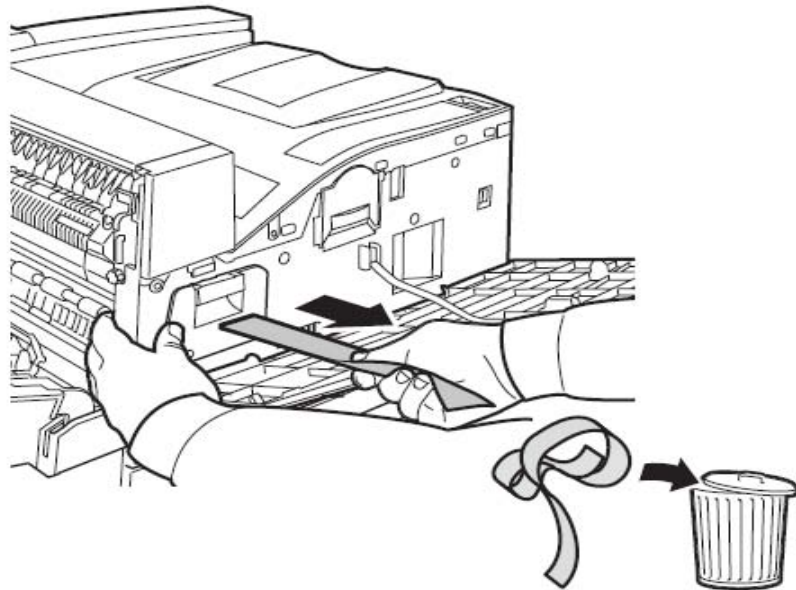

Fig. 3.3.i Removing the yellow tape

15. Close the printer side door (Door A).

16. Hold both sides of the printer front door (Door F) and close it.

17. Place the used drum cartridge in the plastic bag you saved in step 9.

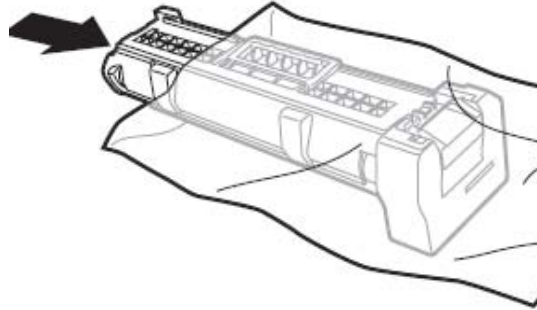

Fig. 3.3.j Use the plastic bag for the old drum cartridge

18. Please pay attention to the information about the disposal of the old drum cartridge (current information can be found on the new drum cartridge).

By returning the used drum cartridge to MICROPLEX, you help support world-wide recycling efforts. Until disposal, keep the old drum cartridge inside a closed cardboard box.

4. Operation and Menu Structure

4.1. Attaching the Printer to a Computer

1. Make sure the printer, computer, and any other attached devices are turned off and unplugged.
2. Use a proper interface line to connect the printer to the computer or to attach the printer to the network.
The printer SOLID 50 A3 - 3 is provided with several interfaces; see figure 2.5.b and chapter 9 Specifications for more information.

4.2. Turning on the Printer

1. Plug one end of the printer power cord into the socket at the back of the printer and the other end into a properly grounded outlet.



Fig. 4.2.a Connect Power



Fig. 4.2.b Turning on the printer

2. Turn on the printer.

The printer requires time to warm up after you turn it on. During this period, the message **[Please Wait]** appears on the control panel display. After the printer completes its internal tests, the **[SOLID 50 A3 - 3]** message indicates the printer is ready to receive jobs. If you see other messages on the display, refer to chapter Troubleshooting for instructions on clearing the message.

Note: You can change the language that appears on the control panel display. Use the "Display Language Selection" panel function (see section 5.17).

4.3. Control Panel View

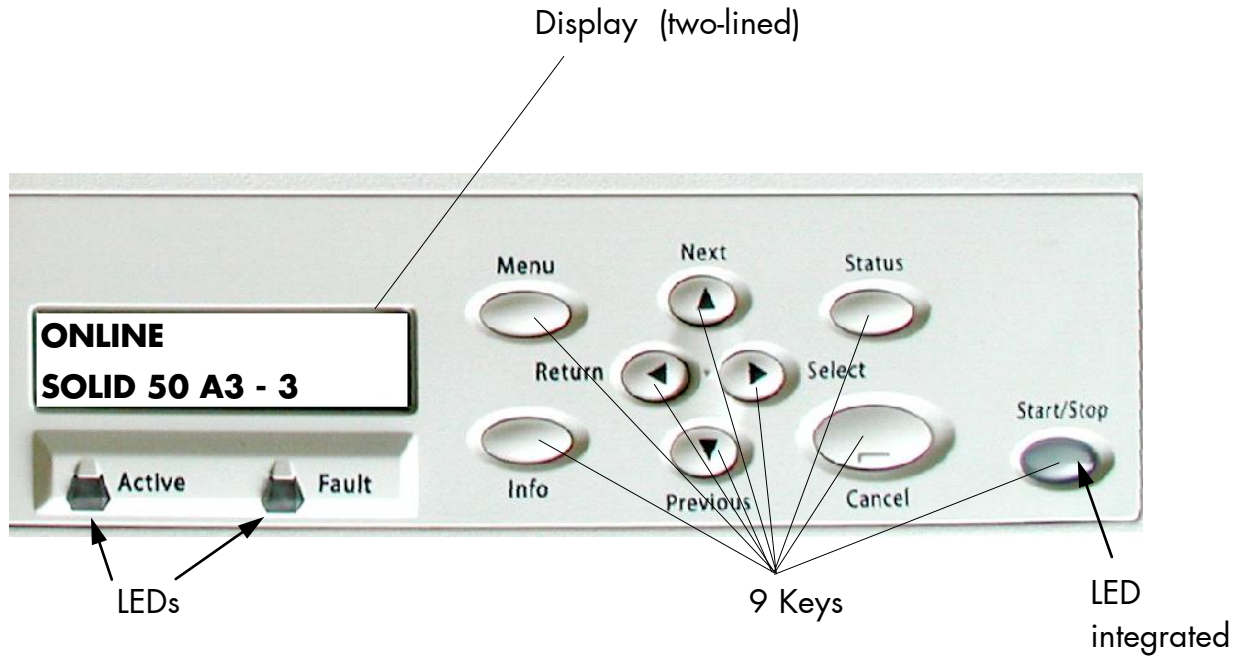

4.4. Function of the Control Panel Elements

Display

The display (panel) serves to show the printer's status messages.

ON LINE - LED (integrated in the **START/STOP key**)

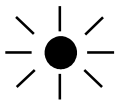

The printer is ready to receive data from the host (the printer is ON LINE).



The printer is not ready to receive data from the host (OFF LINE). The control panel keys are active.

DATA - LED

ACTIVE

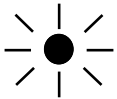

The printer receives printable data.



The printer's input buffer contains printable data and the controller waits for further data.



There are no printable data in the input buffer.

ERROR - LED

FAULT

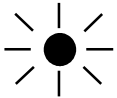

An error occurred in the printer. The printer is OFF LINE.



No error occurring.

Panel keys



This key is used to start the printing of a status sheet. (As an alternative the panel function Printing the Status Sheet can be used).

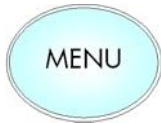

The MENU key is used to get into the next (higher) level of the menu structure. As an alternative the RETURN key can be used as well.

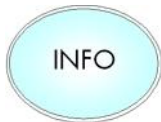

Using this key confirms inputs and releases functions. As an alternative the SELECT key can be used as well.



The START/STOP key turns the printer ON- / OFF LINE.



These keys are used for working within the different levels of the menu structure. This structure and the panel functions are described in the following.

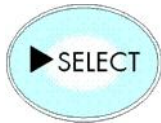

Using this key a RESET is released in the OFF LINE mode. You can back out e.g. error messages by a RESET.

4.5. Configuration via the Control Panel

You can use the control panel to change the printer configuration and customize your printer to meet your specific needs.

In addition printer configuration via Ethernet is possible. The MICROPLEX printer controller offers an integrated website, for more information see [Networking Features of MICROPLEX Printers](#).

Chapter 5 (Panel Functions) describes how to reach the particular printer functions via the control panel.

T e m p o r a r y changes in printer configuration are effective only as long as the printer stays turned on. To select such changes temporarily, the user must terminate the change of function by pressing the **SELECT*** **key** one single time.

P e r m a n e n t changes in printer configuration are active each time the printer is turned on again. To select such changes permanently, the user must terminate the change of function by pressing the **SELECT*** **key two times**.

An output of the current printer values can be generated using the panel function "Printing the Status Sheet " (see section 5.1).

Please note:

- User default settings remain in effect until you save new settings or restore the factory defaults.
- Settings you choose from your software application or printer driver can also change or override the user default settings you select from the operator panel.

* As an alternative the key INFO can be used as well.

4.6. Menu Structure

Access to the menu structure is possible as soon as the printer is turned OFF LINE. The menu structure of the SOLID 50 A3 - 3 is arranged in different levels:

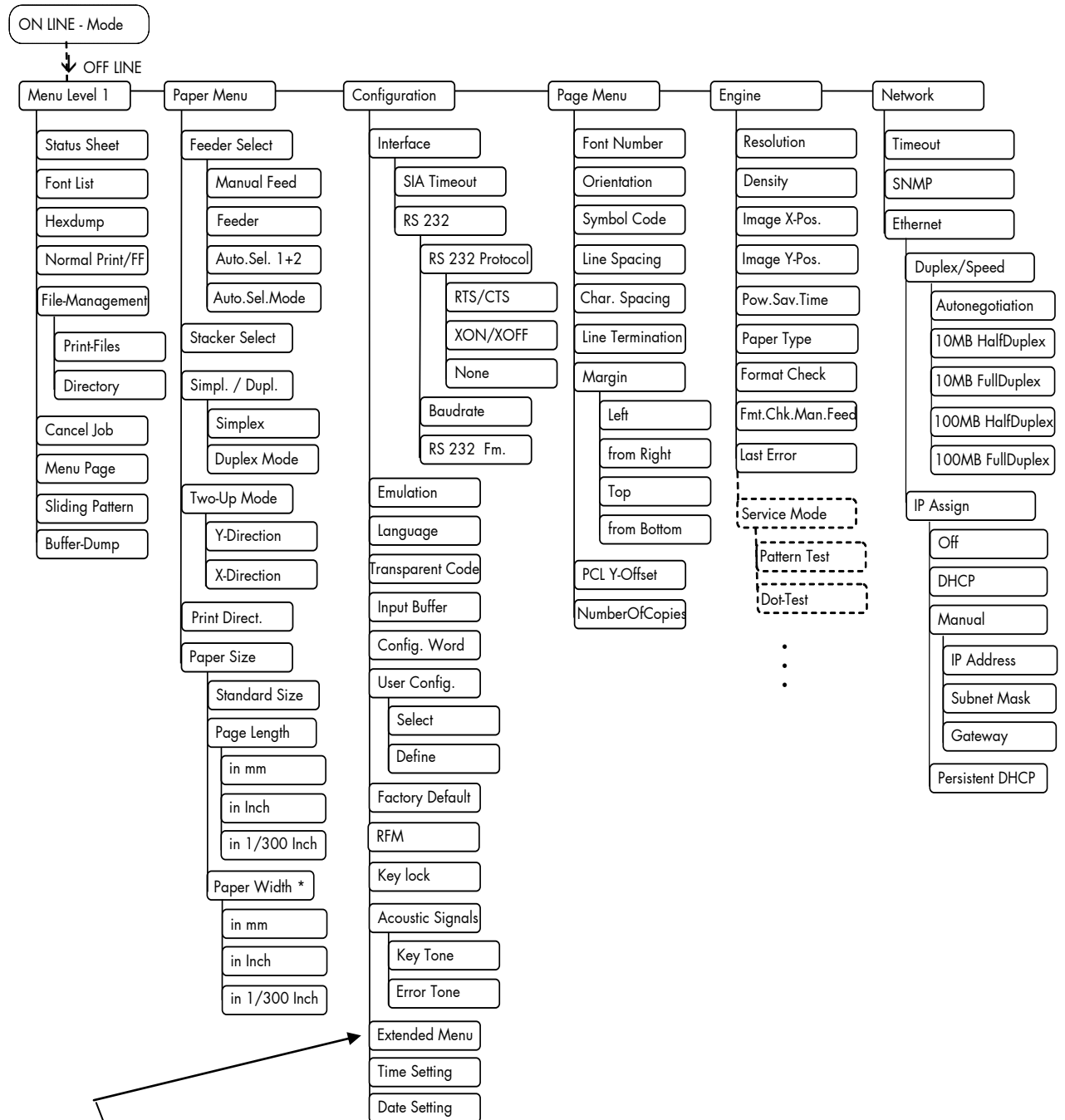

This panel function allows the user to choose a **reduced menu** instead of the extended menu shown above.

Selecting positions in the menu structure:



This symbol shows the START/STOP key. You get automatically into menu level 1, if the printer is turned OFF LINE with this key.



By pressing the NEXT key or the PREVIOUS key you can move within the menu levels.

["Menu Level"]

Each menu item/subitem within a menu level is shown in the display.

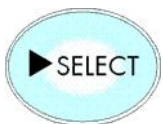

The SELECT key has two main functions. It gives the user access to a particular menu and, once in the menu, it allows the user to select a particular function.



As an alternative the INFO key can be used as well.

["Function"]

Functions / Changing of function values:



Within one function the value can be changed by pressing the NEXT key or the PREVIOUS key.



In case of a multi-digit function value the value of the currently chosen digit will be changed.

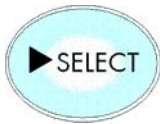

In case of a multi-digit function value pressing the SELECT key switches to the next position of the function value.



Pressing the RETURN key switches to the previous digit of the function value.

Please note: If you press the RETURN key although the absolute left digit of the function value is still arrived, the changing procedure will be cancelled and this moves you to the next menu level above.

If you press the SELECT key although the absolute right digit (digit 1) of the function value is still arrived, the currently displayed function value is stored.

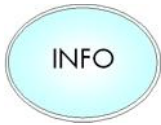

Pressing the INFO key the displayed function value is confirmed respectively the displayed function is activated. (As an alternative the SELECT key can be used as well; compare description above.) The changes are saved temporary. (This means, the changes are saved only until the next printer power off).

[Save as Setup?]

After this you have to decide, if you want to save the changes permanent (Save as setup).

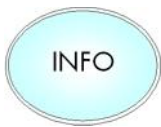

To select such changes permanently, the user must press the INFO key or the SELECT key one more time. These permanent changes in printer configuration are active each time the printer is turned on again.

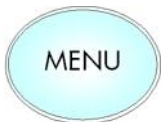

If the MENU key is pressed instead, the changes are only stored temporary (not saved as setup). (This key takes the user to the respective previous menu level).

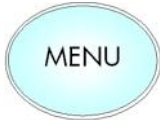
Return to the menu level above:

Pressing the RETURN key or the MENU key takes the user back to the respective menu level above.

Return to the ON LINE - mode:

Pressing the START/STOP key switches the user directly to "ON LINE" from any menu position.

4.7. Syntax of Diagrams

The control panel functions will be described using diagrams. These diagrams show the course necessary in order to activate a certain function.

First the elements of the diagrams are explained:

The sequence on the left describes which keys have to be pressed briefly in succession.

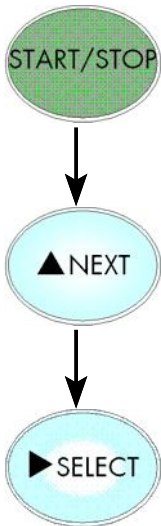

In this example the START/STOP key has to be pressed first. Then the START/STOP key has to be released and the NEXT key has to be pressed. Then the NEXT key has to be released and the SELECT key has to be pressed.

["Message"]

The "Panel display" column shows the display messages corresponding to the sequences listed on the left.

In the column "Notes" explanations to particular operational steps are given.



5. Panel Functions



For the panel functions described in the following text, the printer is presumed to be switched on and in the ON LINE-mode.

5.1. Printing the Status Sheet

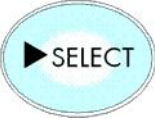
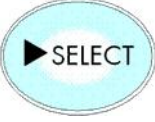
This function generates a status sheet. The status sheet contains information about the current printer configuration, the available fonts and options.

<u>Panel display</u>	<u>Notes</u>
[SOLID 50 A3 - 3]	
	Turn the printer OFF LINE with this key.
↓	
	[Menu Level 1]
↓	
	[Status Sheet]
↓	
	[Status Sheet]
↓	
	Press the SELECT key. Menu Level 1 is selected.
	Press the SELECT key again.
	A status sheet is printed.
	The printer is turned ON LINE again.

Status sheet contents:

The first lines, entitled SERVICE INFORMATION, contain hexadecimal coded configuration parameters.





Printed in plain text:

- Controller version / memory / serial number
- Firmware release
- Interface
 - parameters of Parallel, Serial, USB, Network (Ethernet)
- Network
 - parameters and addresses
- Printer emulation
- User-RAM / free User-RAM
- Input data buffer
- Transparent code
- Paper size
- Default margins
 - top / left
 - bottom / right
- Default character code
- Options
- Fonts installed (Font banks)

Note: Use the panel function `Printing the Font List` to show the fonts installed (see the following section).

5.2. Printing the Font List

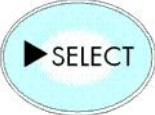
This function generates a list of all fonts installed to the printer. The font list shows demo prints of all fonts and, in addition, the concerning PCL selection commands. These commands contain information on font width and font height (see section 5.21 Font Selection, too).

	<u>Panel display</u>	<u>Notes</u>
	[SOLID 50 A3 - 3]	
		Turn the printer OFF LINE with this key.
↓		
	[Menu Level 1]	Menu Level 1 is selected.
↓		
	[Status Sheet]	Press the NEXT or PREVIOUS key until [Font List] is displayed.
↓	• • •	
	[Font List]	
↓		
	[Font List]	The font list is printed.
		The printer is turned ON LINE again.

5.3. Choosing Print Resolution

This function allows the user to choose the current print resolution. If, after a particular resolution is chosen, the print data stream indicates a different resolution (e.g. via a WINDOWS print driver), the second print resolution will be used only for that job.

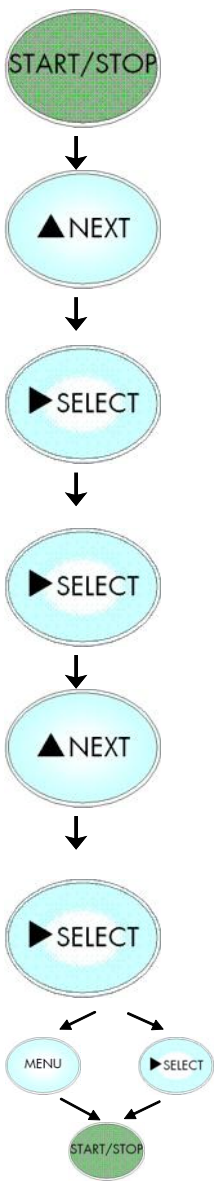
<u>Panel display</u>	<u>Notes</u>
	
[SOLID 50 A3 - 3]	
[Menu Level 1]	Turn the printer OFF LINE with this key.
...	
[Engine]	Press the NEXT or PREVIOUS key until [Engine] is displayed.
	Menu item Engine is selected.
[Resolution]	
	Menu item Resolution is selected.
[300 dpi]	
	Press the NEXT or PREVIOUS key until the desired resolution (e.g. 600 dots per inch) is displayed.
...	
[600 dpi]	
	600 dpi resolution is selected.
[Save as Setup?]	In addition this new value can be saved as setup value (using the SELECT key), before the printer is turned ON LINE again.

Remarks on choosing print resolution (Fonts):

By selecting 300 dpi resolution the printing system will be compatible for all applications (300 dpi data stream), also the 300 dpi font banks (bitmap writing) are available.

If 600 dpi resolution is chosen, the corresponding fonts must be loaded into the printer server (e.g. True Type fonts, scalable download fonts).

5.4. Hexdump-Mode Activation

In the Hexdump-Mode the printer prints all characters received via interface without any interpretation (hexadecimal coded). This mode helps with error diagnosis. The Hexdump-Mode can be activated only temporarily.

Panel display

Notes



[SOLID 50 A3 - 3]

Turn the printer OFF LINE with this key.



[Menu Level 1]

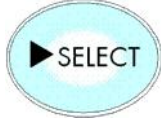

Menu Level 1 is selected.



[Status Sheet]



Press the NEXT or PREVIOUS key until [Hexdump] is displayed.

...



[Hexdump]

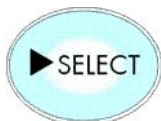

[Hexdump]

The Hexdump-Mode is activated.







The printer is turned ON LINE again.

Note:

By activating the normal print mode (see next page) or by turning the printer off and on again the printer can be taken out of Hexdump-Mode. Time between turning the printer off and on again should be at least 15 seconds.

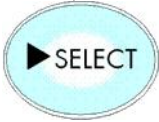
5.5. Normal Print Mode Activation (incl. FORM FEED)

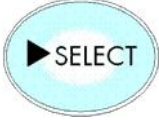



The normal print mode suspends the Hexdump-Mode. This function is activated, when a print job must be continued without turning the printer off and on again. In addition to that the function "Normal Print Mode Activation" is used to produce a FORM FEED.

	<u>Panel display</u>	<u>Notes</u>
	[SOLID 50 A3 - 3]	
↓		
	[Menu Level 1]	Turn the printer OFF LINE with this key.
↓		
	[Status Sheet]	Menu Level 1 is selected.
↓		
...		Press the NEXT or PREVIOUS key until [Normal Print/FF] is displayed.
↓		
	[Normal Print /FF]	
↓		
	[Normal Print/FF]	The normal print mode is activated.
		The printer is turned ON LINE again.

Note: After activating the normal print mode a FORM FEED is released automatically and one sheet is put out. This is necessary because after a test in the Hexdump-Mode it is possible that data can remain in the input buffer unintentionally (cause: in the Hexdump-Mode no control characters are evaluated and no FORM FEED is effected).

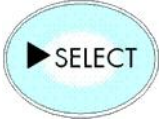
5.6. Clearing the Input Buffer (Cancel Job)

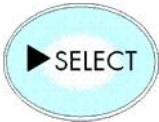

This function permits the resumption of a print job at a particular page after a print interruption (e.g. paper jam). The data contained in the input buffer before the interruption are cleared.

	<u>Panel display</u>	<u>Notes</u>
	[SOLID 50 A3 - 3]	
↓		Turn the printer OFF LINE with this key.
	[Menu Level 1]	
↓		Menu Level 1 is selected.
	[Status Sheet]	
↓	...	Press the NEXT or PREVIOUS key until [Cancel Job] is displayed.
	[Cancel Job]	
↓		All data contained in the input buffer will be cleared.
	[Cancel Job]	
		The printer is turned ON LINE again.

5.7. Printing the Menu Page



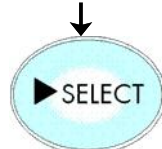
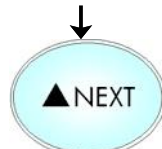

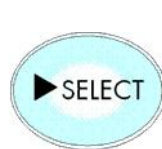
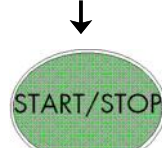
This function prints a survey of the available panel functions.

Note: When printing the menu page please use a large paper.

	<u>Panel display</u>	<u>Notes</u>
	[SOLID 50 A3 - 3]	Turn the printer OFF LINE with this key.
	[Menu Level 1]	Menu Level 1 is selected.
	[Status Sheet]	Press the NEXT or PREVIOUS key until [Menu Page] is displayed.
	...	
	[Menu Page]	A menu structure presentation of the SOLID 50 A3 - 3 (see section 4.6) is printed.
	[Menu Page]	
		The printer is turned ON LINE again.

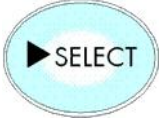
5.8. Generating Testsheets (Sliding Pattern)

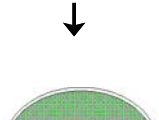
This function generates a series of test prints without sending data to the printer.
 These test prints facilitate error analysis.

<u>Panel display</u>	<u>Notes</u>
	
↓	
	[SOLID 50 A3 - 3]
↓	
	[Menu Level 1]
↓	
	[Status Sheet]
↓	
	...
↓	
	[Sliding Pattern]
↓	
	[Sliding Pattern]
	A series of test prints is generated.
	The printer is turned ON LINE again.



The printing out of test prints can be stopped by pressing the START/STOP key.

5.9. Feeder (Cassette) Selection

This function enables the user to choose a particular feeder (cassette).

Note: If automatic format check is enabled (see section 5.13), the current paper size has priority. The paper size selection overrides the feeder selection (compare section 5.12: Paper Size Selection). In addition this feeder selection is suspended by feeder selections via the data stream (feeder selections via the application software or printer driver override the settings made at the panel of the printer).

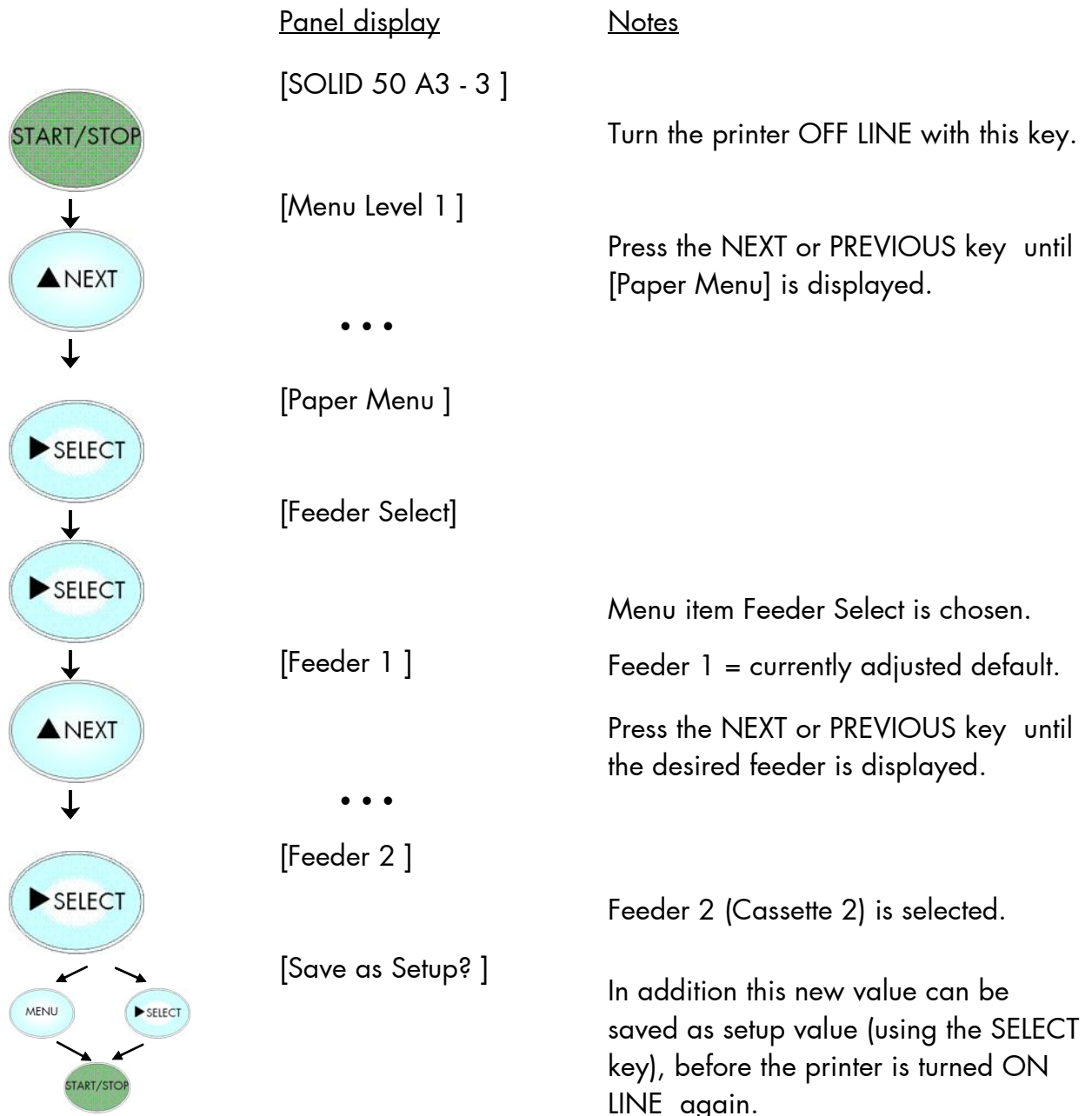

Feeder assignment:







Manual Feed	Multipurpose Feeder
Feeder 1	Upper Feeder (Cassette 1)
Feeder 2	Lower Feeder (Cassette 2) (The SOLID 50 A3-3 comes with cassette 1 and 2 (extent of supply). The third and fourth cassettes are optional. Compare section 2.5 Printer Components.)

...

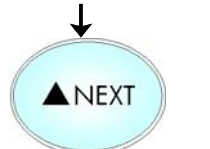
Auto. 2+1	Automatic selection between feeders (the subset of feeders is settable, tray 1+2 = default)
Auto.Sel. Mode	Automatic selection between all feeders that are installed (Feeder Linking)

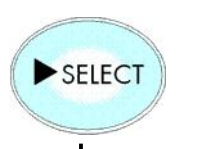
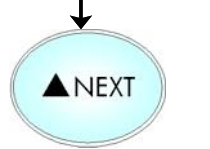
5.10. Stacker Selection

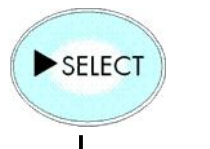
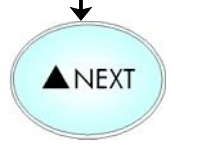
This function enables the user to choose a particular stacker.

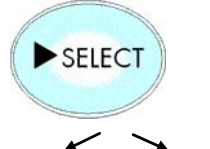
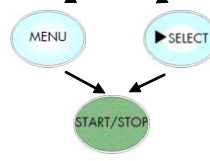
	<u>Panel display</u>	<u>Notes</u>
	[SOLID 50 A3 - 3]	Turn the printer OFF LINE with this key.
	[Menu Level 1]	Press the NEXT or PREVIOUS key until [Paper Menu] is displayed.
	...	
	[Paper Menu]	
	[Feeder Select]	Press the NEXT or PREVIOUS key until [Stacker Select] is displayed.
	...	
	[Stacker Select]	
	[Paper Tray 1]	Paper Tray 1 = Current default.
	...	
	[Paper Tray 2]	Paper Tray 2 is selected.
	[Save as Setup?]	In addition this new value can be saved as setup value (using the SELECT key), before the printer is turned ON LINE again.

Stacker assignment:







Paper Tray 1 Standard output bin (face down tray)

Paper Tray 2 Second output bin (optional finisher/stacker)

Paper Tray 3 Third output bin (optional finisher/stacker)

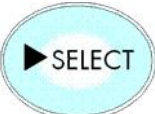
5.11. Print Mode Selection (Simplex/Duplex)

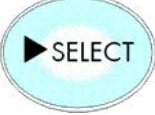
This function allows the user to choose between simplex and duplex printing (via the duplex unit).
(Simplex = one-sided printing, Duplex = double-sided printing).

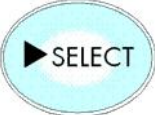
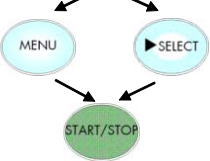
<u>Panel display</u>	<u>Notes</u>
	[SOLID 50 A3 - 3]
↓	
	[Menu Level 1]
↓	...
	[Paper Menu]
↓	[Feeder Select]
	
↓	...
	[Simpl. / Dupl.]
↓	[Simplex]
	
↓	...
	[Duplex Mode 1]
	[Save as Setup?]

Turn the printer OFF LINE with this key.

Press the NEXT or PREVIOUS key until [Paper Menu] is displayed.

Press the NEXT or PREVIOUS key until [Simpl. / Dupl.] is displayed.

Press the NEXT or PREVIOUS key until the desired print mode is displayed.

The duplex mode 1 is selected.

In addition this new value can be saved as setup value (using the SELECT key), before the printer is turned ON LINE again.

Information about the Print Mode command:

This command switches „intelligent“ printing on the front and rear side of a page on and off.

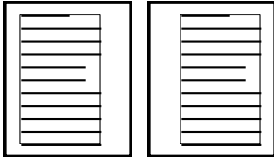
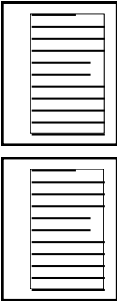
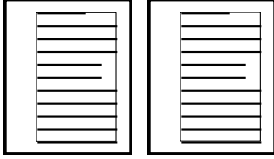
Duplex Mode	Description
0	Switches duplex print mode off
1	Duplex print mode long format-side, with rear side displacement
	
2	Duplex print mode short format-side, without rear side displacement
	
3	Duplex print mode long format-side, without rear side displacement for preprinted paper
4	Duplex print mode short format-side, without rear side displacement for preprinted paper
5	Duplex print mode long format-side, without rear side displacement
	

5.12. Paper Size Selection

This function selects the size of the print page (print image).

Note: In addition this feeder selection is suspended by feeder selections via the data stream (feeder selections via the application software or printer driver override the settings made at the panel of the printer).

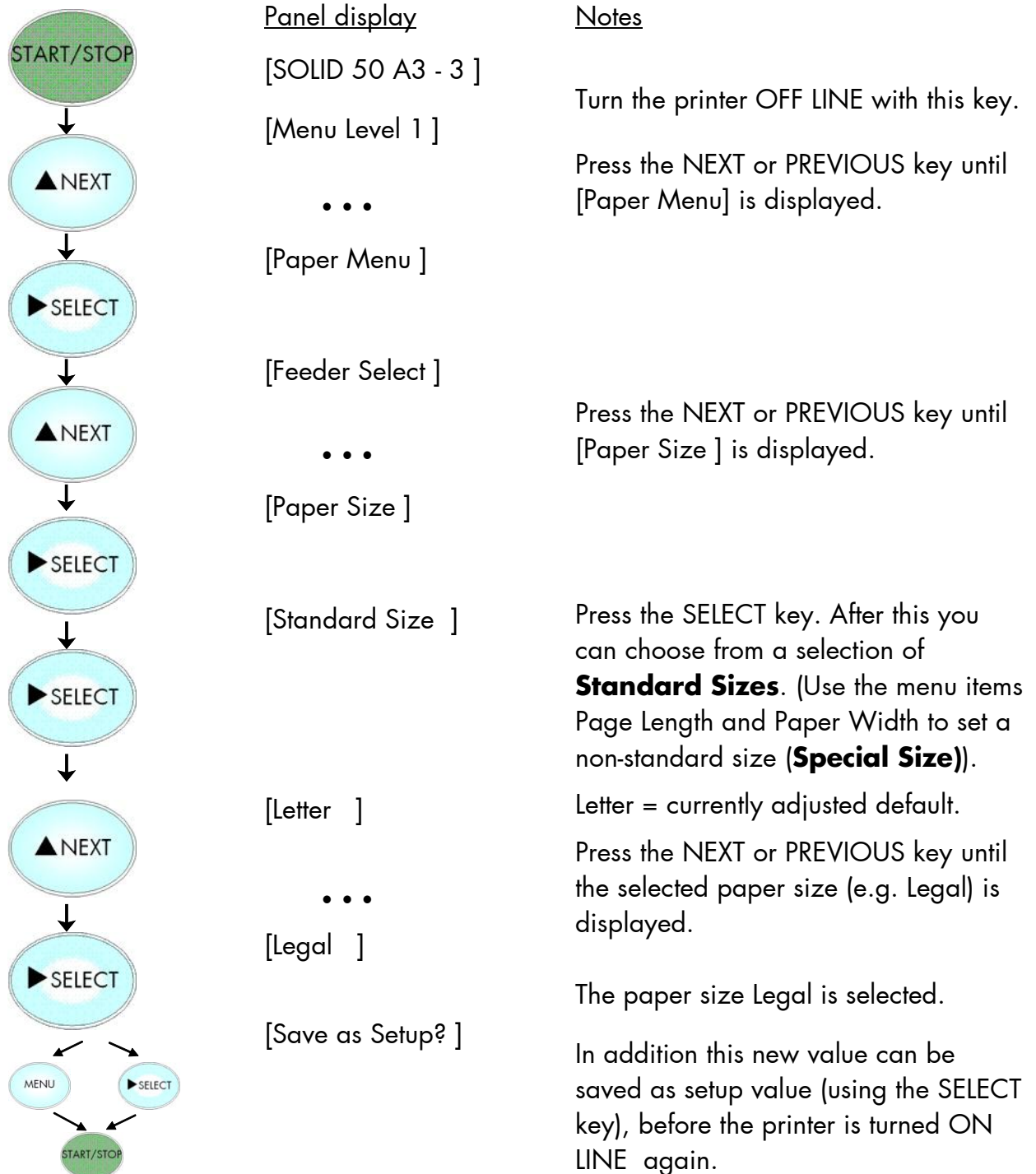

5.13. Enabling Format Check

This function is used to enable or disable automatic format check of the printer. If format check is active, the MPC identifies format commands in the data stream and prevents for example printing on undersized paper.

Hint: If format check is disabled, every feeder selection / cassette selection is carried out (even if the paper in the selected feeder is too small for the print image).

Note: For the multipurpose feeder the separate panel function [Fmt.Chk.Man.Feed] has to be used in the same manner.

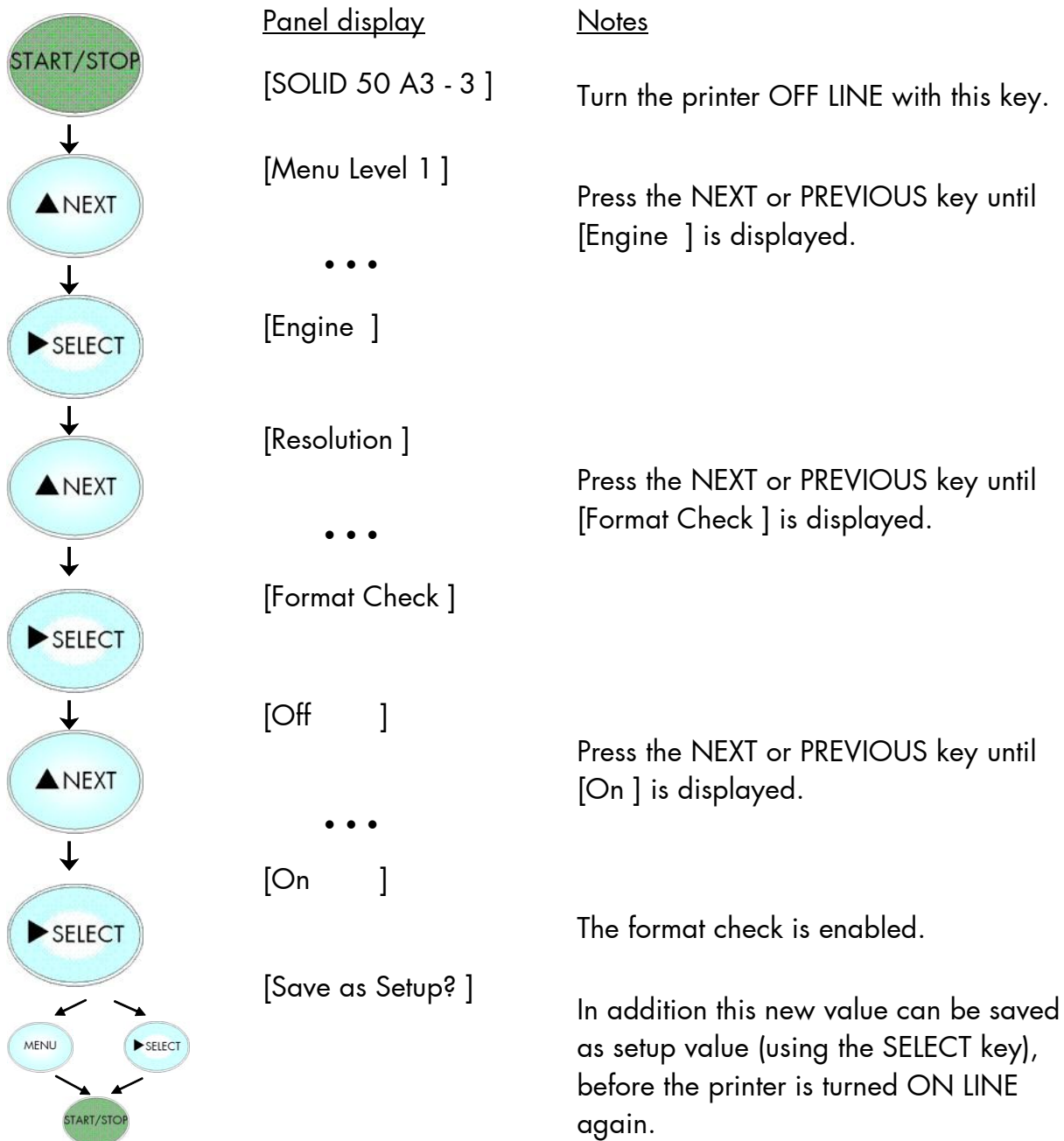

5.14. Print Direction Selection

This function selects the active print orientation (orientation of the whole printout including graphics, etc. on the paper).

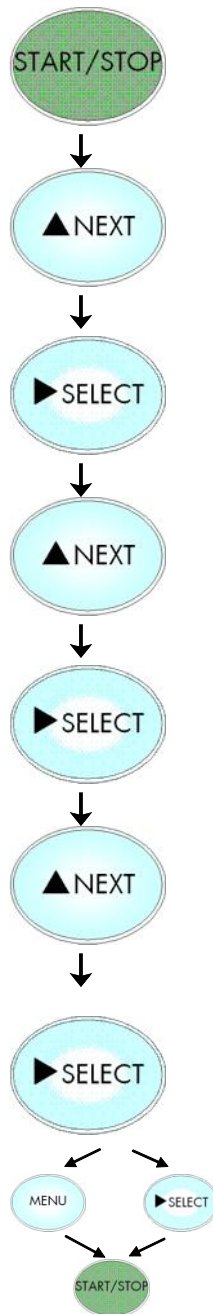

Panel display

[SOLID 50 A3 - 3]

[Menu Level 1]

...

[Paper Menu]

[Feeder Select]

...

[Print Direct.]

[Print Direct. 0]

...

[Print Direct. 1]

[Save as Setup?]

Notes

Turn the printer OFF LINE with this key.

Press the NEXT or PREVIOUS key until [Paper Menu] is displayed.

Press the NEXT or PREVIOUS key until [Print Direct.] is displayed.

Press the NEXT or PREVIOUS key until the desired print direction is displayed.

The print direction 1 = landscape is selected.

In addition this new value can be saved as setup value (using the SELECT key), before the printer is turned ON LINE again.

Print direction assignment:

- Print direction 0 = Portrait (upright format)
- Print direction 1 = Landscape (horizontal format)
- Print direction 2 = Portrait upside down
- Print direction 3 = Landscape upside down

5.15. Data - Interface Configuration

This function is used to set the interface parameters.

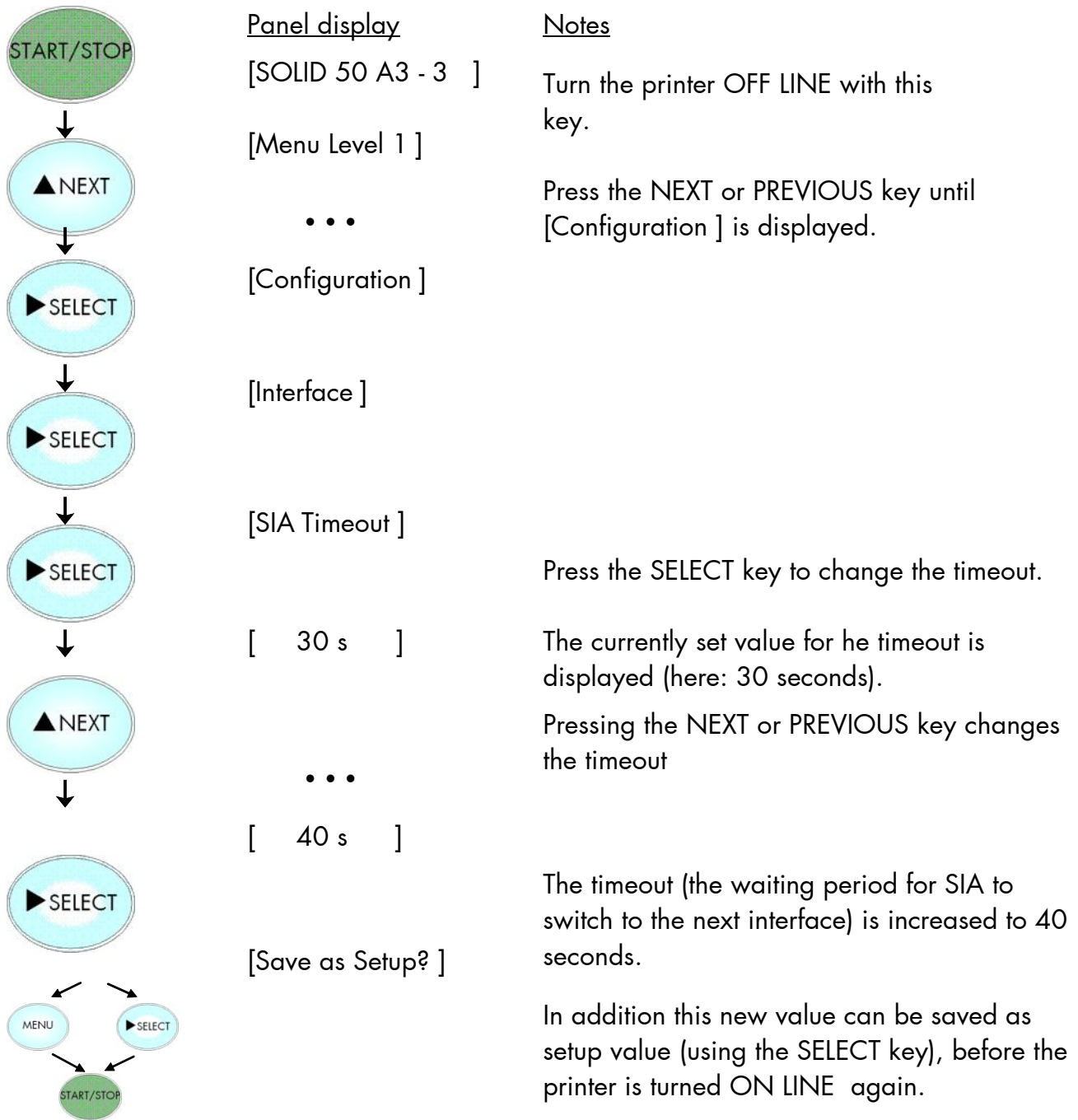

Note: The printer uses SIA (Simultaneous Interface Administration) to check, which interface is currently used for the transfer of print data.

5.16. Emulation Selection

This function helps to determine which printer emulation will be activated.

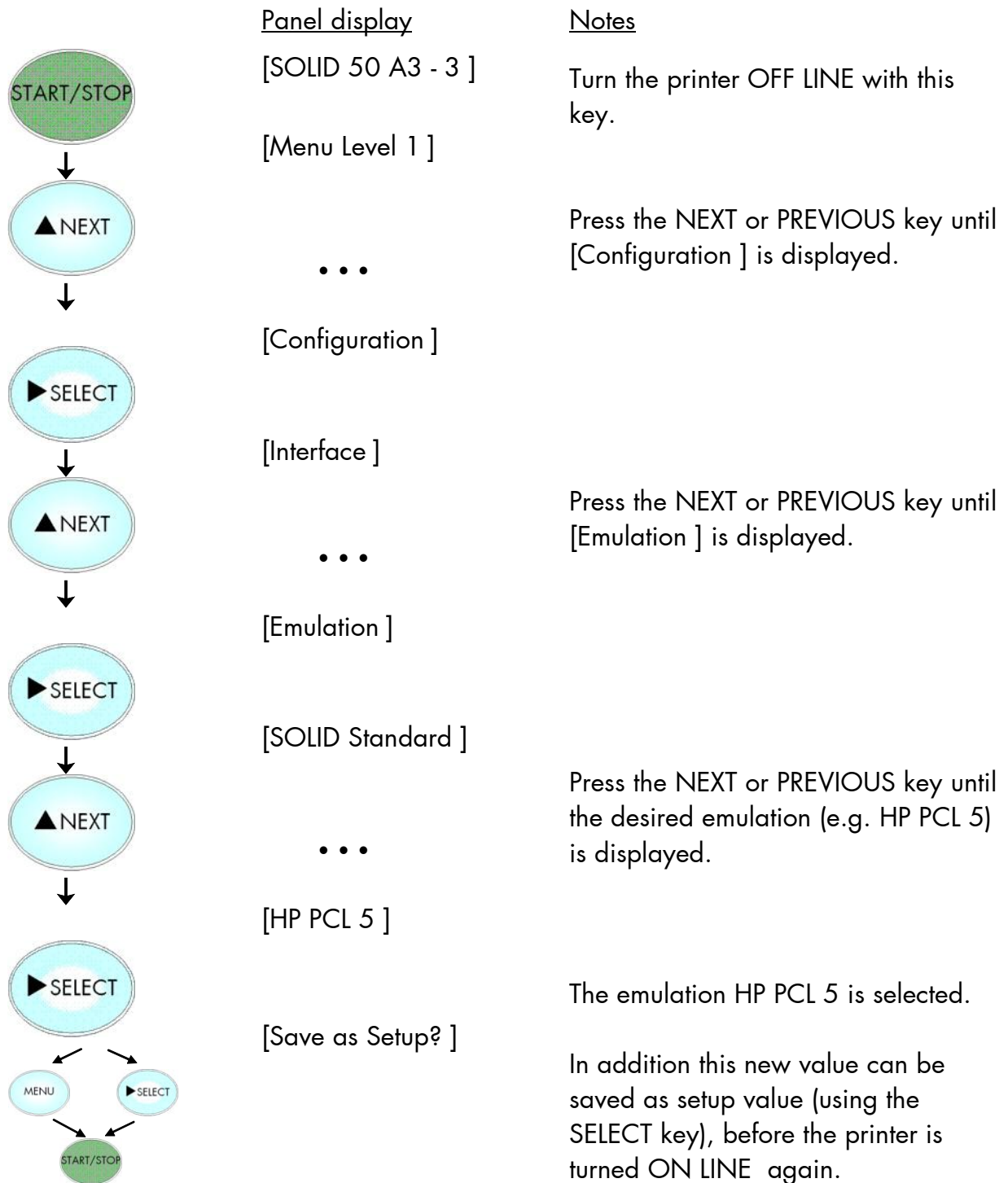

Available emulations:

Standard:

MICROPLEX IDOL,
HP LaserJet (PCL 5),
IBM Proprinter,
Diablo 630,
Epson FX,
TIFF (CCITT group 4),
µPostscript

Optional:

Kyocera Prescribe,
Printronix IGP/PGL,
QMS (Magnum) Code V,
ZPL II (Zebra Programming Language),
Datamax (FGL),
Eltron EPL2,
Express

(More emulations on request)

Notice:

The brand names mentioned are registered trademarks of the enterprises named above.

5.17. Display Language Selection

This function enables the user to determine the language for the display messages, the status sheet and the font list.

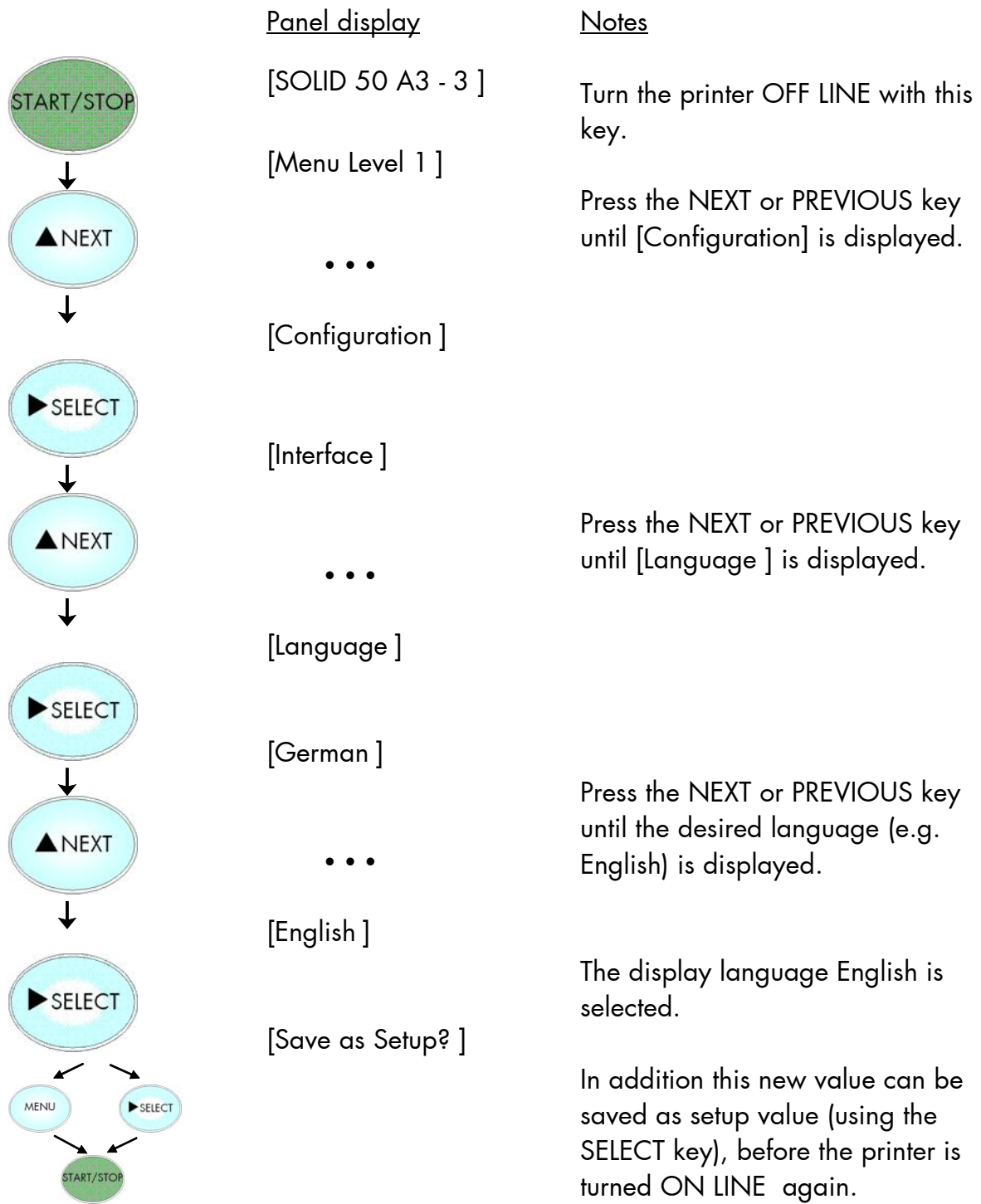

Turn the printer OFF LINE with this key.

Press the NEXT or PREVIOUS key until [Configuration] is displayed.

Press the NEXT or PREVIOUS key until [Language] is displayed.

Press the NEXT or PREVIOUS key until the desired language (e.g. English) is displayed.

The display language English is selected.

In addition this new value can be saved as setup value (using the SELECT key), before the printer is turned ON LINE again.





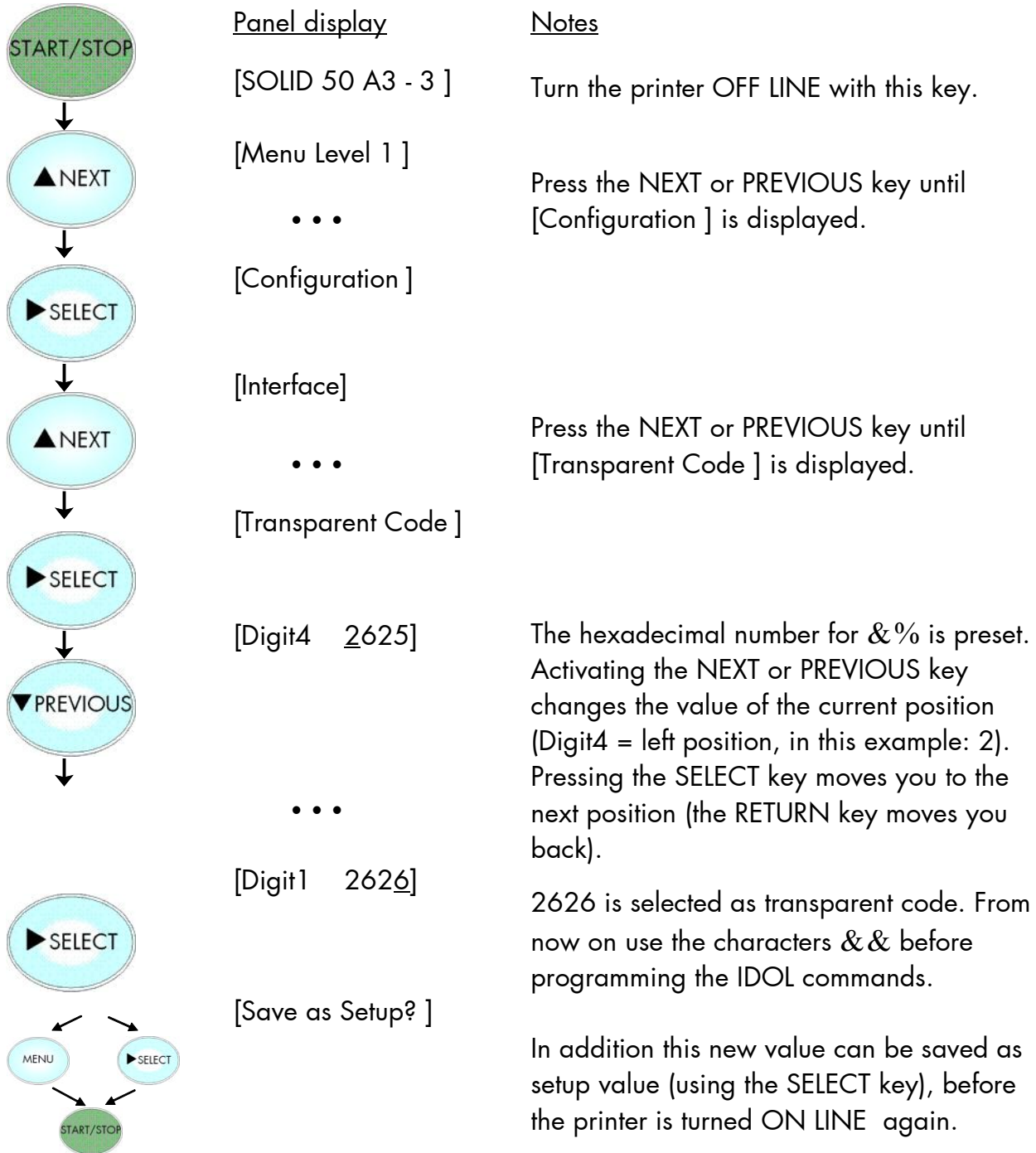

5.18. Transparent Code Adjustment

This function configures the transparent code. Using the transparent code enables you to initiate the commands of the page description language IDOL by **printable** characters. The transparent code pre-setting is 2625. These are the ASCII character codes (hexadecimal) for the characters &% (ref. IDOL Programming Manual).



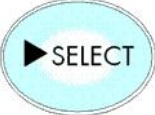

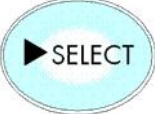

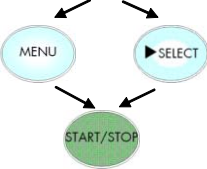
5.19. Selection of Memory Distribution (Input Buffer)

This function enables the user to choose the distribution of the available RAM memory between input buffer and macro/download memory.

	<u>Panel display</u>	<u>Notes</u>
↓	[SOLID 50 A3 - 3]	Turn the printer OFF LINE with this key.
	[Menu Level 1]	
↓	...	Press the NEXT or PREVIOUS key until [Configuration] is displayed.
	[Configuration]	
↓	[Interface]	Press the NEXT or PREVIOUS key until [Input Buffer] is displayed.
	...	
↓	[Input Buffer]	
	[32 kB]	Press the NEXT or PREVIOUS key until the desired memory distribution is displayed. The input buffer size is specified in kilobyte (kB) or in percent of the installed memory.
	...	
↓	[100 kB]	
	[Save as Setup?]	100 kB is selected as input buffer.
		In addition this new value can be saved as setup value (using the SELECT key), before the printer is turned ON LINE again.



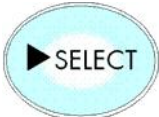

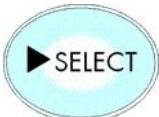
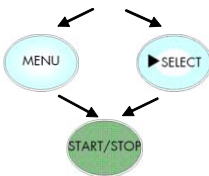
5.20. Setting to Factory Default

This function back-outs all configurations to factory defaults.

	<u>Panel display</u>	<u>Notes</u>
	[SOLID 50 A3 - 3]	Turn the printer OFF LINE with this key.
↓	[Menu Level 1]	
	...	Press the NEXT or PREVIOUS key until [Configuration] is displayed.
↓	[Configuration]	
	[Interface]	Press the NEXT or PREVIOUS key until [Factory Default] is displayed.
↓	...	
	[Factory Default]	
↓	[Factory Default]	Only if you press the SELECT key a second time the configuration will be back-outed to factory defaults.
	[Save as Setup?]	
		The printer is turned ON LINE again.

5.21. Font Selection

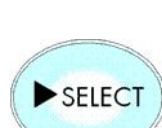
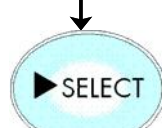
This function selects the active font. Select a font number out of the list of available fonts.

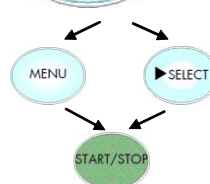
	<u>Panel display</u>	<u>Notes</u>
	[SOLID 50 A3 - 3]	Turn the printer OFF LINE with this key.
	[Menu Level 1] ... [Page Menu]	Press the NEXT or PREVIOUS key until [Page Menu] is displayed.
	[Font Number]	
	[Font 0600]	
	[Font 0600] ... [Font 5507]	Press the NEXT or PREVIOUS key until the desired font number (5507 Langeoog e.g.) is displayed.
	[Font 5507]	The font number 5507 Langeoog is selected.
	[Save as Setup?]	In addition this new value can be saved as setup value (using the SELECT key), before the printer is turned ON LINE again.

The **SOLID 50 A3 - 3 standard equipment** contains the following **fonts**:

<u>Font no.</u>	<u>Font width</u>	<u>Font height</u>	<u>Font name</u>
0600	10	12	Kurilen
0602	10	12	Kurilen Italic
0610	12	10.1	Kurilen
1710	12	10.1	Kurilen Italic
4508	P	8.1	Helgoland
4510	P	10	Helgoland
4714	P	14.4	Helgoland Bold
5507	20	7	Langeoog
5508	16.6	7.9	Langeoog
5509	15	9.1	Langeoog
6610	10	10.1	Juist Monosp.
9210	P	10.1	Tasmanien
9310	P	10.1	Tasmanien Italic
2000	P	SC	Tasmanien
9900	P	SC	Neuwerk

Resumption of this standard font list see next page.

Explanations:

Font width:

Character distance in CPI (Characters Per Inch).

P = proportional, (meaning that each character has an individual width).

Font height:

Font height from the lowest descender to the upper edge of the highest character, measured in graphical points (1/72 inch).

SC = scalable.

	<u>Font no.</u>	<u>Font width</u>	<u>Font height</u>	<u>Font name</u>
	0050	SC		Plakatschrift
	0590	SC		OCR /B
	0591	SC		OCR /A
	6600	SC		Juist Monospaced
PCL 5 compatible	0699	SC		Kurilen
	1700	SC		Kurilen Italic
	1800	SC		Kurilen Bold
	1900	SC		Kurilen Bold Italic
	5500	SC		Langeoog
	5600	SC		Langeoog Bold
	5700	SC		Langeoog Italic
	5800	SC		Langeoog Bold Italic
	2100	P	SC	Texel Bold
	2200	P	SC	Texel Italic
	2300	P	SC	Texel Bold Italic
	9800	P	SC	Neuwerk Italic
	9500	P	SC	Neuwerk Bold Italic
	9600	P	SC	Neuwerk Bold
	0060	SC		Plakatschrift
	9501	P	SC	Neuwerk-II Condensed Italic
	9601	P	SC	Neuwerk-II Condensed Bold Ital.
	9801	P	SC	Neuwerk-II Condensed Bold
	9901	P	SC	Neuwerk-II Condensed
	0530	P	SC	PiktoWin
	5100	P	SC	Amrum
	5200	P	SC	Amrum Bold
	5300	P	SC	Amrum Italic
	7500	P	SC	Antigua
	7700	P	SC	Antigua Bold
	7800	P	SC	Antigua Italic
	7900	P	SC	Antigua Bold Italic
	9199	P	SC	Tasmanien-II Bold Italic
9299	P	SC	Tasmanien-II	
9399	P	SC	Tasmanien-II Italic	
9499	P	SC	Tasmanien-II Bold	

Notes: Additional fonts can be selected from the font catalogue depending upon the memory capacity.

You can use the panel function Printing the Font List (see section 5.2) to generate a list of all fonts installed to the printer.

5.22. Text Orientation Selection

This function selects the active text orientation.

Panel display

Notes

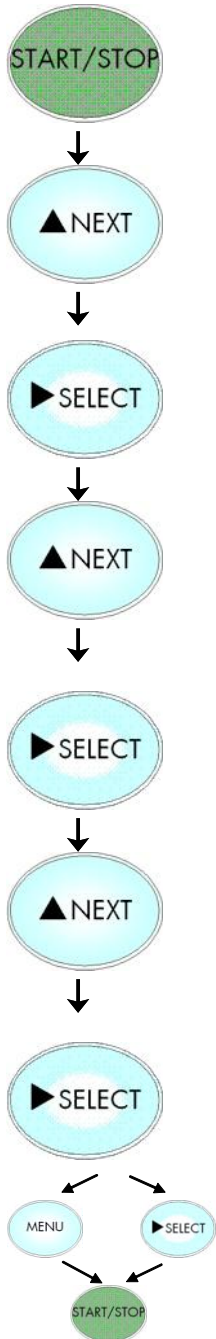

[SOLID 50 A3 - 3]

Turn the printer OFF LINE with this key.

[Menu Level 1]

Press the NEXT or PREVIOUS key until [Page Menu] is displayed.

...

[Page Menu]

[Font Number]

Press the NEXT or PREVIOUS key until [Orientation] is displayed.

...

[Orientation]

[Orientation 0]

Press the NEXT or PREVIOUS key until the desired orientation is displayed.

...

[Orientation 1]

The orientation 1 = landscape is selected.

[Save as Setup?]

In addition this new value can be saved as setup value (using the SELECT key), before the printer is turned ON LINE again.

Text orientation assignment:

Orientation 0 = Portrait (upright format)







Orientation 1 = Landscape (horizontal format)

Orientation 2 = Portrait upside down

Orientation 3 = Landscape upside down

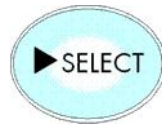
5.23. Symbol Code Selection

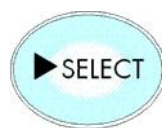
This function selects the active symbol code.

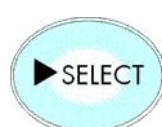
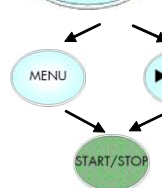
	<u>Panel display</u>	<u>Notes</u>
	[SOLID 50 A3 - 3]	Turn the printer OFF LINE with this key.
↓ 	[Menu Level1]	Press the NEXT or PREVIOUS key until [Page Menu] is displayed.
↓	...	
	[Page Menu]	
↓	[Font Number]	
	...	Press the NEXT or PREVIOUS key until [Symbol Code] is displayed.
↓	[Symbol Code]	
	[902, IBM PC-II]	
↓	...	Press the NEXT or PREVIOUS key until the desired symbol code is displayed.
	[901, IBM PC-I]	
↓		The symbol code 901, IBM PC-I is selected.
	[Save as Setup?]	In addition this new value can be saved as setup value (using the SELECT key), before the printer is turned ON LINE again.
		

5.24. Configuration of Text Margins

This function sets text margins. Margins are expressed in dots at the concerning edge of the paper.

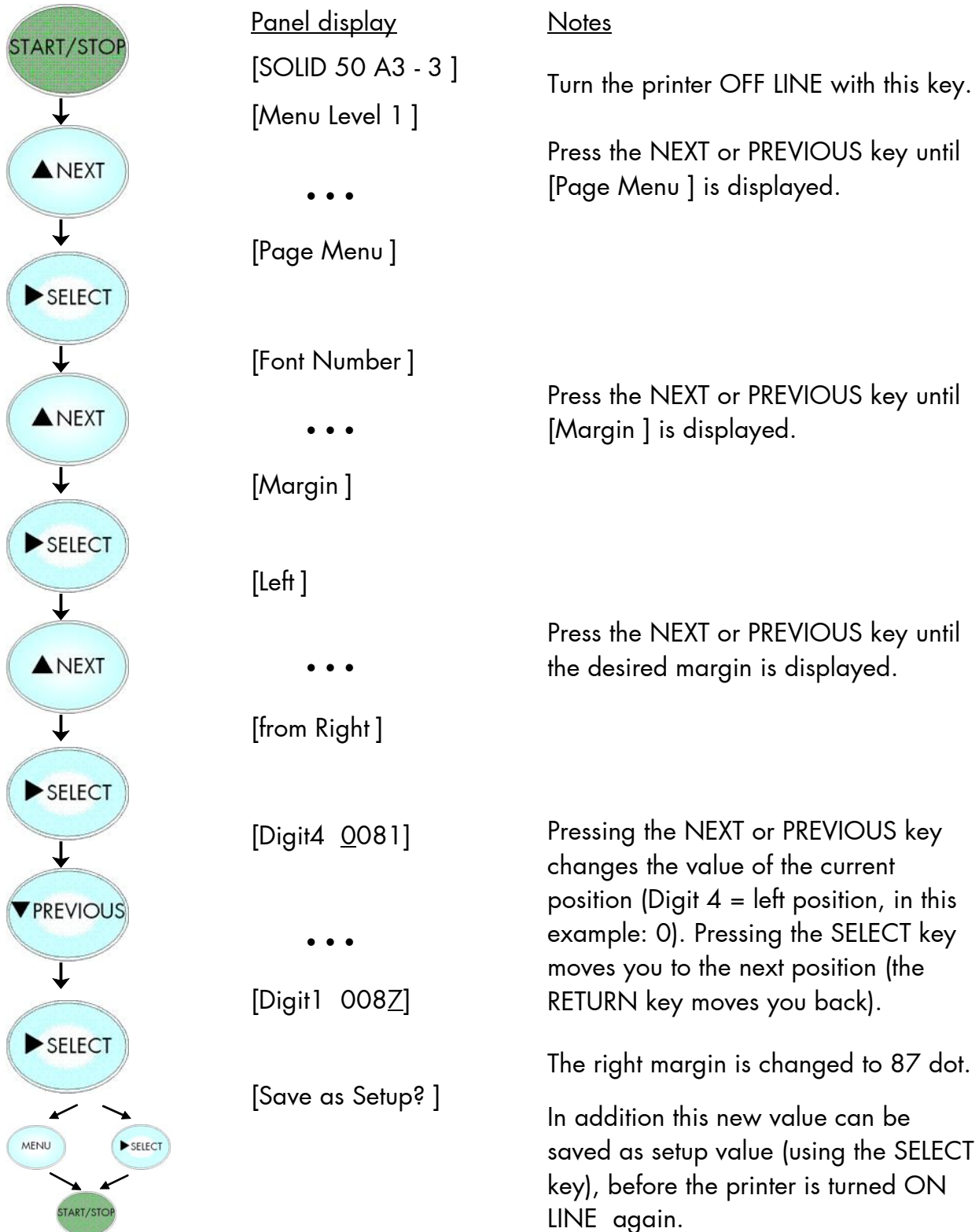

Turn the printer OFF LINE with this key.

Press the NEXT or PREVIOUS key until [Page Menu] is displayed.

Press the NEXT or PREVIOUS key until [Margin] is displayed.

Press the NEXT or PREVIOUS key until the desired margin is displayed.







Pressing the NEXT or PREVIOUS key changes the value of the current position (Digit 4 = left position, in this example: 0). Pressing the SELECT key moves you to the next position (the RETURN key moves you back).

The right margin is changed to 87 dot.

In addition this new value can be saved as setup value (using the SELECT key), before the printer is turned ON LINE again.

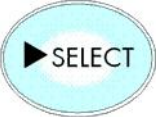
5.25. Image Shifting to the X-Direction

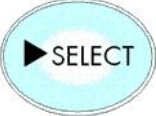
This function shifts the print image in relation to the paper to the X-direction (crosswise the print direction).

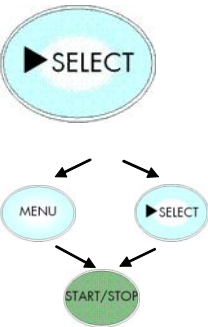
	<u>Panel display</u>	<u>Notes</u>
↓	[SOLID 50 A3 - 3]	Turn the printer OFF LINE with this key.
	[Menu Level 1]	
↓	...	Press the NEXT or PREVIOUS key until [Engine] is displayed.
	[Engine]	
↓	[Resolution]	Press the NEXT or PREVIOUS key until [Image X-Pos.] is displayed.
	...	
↓	[Image X-Pos.]	The panel function Image Shifting to the X-Direction is selected.
	[X-Pos.: = 008 Dot]	
↓	...	8/300 inch = currently set value. Operating the NEXT or PREVIOUS key the value for the image shift can be altered. Settable are pos. and neg. values up to about 1 inch (= 25.4 mm).
	[X-Pos.: = 016 Dot]	
↓	[Save as Setup?]	Now the image has been shifted for 16/300 inch (about 1.36 mm) to the right.
		In addition this new value can be saved as setup value (using the SELECT key), before the printer is turned ON LINE again.

Example for shifting the image to the X-direction:

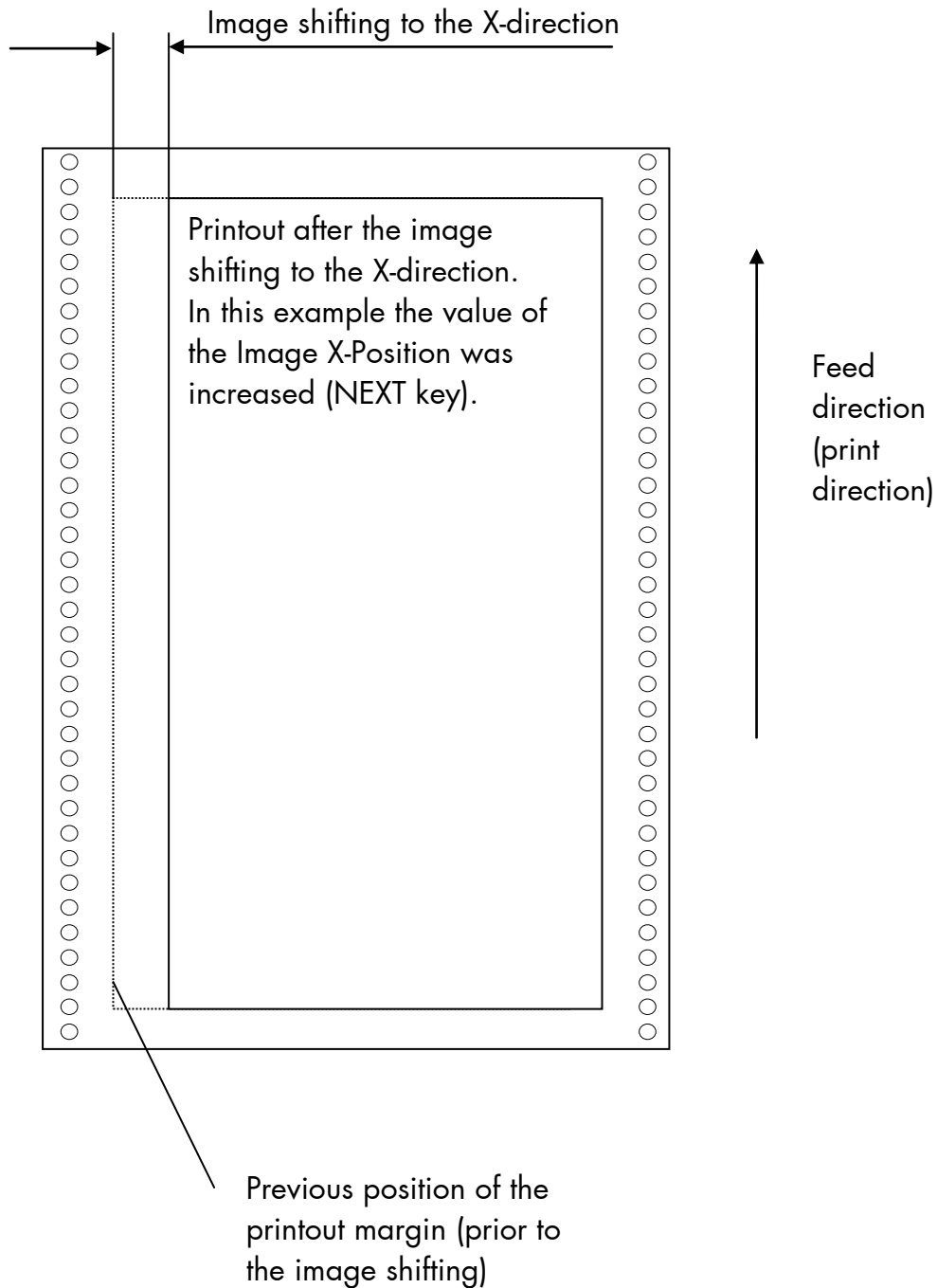

5.26. Image Shifting to the Y-Direction

This function shifts the print image in relation to the paper to the Y-direction (print direction).

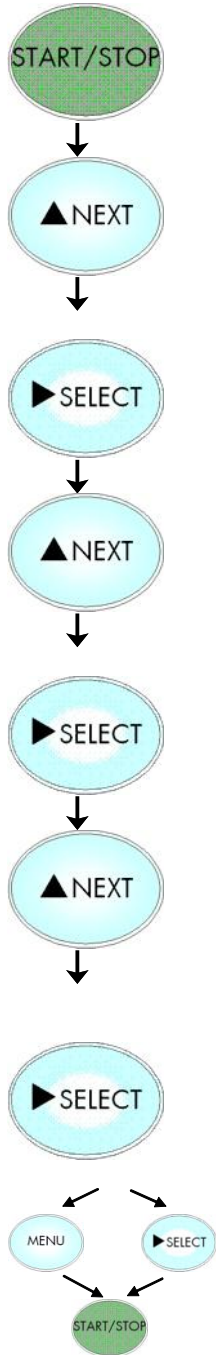

Panel display

Notes

[SOLID 50 A3 - 3]

Turn the printer OFF LINE with this key.

[Menu Level 1]

Press the NEXT or PREVIOUS key until [Engine] is displayed.

...

[Engine]

[Resolution]

Press the NEXT or PREVIOUS key until [Image Y-Pos.] is displayed.

...

[Image Y-Pos.]

[Y-Pos.: = 104 Dot]

Approx. 1/3 Inch = currently set value.

Operating the NEXT or PREVIOUS key the image can be shifted relative to the paper. Settable are pos. and neg. values up to about 2 inch (=50.8mm).

...

[Y-Pos.: = 296 Dot]

Now the image has been shifted for 296/300 inch (approx. 1 Inch) against the print direction.

[Save as Setup?]

In addition this new value can be saved as setup value (using the SELECT key), before the printer is turned ON LINE again.

Example for shifting the image to the Y-direction:

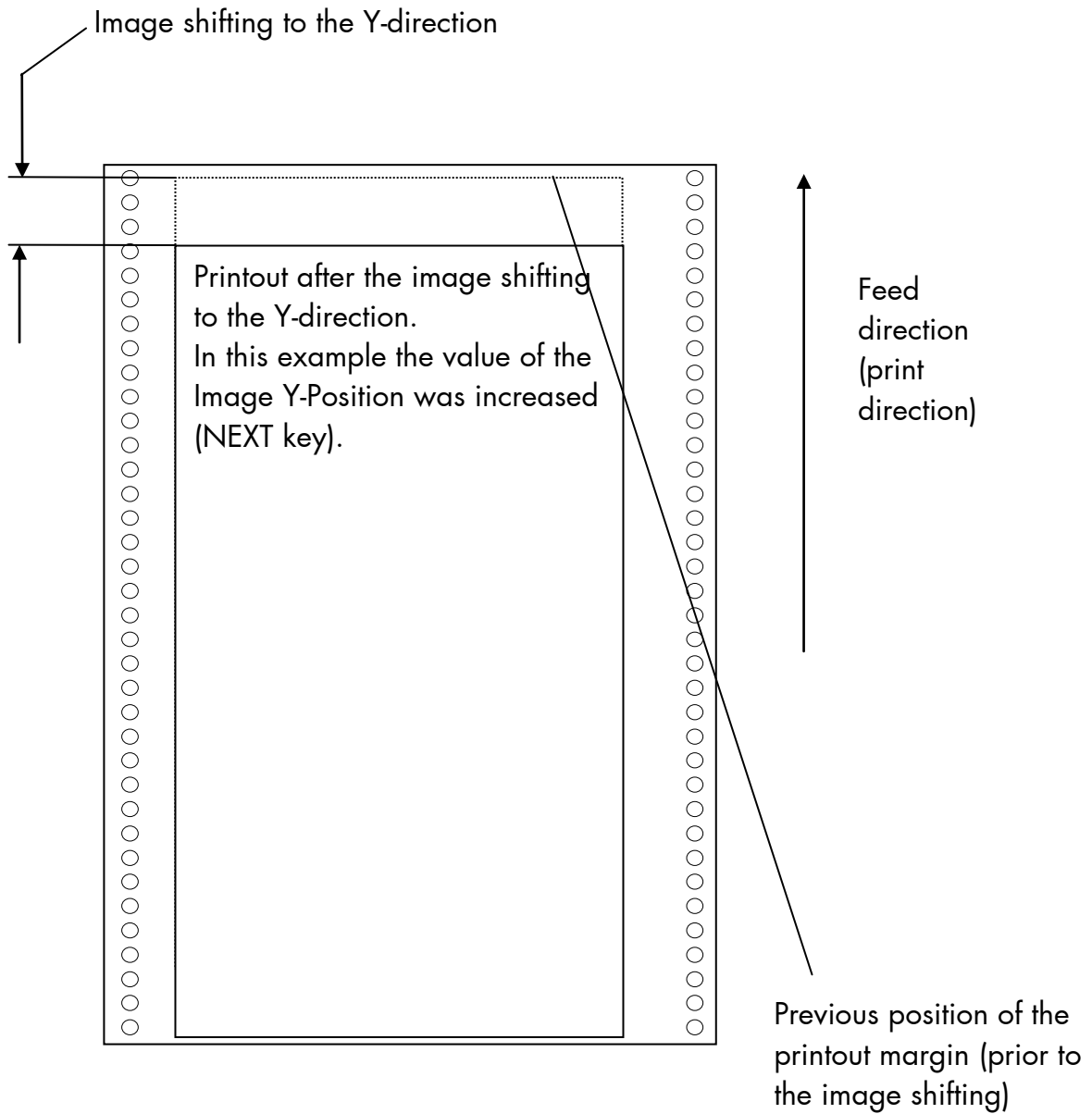

5.27. Lines per Inch Setting (Line Spacing)

This function sets the number of lines per inch. This setting is effective only in case of using the printer as a line printer.

With a small number of lines per inch, line spacing will be relatively large. (Ref. IDOL Programming Manual).

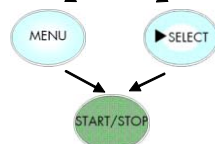
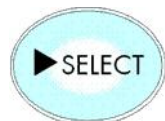
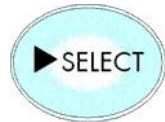
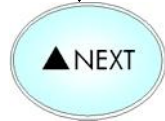
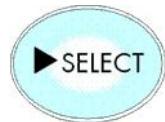

Panel display

[SOLID 50 A3 - 3]

[Menu Level 1]

...

[Page Menu]

[Font Number]

...

[Line Spacing]

[Digit4 006.5]

...

[Digit1 010.0]

[Save as Setup?]

Notes

Turn the printer OFF LINE with this key.

Press the NEXT or PREVIOUS key until [Page Menu] is displayed.

Press the NEXT or PREVIOUS key until [Line Spacing] is displayed.

6.5 lpi = currently set value.
(**lines per inch**).

Pressing the NEXT or PREVIOUS key changes the value of the current digit (Digit 4 = left position, in this example: 0). Pressing the SELECT key moves you to the next digit (the RETURN key moves you back, if need be).

The number of lines per inch was increased to 10 lpi.

In addition this new value can be saved as setup value (using the SELECT key), before the printer is turned ON LINE again.

5.28. Number of Characters per Inch Setting (Character Spacing)

This function sets the number of characters per inch. This setting is effective only in case of using a line printer emulation. With a small number of characters per inch, character spacing will be relatively large. (Ref. IDOL Programming Manual).

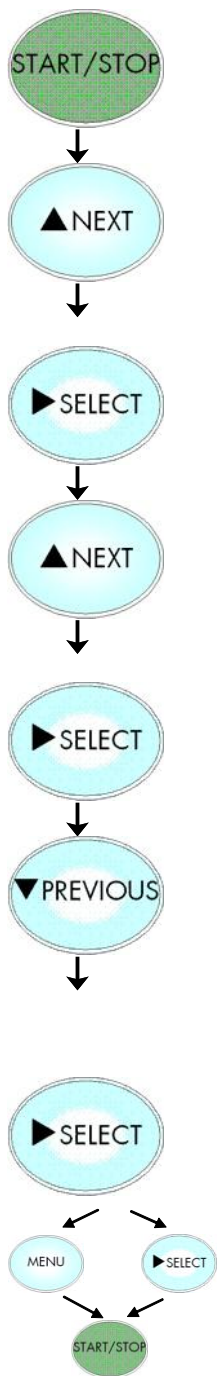

Panel display
[SOLID 50 A3 - 3]
[Menu Level 1]

Notes
Turn the printer OFF LINE with this key.

...
[Page Menu]

Press the NEXT or PREVIOUS key until [Page Menu] is displayed.

[Font Number]
...
[Char. Spacing]

Press the NEXT or PREVIOUS key until [Char. Spacing] is displayed.

[Digit4 013.3]
...
[Digit1 012.0]

13.3 cpi = currently set value. (characters per inch). Pressing the NEXT or PREVIOUS key changes the value of the current digit (Digit 4 = left position, in this example: 0. Pressing the SELECT key moves you to the next digit (the RETURN key moves you back, if need be).

[Save as Setup?]

The number of characters per inch was reduced to 12 cpi. In addition this new value can be saved as setup value (using the SELECT key), before the printer is turned ON LINE again.

5.29. Print Density Setting

Using this function the density of the printed characters can be changed.



Selecting a low print density value reduces the amount of toner on the printed page. This may help lower the cost of printing.

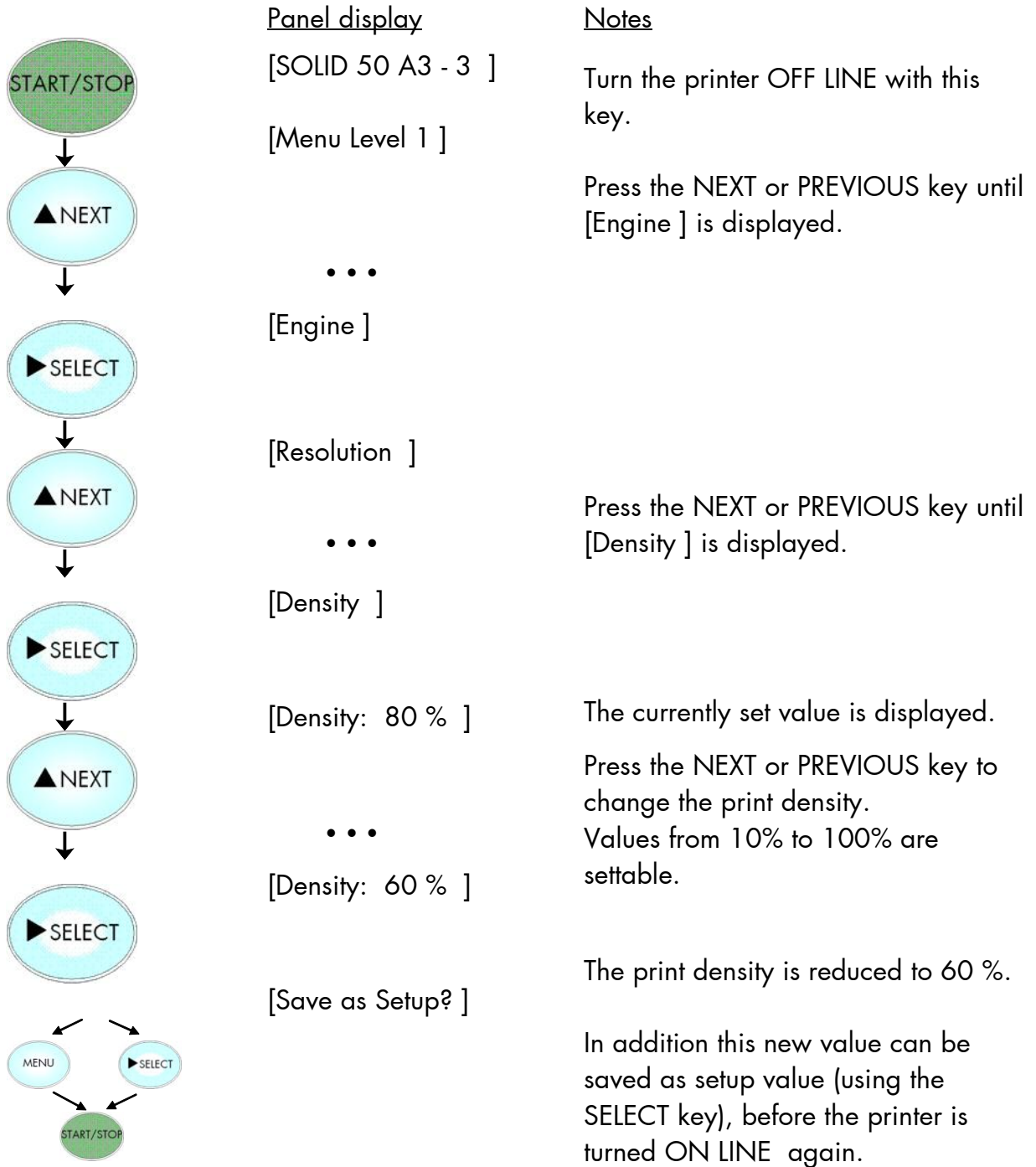

5.30. Configuration of Network Parameters (IP Address, e.g.)

The functions of the submenu Network are used to set the parameters for connecting the printer to a network (Ethernet).

Setting the IP address manually:

START/STOP	Panel display	Notes
↓	[SOLID 50 A3 - 3]	Turn the printer OFF LINE with this key.
▲NEXT	[Menu Level 1]	Press the NEXT or PREVIOUS key until
↓	• • •	[Network] is displayed.
▶SELECT	[Network]	Press the SELECT key to select the
↓	[Timeout]	network menu.
▲NEXT	• • •	Press the NEXT or PREVIOUS key until
↓	[Ethernet]	[Ethernet] is displayed.
▶SELECT		Press the SELECT key to select the
↓	[Duplex/Speed]	Ethernet menu.
▲NEXT	• • •	Press the NEXT or PREVIOUS key until
↓	[IP Assign]	[IP Assign] is displayed.
▶SELECT		Press the SELECT key to select the
↓	[Off]	IP Assing menu.
▲NEXT	• • •	The current configuration is displayed.
↓	[Manual]	Press the NEXT or PREVIOUS key until
▶SELECT		[Manual] is displayed.
↓	[IP Address]	Press the SELECT key to set the
▶SELECT	[192.168.002.002]	IP address manually.
↓		Pressing the NEXT or PREVIOUS key
▼PREVIOUS	• • •	changes the value of the current digit
↓		(left digit first, in this example: 1).
▶SELECT	[192.168.010.123]	Pressing the SELECT key moves you to
↓		the next position (the RETURN key
▶SELECT	[Saved !]	moves you back, if need be).
↓		The new IP address is saved as setup
START/STOP		value.
		The printer is turned ON LINE again.

Notes: If your network is using DHCP^①, an address can be automatically assigned (select the item **DHCP** from the network submenu IP Assign).

The parameters **Subnet Mask** and **Gateway** are configured in the same way as described above. Please select the concerning panel functions for this (compare section 5.6 Menu Structure).

Select the subitem **Off** from the network menu to switch off the network access.

^① Dynamic Host Configuration Protocol: offers among other things a centralized address management.

Duplex/Speed Setting

This panel function is located in the network menu (submenu Duplex/Speed Setting).

The factory default value is Autonegotiation.

Autonegotiation means that devices on the network agree a transmission mode, which each unit is able to handle, before data transmission starts. By this the printer automatically adjusts itself to maximize link performance.

Hint: Autonegotiation is the recommended setting!

If you set the Duplex/Speed parameters manually, you may experience problems. Wrong settings can slow down the speed of the link (worst case: communication does not occur).

Explanations:

Auto-Negotiation

A Ethernet procedure that allows devices at either end of a link segment to advertise and negotiate modes of operation such as the speed of the link (100 Mbit/s or 10 Mbit/s) and half- or full-duplex operation.

Half duplex

A device can either receive or send data at a given time.

Full duplex

Capability of a device for sending and receiving data at the same time. In the case of full duplex, collision detection is deactivated. A full duplex capable device is able to buffer data packets.

6. Operator Maintenance

In order to operate the printer on the highest quality level, it is necessary to carry out simple cleaning operations, and occasionally to replace special components.

These operations can be carried out by a MICROPLEX trained operator. A untrained person is not allowed to carry out these operations.

6.1. Printer Cleaning



For safety pull out the main plugs first. Make sure the elements that are to be cleaned have cooled down.

Please be especially careful to avoid damaging mechanical or electronical modules.

Do not use detergents, or any other devices or tools not mentioned in this manual to avoid damages and unnecessary costs of repairs.

6.1.1. Printer Cabinet Cleaning

Soilings like dust, grease or similar things can be removed with a soft, lint-free cloth. If necessary the cloth can be moistured with water or a neutral detergent. Inside the printer dust or paper dust can be removed best with a soft (non-metallic) brush.

6.2. Replacing the Transfer Roller and Fuser

After 300,000 letter-size pages have printed, it is time to replace the items in the maintenance kit. The transfer roller and the fuser are parts of the maintenance kit.

Check the tag at the rear of the printer to determine the voltage of your printer.

If 120 V is on the tag, order a low-voltage maintenance kit.

For 220 V, order a high-voltage maintenance kit.

The maintenance kit contains the items in the following illustration.

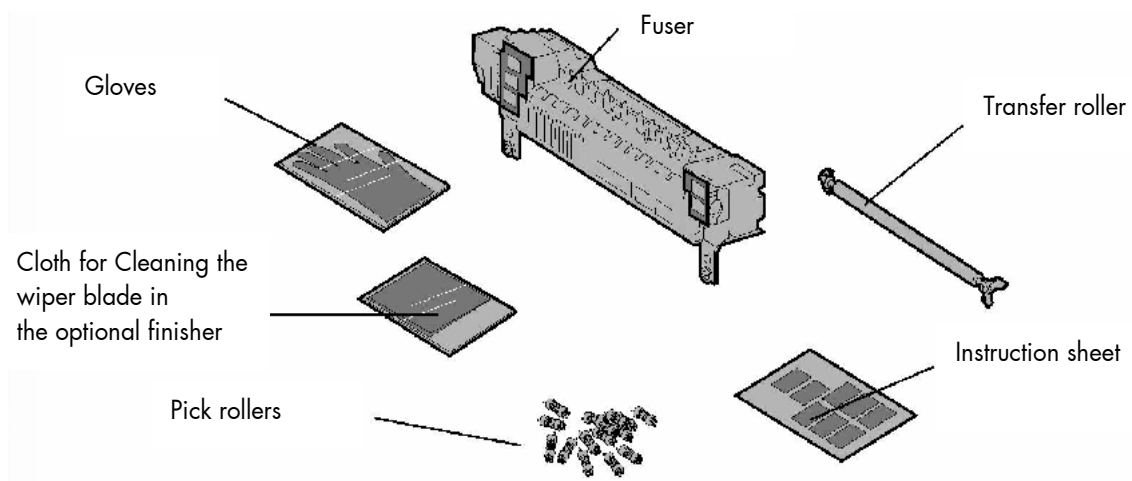

Fig. 6.2.a Maintenance kit

Unpack each box and remove any packaging. Wear the gloves as you replace the fuser to keep your hands clean.

Removing the old transfer roller

1. Turn the printer off.
2. Pull up on the handle to open the printer side door (Door A).

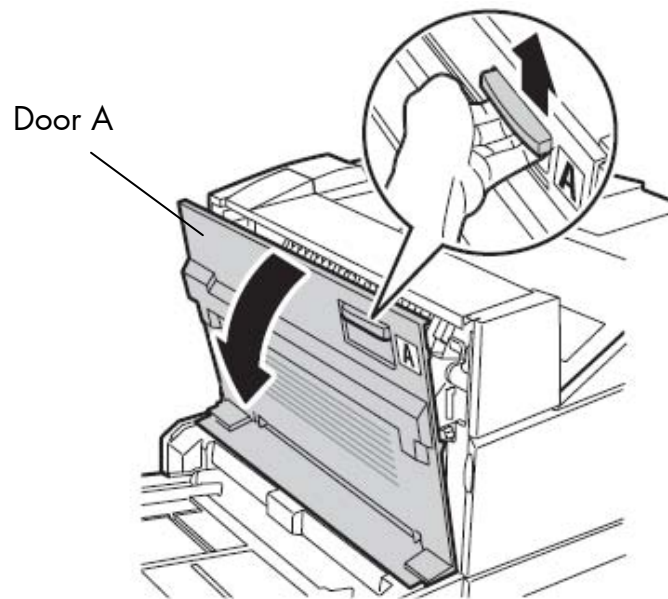

Fig. 6.2.b Releasing the side door (Door A)

3. Gently lower the door to the open position.



Caution: Some components inside door A may be hot.

4. Use both hands to press the levers of the transfer roller.

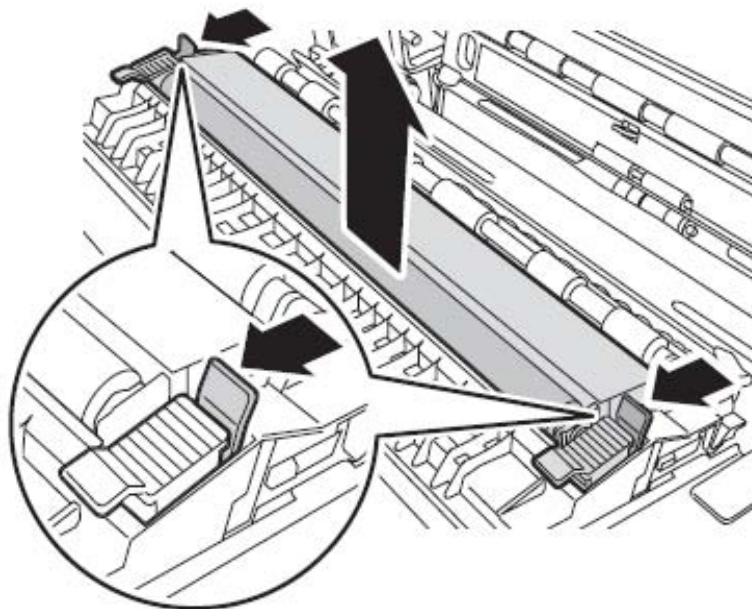

Fig. 6.2.c Grasp the coloured handles

5. Firmly pull the transfer roller out.

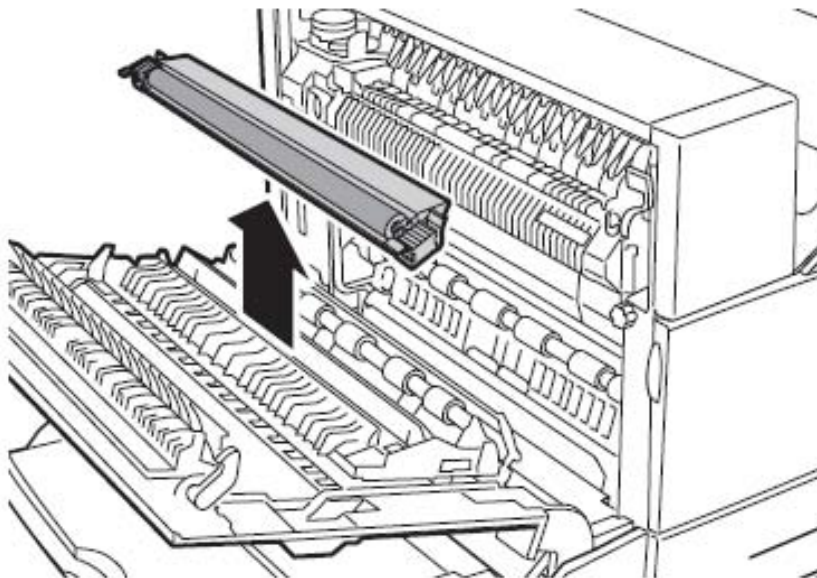

Fig. 6.2.d Pulling the old transfer roller out

Installing a new transfer roller

- Remove the packaging from the new transfer roller.

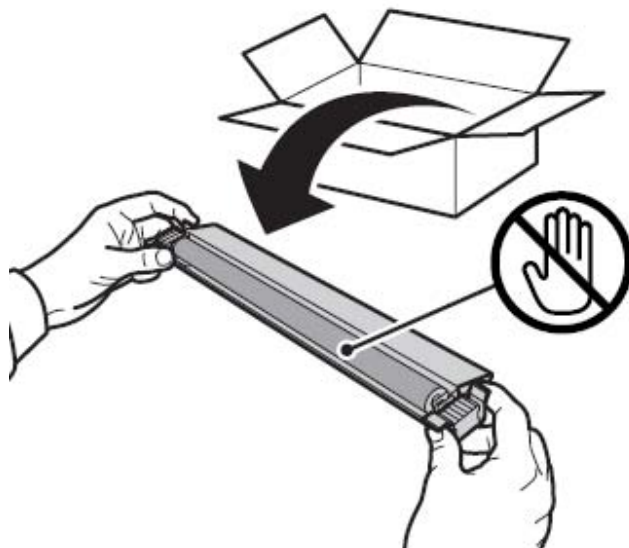

Fig. 6.2.e Unpacking the new transfer roller

- Align the transfer roller with the opening in the printer door A, and then slide it into place.

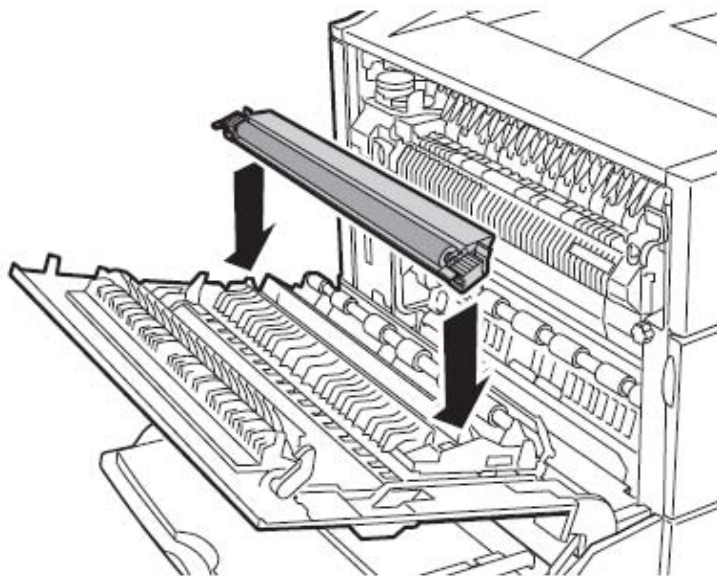

Fig. 6.2.f Sliding the new transfer roller into place

8. Push the transfer roller into the printer door A until it clicks into place.

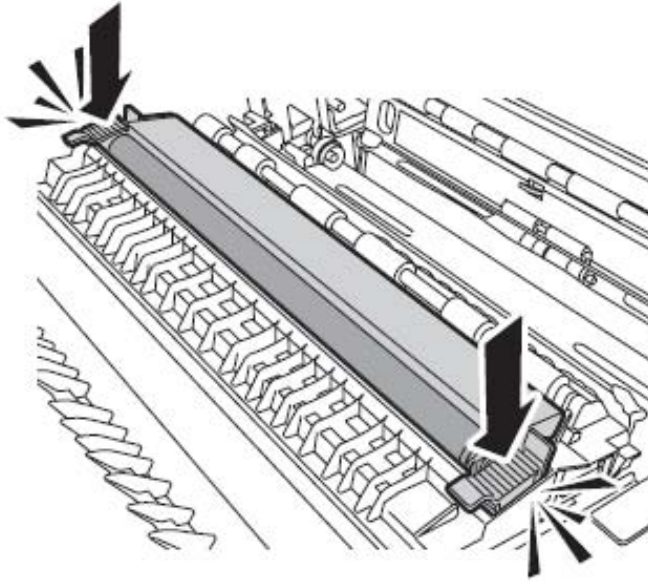

Fig. 6.2.g Inserting the new transfer roller

Removing the old fuser



The fuser may be hot. Allow time for it to cool before continuing. Use the handles on the fuser to remove it.

1. Loosen the two coloured thumbscrews. They do not come completely out.

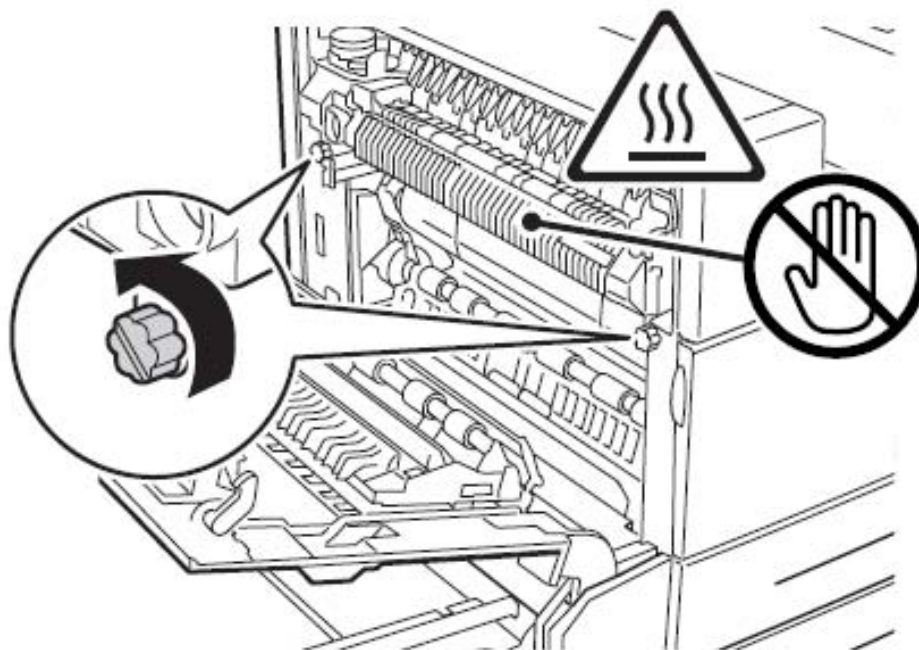

Fig. 6.2.h Loosening the two coloured thumbscrews

2. Grasp the coloured handles through its rings and rotate it out toward you. They do not lock into position.

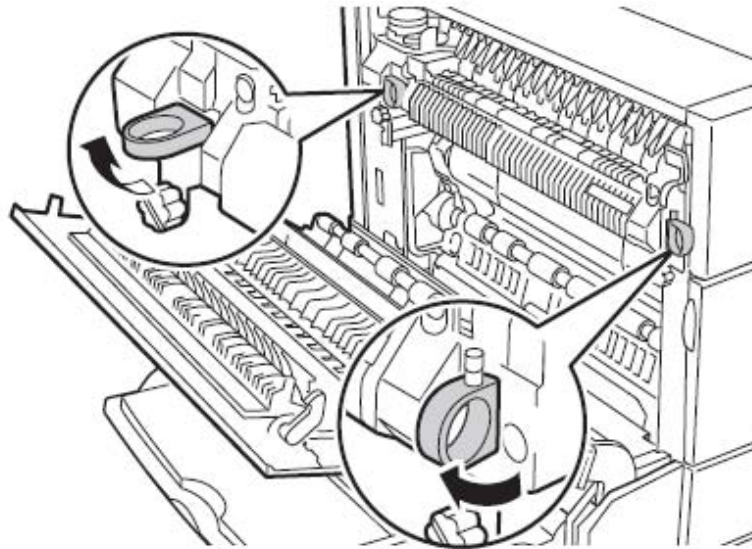

Fig. 6.2.i Grasp the coloured handles

3. Grasp both handles and firmly pull the fuser out.

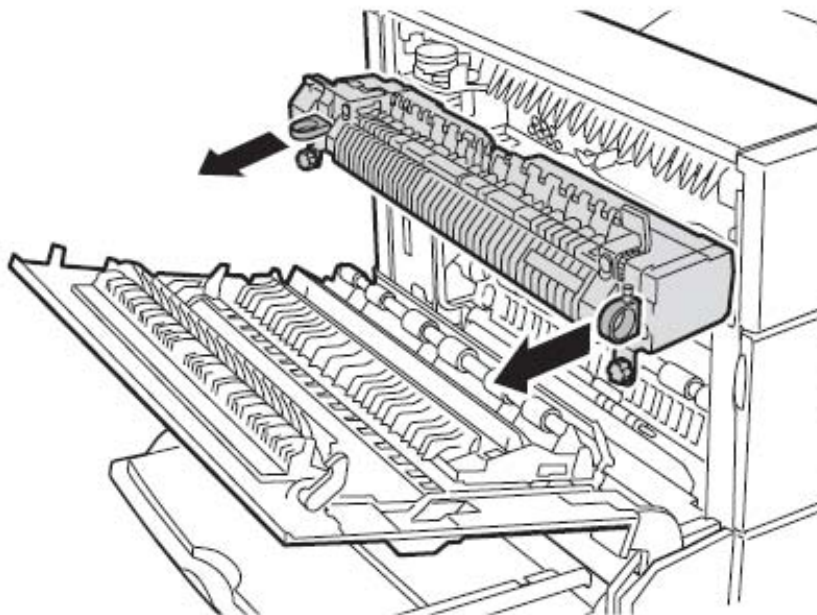

Fig. 6.2.j Pulling the old fuser out

4. Dispose of the old fuser.

Installing a new fuser

5. Remove the packaging from the new fuser.

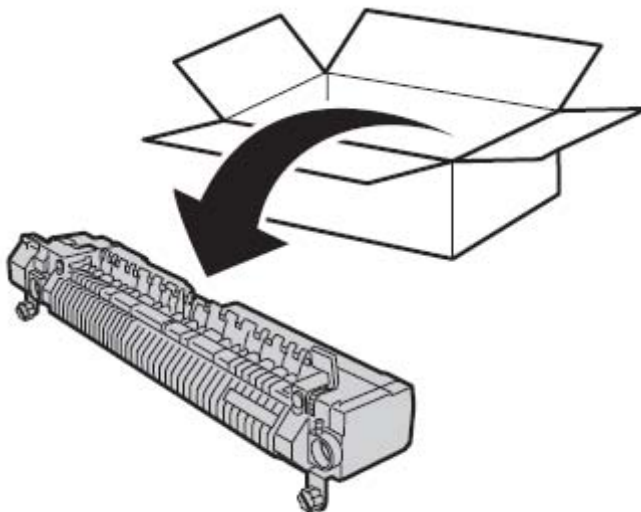

Fig. 6.2.k Unpacking the new fuser

6. Align the fuser with the opening in the printer, and then slide it into place.

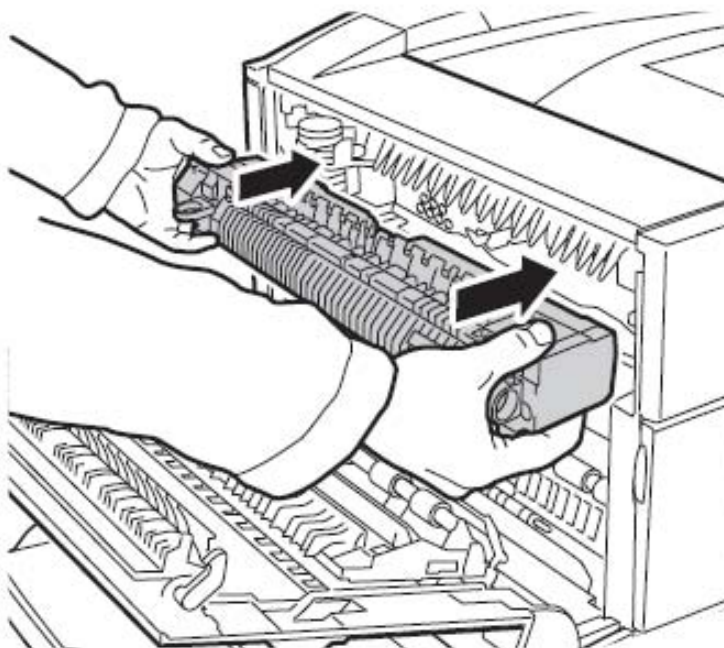

Fig. 6.2.l Sliding the new fuser into the printer



Push firmly on each side of the fuser near the handles until it is in place.

7. Carefully tighten the two coloured thumbscrews.



Overtightening the screws can strip the threads.

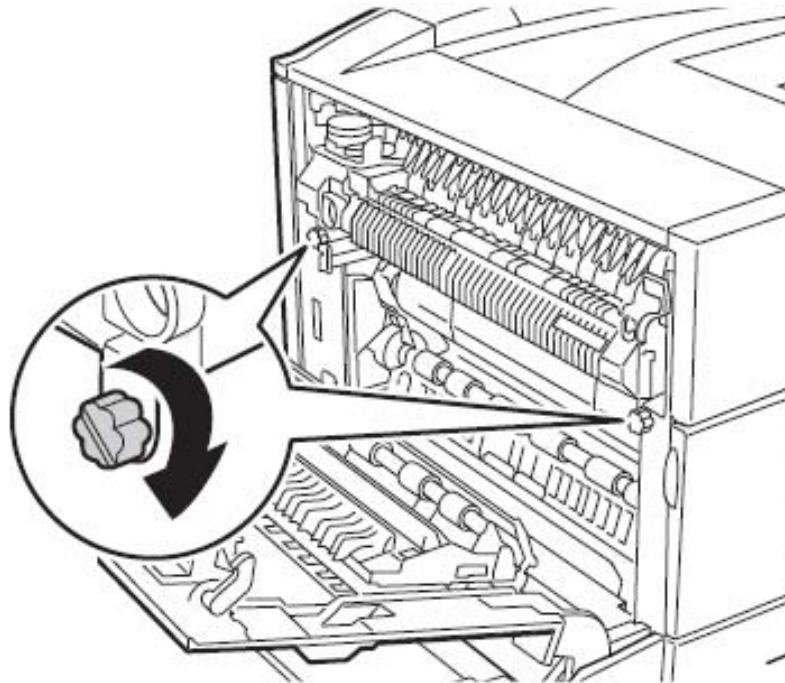

Fig. 6.2.m Carefully tighten the coloured thumbscrews

8. Close the printer side door (Door A).

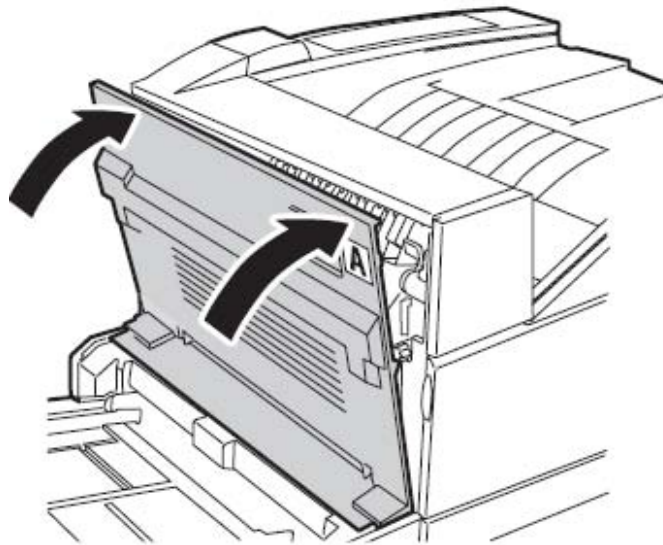

Fig. 6.2.n Closing printer door A



Together with the fuser, further items have to be replaced.
(See contents of the maintenance kit and figure 6.2.a, too.)



Make sure you follow the instructions given in the instruction sheet shipped with the maintenance kit.



7. Troubleshooting



When an error occurs, a corresponding error message is displayed in the control panel (see section 7.3).

Please address the problems described in this chapter yourself (especially the consumable replacement).

Please regard the following steps if a printer opening becomes necessary:



- During operation, components in the printer's interior will heat up. Make sure you do not burn your hands when you fix a paper jam.

- After closing the printer, make sure all covers are firmly shut.



Only a MICROPLEX authorized operator or service engineer should address printer problems for which no remedies are given in the following pages.

When reporting a problem to your service engineer, please give him the precise error message so that he can more quickly localize the error.



If an error message indicates a paper jam, a print repeat will be necessary.

The printer is provided with an automatic jam safety function to prevent a loss of data.

This function can be switched off if the user wants to resume the print job at a position he chooses himself (see section 5.6 Clearing the Input Buffer).

7.1. Error in the Print Process

<u>Defect</u>	<u>Remedies</u>
Printer does not work	<p>- Check the power supply, switch on the device.</p> <p>If your printer is not responding, first make sure:</p> <ul style="list-style-type: none"> • The power cord is plugged into the printer and a properly grounded electrical outlet. • The electrical outlet is not turned off by any switch or breaker. • Other electrical equipment plugged into the outlet is working. • The printer is turned on. • The printer cable is securely attached to the printer and the host computer, print server, option, or other network device. <p>Once you've checked each of these possibilities, turn the printer off and back on. This often fixes the problem.</p> <p>- Make sure all covers of the device (e.g. front cover) are completely closed.</p> <p>- Read any error messages in the control panel (see section 7.3).</p> <p>- Refill paper feeders with paper of suitable size (see chapter 3).</p>
Repeated paper jam	<p>- After any paper jam, make sure all the jammed paper has been removed completely from the paper paths.</p> <p>- Carefully read the information in section 7.4: Print Media Jam.</p>

If the remedies above are not successful please switch off the device and contact a MICROPLEX authorized service engineer.

7.2. Reduced Print Quality

<u>Defect</u>	<u>Remedies</u>
Printout too light	<ul style="list-style-type: none">- If the message [Toner Low] or the message [Toner Empty !] is displayed, replace the toner cartridge (see section 3.2: Toner Cartridge Replacing).- If the message [Drum Near End] or the message [Drum Cartr.Err] [J6-1, Life End] is displayed, replace the drum (see section 3.3: Drum Cartridge Replacing).- Do not use damp paper.- If you must print on special paper, please consider finding the most appropriate paper type.- Check the environmental conditions and change them if necessary. Make sure you know the admissible values for relative humidity, temperature etc.. See also section 2.4: Printer Installation.
Toner residues on the back side of the printouts	<ul style="list-style-type: none">- Clean the printer

If the remedies above are not successful, please contact a MICROPLEX authorized service engineer.

7.3. Error Messages

The following gives examples of warnings and error messages that can be displayed in the control panel of the SOLID 50 A3 - 3 (panel messages, see also section 4.3: Control Panel View).

By displaying the message in clear the device points to the reason for the error.

<u>Panel message</u>	<u>Description</u>	<u>Remedies</u>
e.g. [Cover Open [Door B]	Close Door B (see figure 7.4.4.a).
[Drum Cartr.Err. [J3-1, No Cartr.]	The drum cartridge has to be installed correctly (see section 3.3: Drum Cartridge Replacing).

7.3.1. Consumables Missing

<u>Panel message</u>	<u>Description</u>	<u>Remedies</u>
e.g. [Load Paper [Feeder 1]	Paper missing in feeder 1. Fill the empty paper feeder (see section 3.1: Print Media Handling).
[Format Error [DIN A5 missing]	No feeder contains paper with appropriate size. Refill paper or change the paper size setting (see section 3.1.4).
[Toner Low]	Warning.
[Toner Empty !]	The toner supply is under the minimum level. The toner cartridge has to be replaced (see section 3.2: Toner Cartridge Replacing).

<u>Panel message</u>	<u>Description</u>	<u>Remedies</u>
[Drum Near End]	Warning.	
[Drum Cartr.Err] [J6-1, Life End]	The drum is used up.	The drum cartridge has to be replaced (see section 3.3: Drum Cartridge Replacing).

7.3.2. Error in Paper Transport

<u>Panel message</u>	<u>Description</u>	<u>Remedies</u>
e.g. [Paper Tray Full !] [Paper Tray x]		Empty the paper tray.
[Paper Jam !] [C1-3, Tray 1]	Location of the paper jam	Remove the jammed paper in paper tray 1 (see section 7.4: Print Media Jam).

7.3.3. Service Call

<u>Panel message</u>	<u>Description</u>	<u>Remedies</u>
e.g. [Service Call] [SRxx = yy]	xx Status number yy Status value (hexadecimal)	Please give your service engineer the exact error message

7.4. Print Media Jam

By carefully selecting print media and loading them properly, you should be able to avoid most jams. See the following for instructions on loading print media.

7.4.1. Avoiding Jams

Storing print media

Use the following guidelines to avoid paper feeding problems and uneven print quality.

- Store print media in an environment where the temperature is approximately 21°C (70°F) and the relative humidity is 40%.
- Store cartons of paper on a pallet or shelf rather than directly on the floor.
- If you store individual packages of paper out of the original carton, make sure they rest on a flat surface so the edges do not buckle or curl.
- Do not place anything on top of paper packages.

Loading print media



Please regard the following information to avoid a paper jam:

- Check if the paper has been inserted correctly (see section 3.1).
- Check if the paper is impeccable (the paper must not be creased, damp, dirty or bent).
- Make sure the paper cassettes are not too full (regard the marks at the interior sides of the paper cassettes, see section 3.1.1).
- Check if the adjustable guides of the paper cassettes are adjusted right.
- If you must print on special paper:
Insert special paper into the multipurpose feeder
(comp. section 3.1.2: Loading the Multipurpose Feeder).
- Do not fill different kinds of paper into one cassette.
- The paper paths / paper cassettes must be opened and closed carefully.

7.4.2. Clearing Jams from the Printer

When a jam occurs, the printer displays a two-line **error message** and stops operating.

Example of an error message:

[Paper Jam !]	
[zzz, Fuser Area]	Location of the paper jam, in addition a error code is displayed.

Please regard the following information to remove a paper jam:



- Components inside the printer can be very hot, so please proceed carefully.
- The jammed material has to be removed very carefully from the printer.
- The sheets within all paper paths have to be removed completely.
- Close all printer covers duly.

In fig. 7.4.2.a the paper paths inside a SOLID 50 A3 - 3 printer are shown including some optional equipments. The current paper path depends on the selected paper cassette and the selected output stacker.

In case of paper jam you must clear all paper from the entire paper path.

The paper path is the route paper travels as it makes its way from the selected paper source through the printer and into the selected output bin. To clear the paper in the path, start at the paper source the printer is using for the current job. Open all doors and covers between the source and the selected output bin. If you are not sure which source the printer is using, start with cassette 4, if installed; otherwise, start with cassette 2. See the following illustrations for a better understanding of the path the paper travels through the printer and its options.

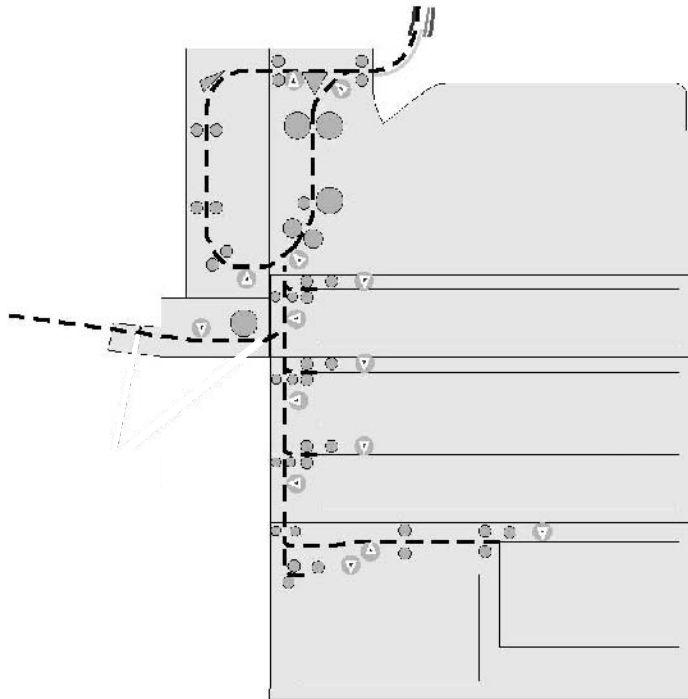

Fig. 7.4.2.a SOLID 50 A3 - 3 schematic paper path of standard cassettes and optional cassettes, duplex unit, and multipurpose feeder

You can use the message map on the front of the printer to locate the doors, covers, and options you must open or remove to clear the paper path.

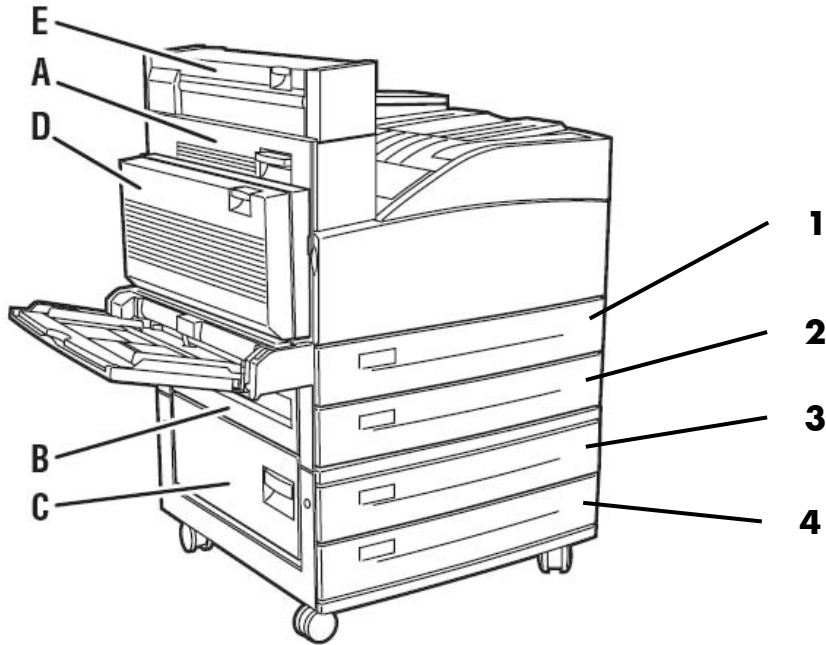

Fig. 7.4.2.b Illustration of areas where you can access jams

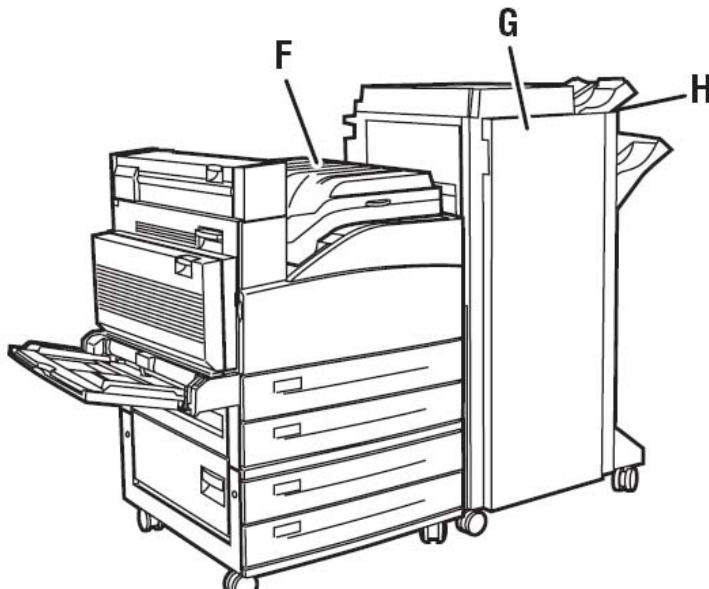

Fig. 7.4.2.c Printer together with the optional finisher/stacker

7.4.3. Clearing Jam inside Cassette 1 and the Toner Cartridge Area

Note: The following instructions are written assuming you are using the multipurpose feeder and the duplex unit. If you are using the envelope feeder, you must remove it before opening the duplex unit door.

1. Open the multipurpose feeder.

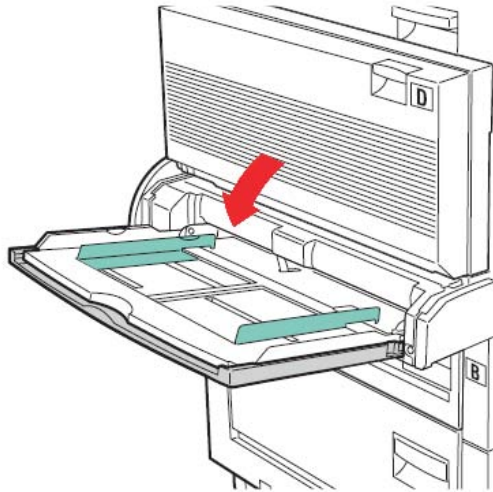

Fig. 7.4.3.a Opening the multipurpose feeder

2. Pull up on handle to open the printer side door (Door A).

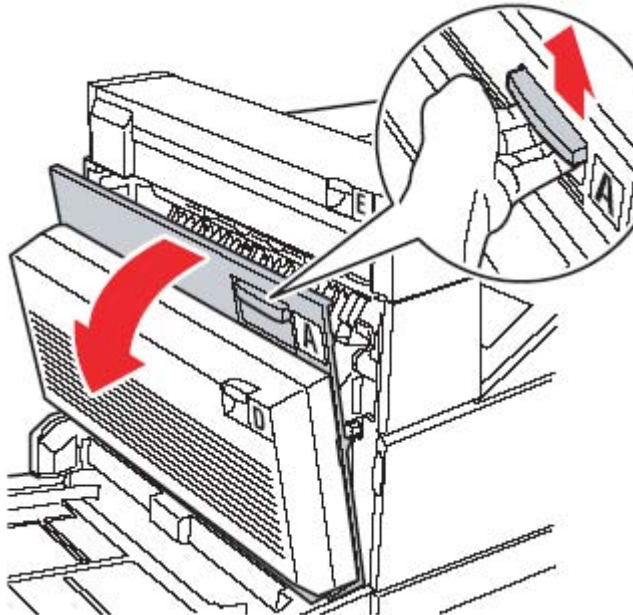

Fig. 7.4.3.b Opening the printer side door (Door A)

Warning: Some components inside Door A may be hot!

3. Remove the paper based on what part is visible.
 - If the paper is visible, pull it straight out and continue with **step 7** on the following page.
 - If the paper is not visible or there is not enough showing to grasp easily, it is still in the cassette. Complete **step 5** through **step 9**.
 - If the paper is not visible in the cassette, the paper is lodged behind the cassette and requires that you **remove the cassette**.

Pull the cassette completely out. Then pull the cassette straight up, and then out toward you. Set the cassette aside and pull the jammed paper straight out of the printer. Reinstall the cassette.

4. If necessary, press the green handle to move the paper to make it easier to remove.

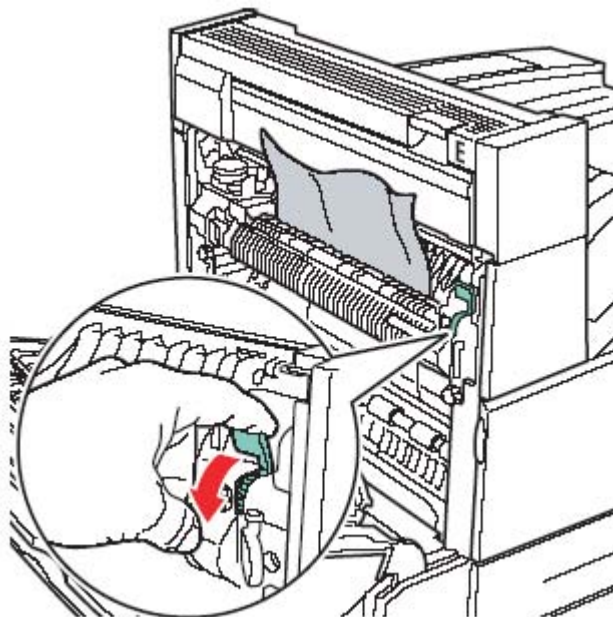

Fig. 7.4.3.c Removing jammed paper

5. Pull cassette 1 open.

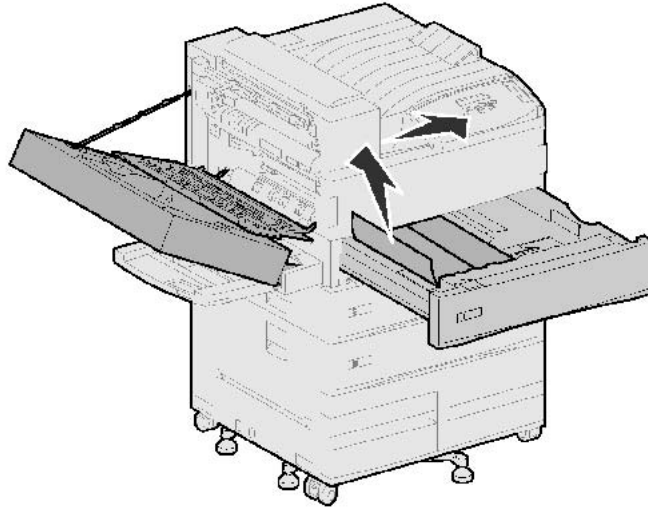

Fig. 7.4.3.d Removing jammed paper

6. Pull the paper to the right, and then straight out.
7. Confirm that all paper fragments are removed.
8. Close cassette 1.
9. Close the printer side door (Door A).

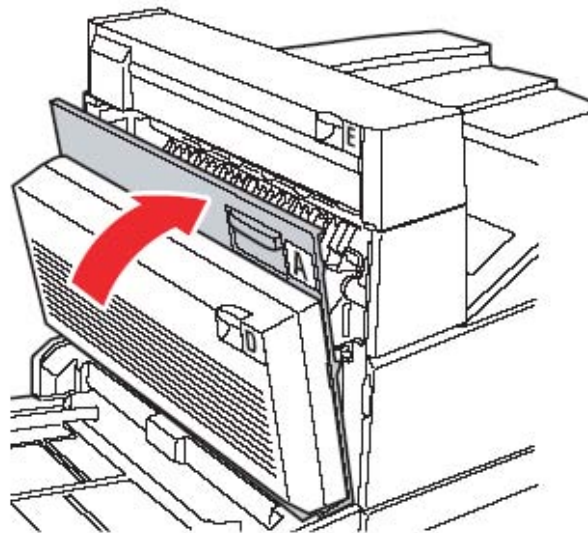

Fig. 7.4.3.e Closing the printer side door (Door A)

7.4.4. Clearing Jam inside Cassette 2

1. Pull up on handle to open the cassette 2 side door (Door B).

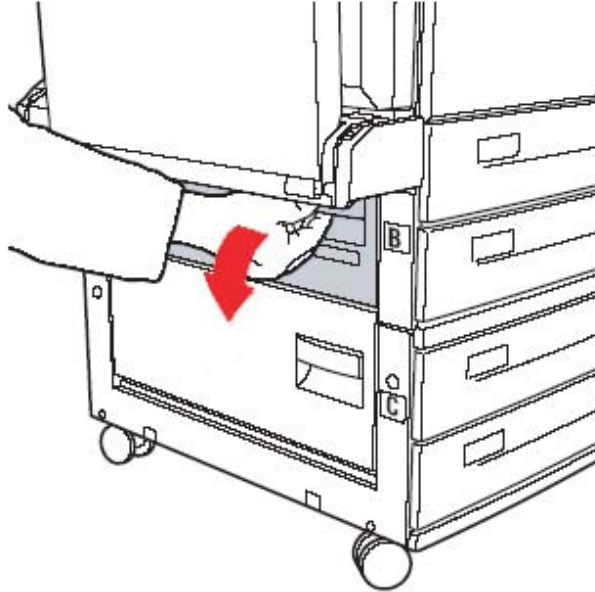

Fig. 7.4.4.a Opening the cassette 2 side door (Door B)

2. Remove the paper as follows:
 - If the paper is visible, pull it straight out and continue with **step 5**.

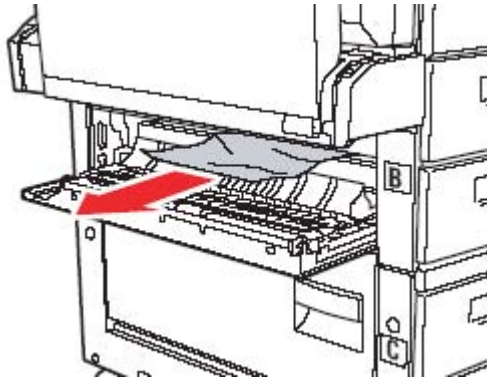

Fig. 7.4.4.b Removing the paper

- If the paper is not visible or there is not enough showing to grasp easily, it is still in the cassette. Complete **step 3** through **step 6**.

- If the paper is not visible in the cassette, the paper is lodged behind the cassette and requires that you **remove the cassette**. Pull the cassette completely out. Then pull the cassette straight up, and then out toward you. Set the cassette aside and pull the jammed paper straight out of the printer. Reinstall the cassette.

3. Pull cassette 2 open.

4. Pull the paper to the right, and then straight out.

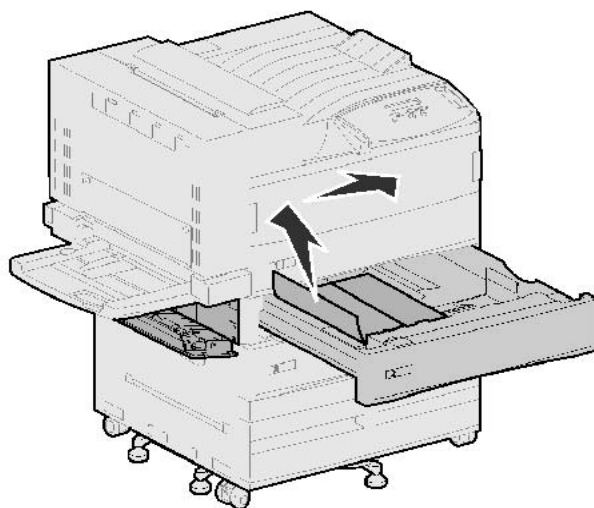

Fig. 7.4.4.c Pulling out the jammed paper

5. Close cassette 2.
6. Close the cassette 2 side door (Door B).

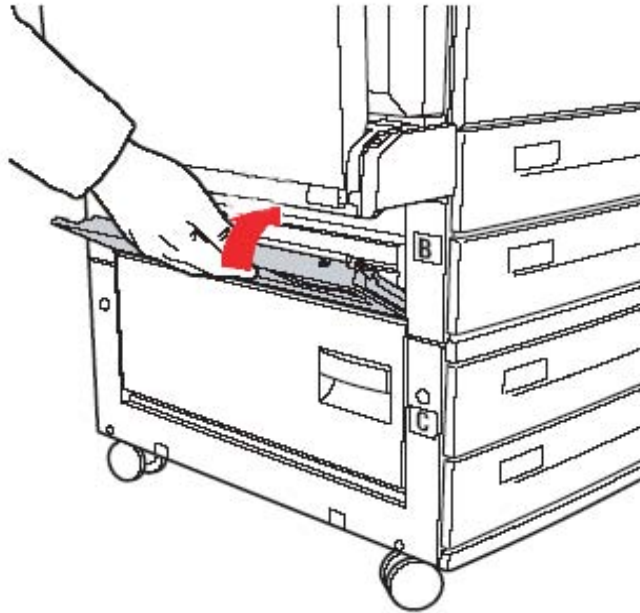

Fig. 7.4.4.d Closing door B

7.4.5. Clearing Jam inside Cassette 3 and Cassette 4

1. Open the side door of cassettes 3 and 4 (Door C).

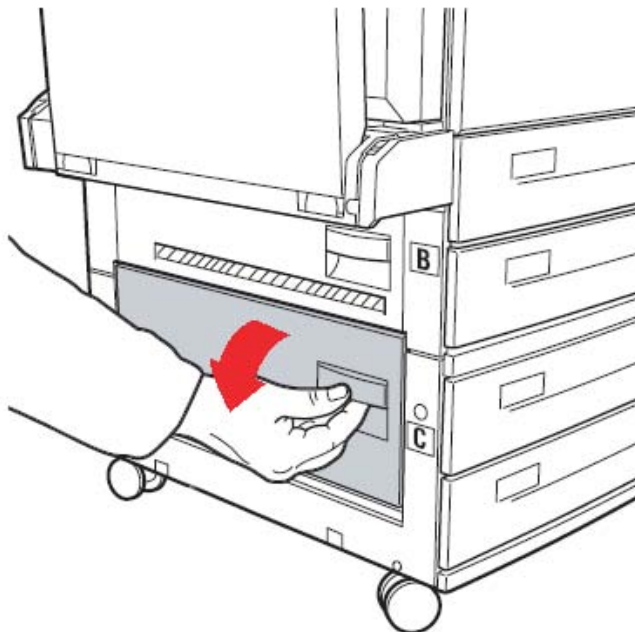

Fig. 7.4.5.a Opening door C

2. Remove the paper as follows:
 - If the paper is visible, pull it straight out and continue with **step 6**.

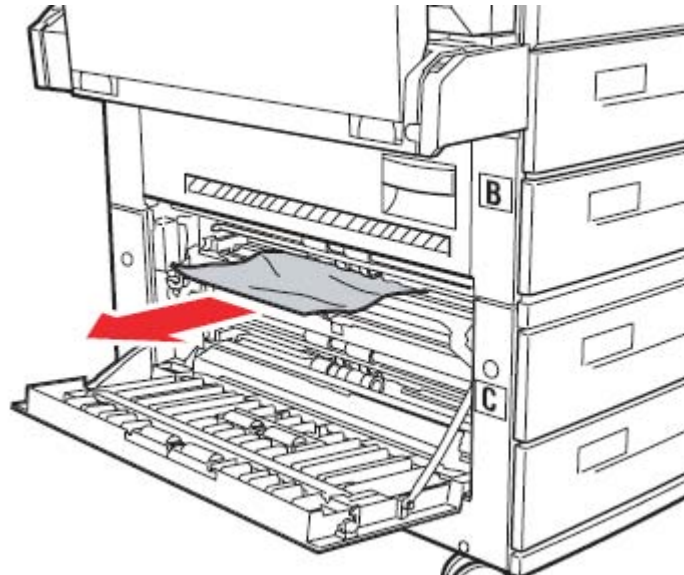

Fig. 7.4.5.b Removing the paper

- If the paper is not visible or there is not enough showing to grasp easily, it is still in the cassette. Complete **step 3** through **step 6**.
 - If the paper is not visible in the cassette, the paper is lodged behind the cassette and requires that you **remove the cassette**. Pull the cassette completely out. Push down the tab on the left side of the cassette, pull the cassette straight up, and then out toward you. Set the cassette aside and pull the jammed paper straight out of the printer. Reinstall the cassette.
3. Pull cassette 3 (or cassette 4) open.
 4. Pull the paper to the right, and then straight out.
 5. Close cassette 3 (or cassette 4).
 6. Close the side door for cassettes 3 and 4 (Door C).

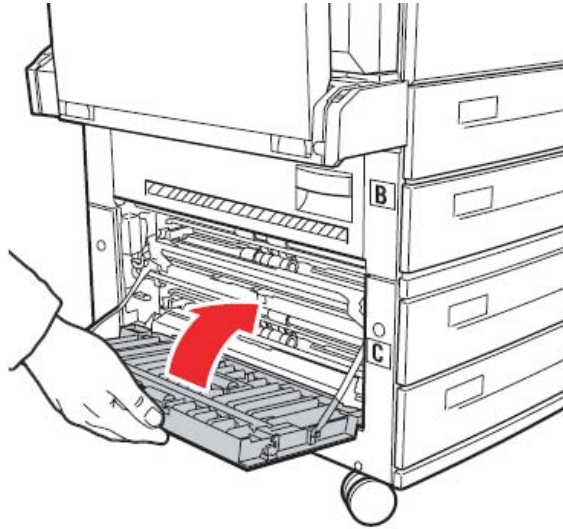

Fig. 7.4.5.c Closing door C

7.4.6. Clearing Jam inside the Multipurpose feeder

Print media may jam in one of three locations in the multipurpose feeder. Remove the jam based on the print media location:

If print media jams as it begins to move from multipurpose feeder into the printer, pull the sheet straight out.

If print media jams after it enters the printer from the multipurpose feeder:

1. Push up on the latch to release the printer side door (Door A; compare figure 7.4.3.b).
2. Gently lower the door to the open position.
3. Pull the sheet straight out.

If the sheet is too short to grasp:

- Close the printer side door (Door A).
The printer automatically cycles, forcing the sheet to move forward.
- Open the printer side door (Door A).
- Pull the sheet straight out.

4. Close the printer side door (Door A).

7.4.7. Clearing Jam inside the Duplex Unit

1. Pull up on handle to open the duplex unit (Door D).

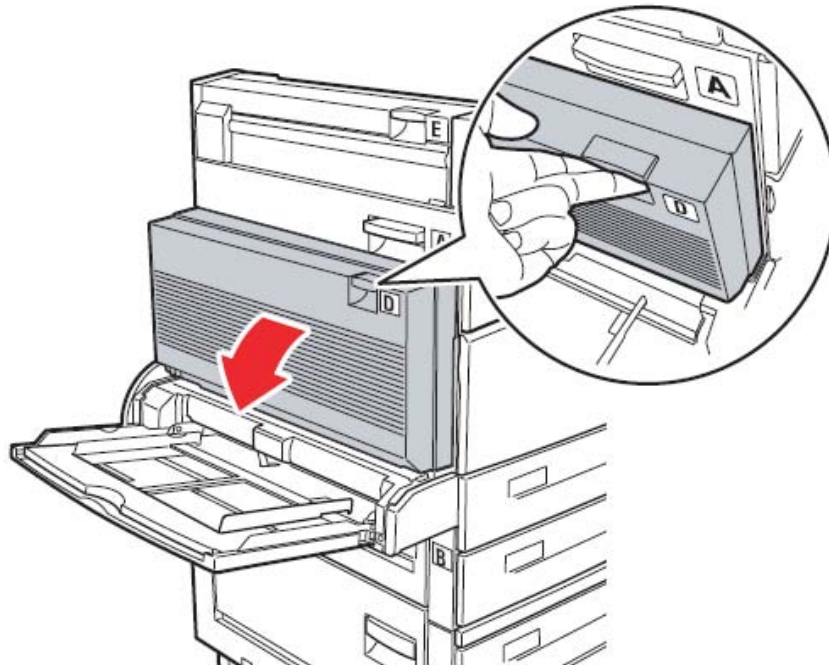

Fig. 7.4.7.a Opening the door D

2. Pull the sheet straight out.

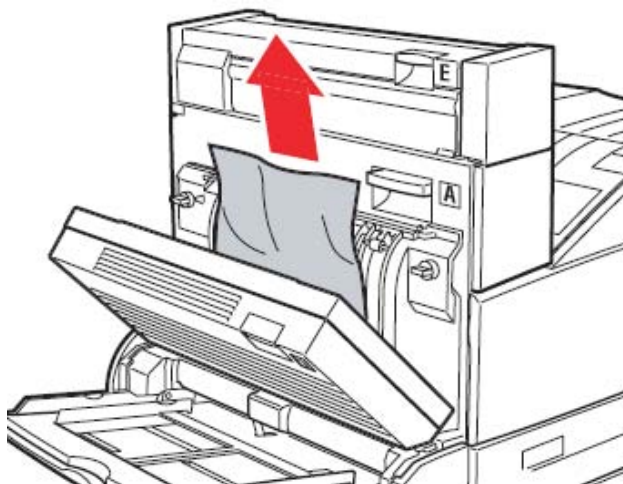

Fig. 7.4.7.b Removing the paper

If the paper is not visible or there is not enough showing to grasp easily, it is already behind door E.

3. Pull up on handle to open door E.

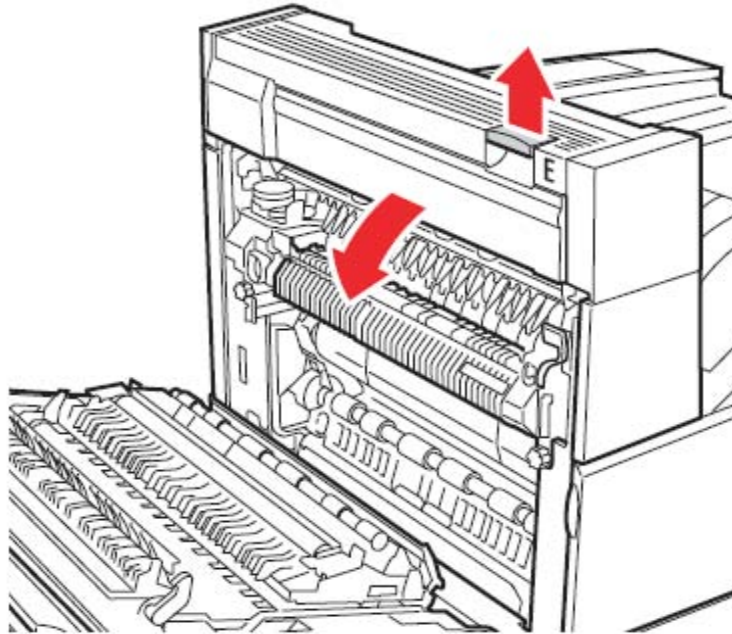

Fig. 7.4.7.c Opening the door E

4. Pull the sheet straight out.

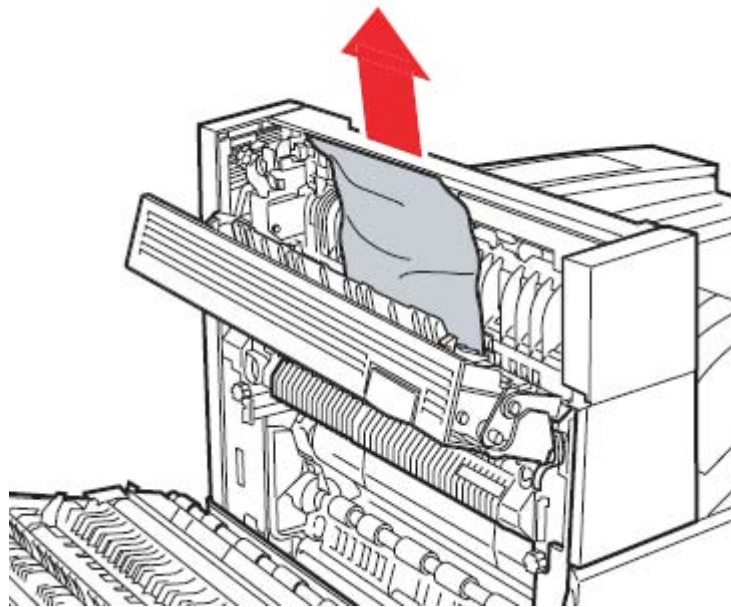

Fig. 7.4.7.d Removing the paper

5. Close door E.

6. Close the duplex unit door (Door D).

7.4.8. Solving Paper Feed Problems

<u>Symptom</u>	<u>Cause</u>	<u>Solution</u>
Paper frequently jams in the printer	You are using print media that does not meet the printer specifications.	Use recommended paper and other print media. Do not load wrinkled, creased, or damp paper. Flex, fan, and straighten paper before you load it.
	You have loaded too much paper or too many envelopes.	Make sure the stack of print media you load does not exceed the maximum stack height indicated at the back of the cassette or on the multipurpose feeder.
	The guides in the selected cassette are not set to the appropriate position for the size print media loaded.	Move the guides in the cassette to the correct position. See section 3.1: Print Media Handling for detailed instructions.
	Paper has absorbed moisture due to high humidity.	Load paper from a fresh package. Store paper in its original wrapper until you load it.

<u>Symptom</u>	<u>Cause</u>	<u>Solution</u>
Paper frequently jams in the printer		Push all cassettes firmly into the printer after loading them. Do not load print media in a cassette while a job is printing by selecting print media from this same cassette.
	The specified output bin is full.	Remove the stack of paper from the output bin as indicated by the operator panel message, and then press ON LINE.
	The paper pick rollers are dirty or worn.	The pick rollers have to be replaced.
Paper frequently jams in the optional mailbox or optional finisher	We recommend that transparencies, labels, card stock, and envelopes not be sent to the optional mailbox or optional finisher.	These print media types should be sent to the standard bin.
The Paper Jam message remains after you remove the jammed print media.	You have not cleared the entire paper path, or you did not open the door to check for jams in this area.	Open the printer doors, clear print media from the entire paper path, and close the doors.

If the remedies above are not successful or there is an error message that is not described in the sections above please switch off the device and contact a MICROPLEX authorized service engineer.

7.5. Print Repeat after an Error

The printer is provided with an automatic jam safety function to prevent a loss of data.

As a standard all the pages being within the printer when an error occurs will be printed again, no data will get lost.

The exact number of pages to repeat depends on the format length and the position where the error occurred on the page.

This automatic jam safety function can be switched off (by changing the EEPROM - configuration) if the user wants to resume the print job at a position he chooses himself.

In addition to this see panel function Clearing the Input Buffer (section 5.6).

8. Measures for Transport and Shipping (Repacking)

The Printer is shipped with special packing material and fixing measures. It is recommended to store the boxes and those packing materials.



In case of further shipping or returning of the products they must be repacked in the original way in order to avoid damaging during transportation.

The following list gives you an overview of the working steps necessary for repacking. Pay attention to the notices located on the products and the hints given in the Service Manual as well.



If you are not familiar with any of the working steps please ask your service engineer or your supplier.

- Remove the printer's optional devices (f.e.: feeder, stacker, cassettes ...).
- Remove the Toner Cartridge.
Put the Toner Cartridge into its original box.
- Remove the Drum Cartridge.
Put the Drum Cartridge into its original box.
- Lock all moveable parts of the printer (use all original transport safety devices, adhesive fasteners and so on).

Repack all items in their original packing material and ship them in the original boxes.



9. Specifications

Print technology:	non-impact, Laser, OPC, heat pressure fusing	
Print speed:	up to 50 pages/min A4	
Resolution:	300 / 600 dpi (dots per inch, horizontal and vertical)	
Paper size:	A5 up to A3 (non standard page length and paper width configurable); A6 via manual input only	
Paper weight:	64 to 163 g/m ² ; duplex printing up to 120 g/m ² ;	
Paper feed:	500 sheets of 20 lb paper (Standard Cassette 1) 500 sheets of 20 lb paper (Standard Cassette 2) 2,000 sheets of 20 lb paper (Optional High Capacity Feeder) 100 sheets (A6 up to A3 via manual input) +either 500 sheets each (A5 up to A3; optional cassettes 3 + 4) or 1200 sheets (A4; cassette 3) 800 sheets (A4; cassette 4)	
Stacker:	up to 500 sheets face down (standard) up to 100 sheets face up (optional) 3,500 sheets Finisher/Stacker (optional)	
Interfaces:	parallel: IEEE 1284 (Centronics), (MP-BUS, SPS-Control, optional) serial: RS232/RS422 (Jumper) USB 1.1 LAN: Ethernet 10/100 Mbit (TCP-IP) Optional: LAN: Ethernet (SPX-IPX, LAT), Token Ring Host: IBM SCS / IPDS (Twinax/Coax), Siemens (BAM/SS-97)	

Resumption see next page!

Size: (the measurements only include the standard cassettes (see above))

width: appr. 640 mm (25.2 in.)

depth: appr. 525 mm (20.7 in.)

height: appr. 577 mm (22.7 in.)

Weight: appr. 48 kg (106 lbs) inclusive consumables

Environment: Temperature: +5 to +32 °C
+41 to +90 °F
Rel. atmospheric humidity: 15 to 85 %

Mains connection: AC 120 V / 60 Hz North America
AC 230 V \pm 10% / 50 Hz Europe, United Kingdom

Power admission: max. 1.5 kVA

Costs per Page for MICROPLEX Print Systems

The term "costs per page" is the most frequently used one in connection with the purchase of a printer. Nevertheless this term is the one with the biggest lack of definition.

The distributors normally attach great importance to having small values for the costs per page. The user normally wants to have a value that is as realistic as possible.

There isn't any generally valid rule to calculate the costs per page. Therefore values given by different manufacturers are very often not comparable.

The values given by MICROPLEX are based on the utilization time of the so-called consumables of the printer. There isn't any generally valid rule for this calculation, either. Therefore MICROPLEX has fixed the definition of consumables as follows:

1. Consumables

Consumables are parts or substances which the user can exchange or refill without tools.

MICROPLEX understands by this definition that the user can decide by visible criteria when he should exchange or refill consumables. The working steps can be done by the user in accordance with the manual without the usage of tools.

Consumables can be different depending on the printer type. The most important consumable for example is **toner**.

Usually the utilization time of these materials is given as a number of pages (DIN A4). These values often refer to the print density (3%, 4%, or 5%) which is given as an application specific parameter.

Usually a value of 5% print density is defined, very seldom is 4% used.

In the case of a low print density (e.g. 3%) the utilization time increases, in the case of a high print density (e.g. 10%) the utilization time is decreased.

Therefore the utilization time is strongly dependant upon the application.

Experience proves that in professional applications a print density of higher than 5% is usually reached. For a delivery note containing a form and some bar codes a print density of 8 - 10% is quite normal.

There are further parts that must be exchanged in addition to the consumables during the life time of a print system. MICROPLEX divides these additional parts into two categories:

2. Application specific wearing materials

Application specific wearing materials are parts which have to be exchanged by a service engineer or a trained operator. The criterias for the exchange aren't always easily recognizable for a user. Some of the criterias require measuring techniques or the experience of a service engineer or operator.

In a normal application, parts of this category are:

- fuser unit
- process unit (drum, OPC)
- ozone filter

3. Spare parts

Spare parts are exchanged by the service engineer, when they fail.

Examples for spare parts are:

- couplings
- electronic assemblies
- rollers

Depending on the application some parts may change categories under certain circumstances. If for example very rough paper is used, the rollers can become an (application specific) wearing part.

It's a fact, that the right time to exchange a component depends not only on the failure of a component but also on a possible loss of print quality in the printouts.

MNPSQ = Mean Number of Prints with Specified Quality (**SQ**).

This value is often associated with "Lifetime". This term is not correct. MNPSQ describes the period of time in which a defined print quality is maintained.

The print quality is determined by the values for

- print density
- background darkness
- homogeneity

The value **IQ** (Initial Quality) is used to designate the print quality that is reached with a new printer.

CAQ (Customer Acceptable Quality) is a purely subjective lower limit which a respective customer is willing to accept the print quality. An exchange of parts is only then necessary even if the MNPSQ is already exceeded.

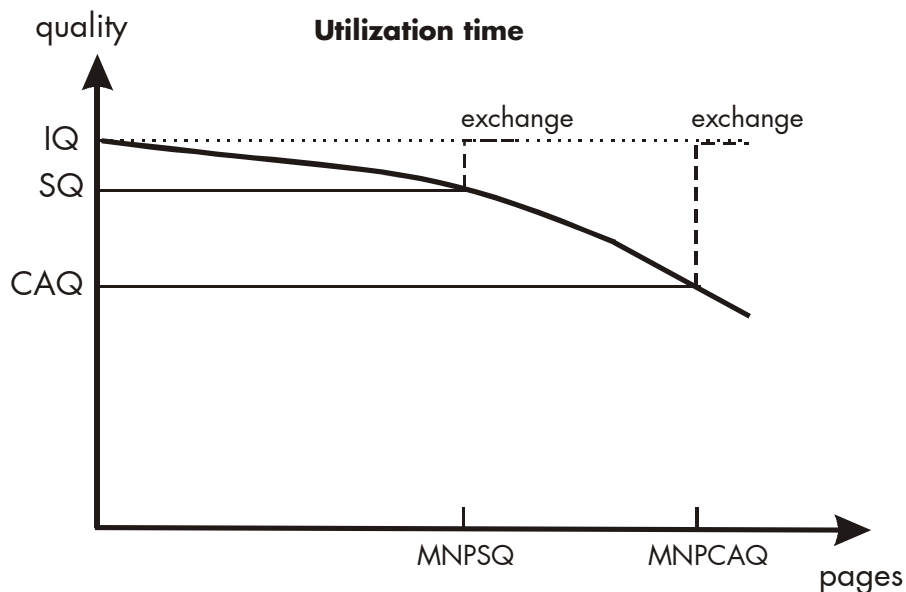

10. Index

A

ARROW keys 67

C

cancel job 78
CANCEL key 63
cassettes 30, 32
CE - conformity 10
character spacing 108
characters per inch 108
check list 13
cleaning 113
clearing jams 132
configuration 64, 71
connect, printer to a PC 59
consumables 32, 128, 153
contents, table of 3
contrast 109
control panel 30, 31, 61, 64
control panel elements 62
conventions 9
costs per page 153

D

data - LED 62
data interface 90
density 109
description, general 7
diagrams 70
dimensions 28
display 61, 62
display language 93
door A 30
door F 30
drum cartridge 51
duplex 85

E

emergency power-off 12
emulation 91
environment 28, 152
Error - LED 62
error message 125, 128, 132
extended menu 65

F

factory default 96
feed problems, solving of 145
feeder linking 82
feeder, selection 81
filling level, cassettes 35
font bank 72
Font List 73
font number 97
font selection 97
fonts 75
FORM FEED 77
format check 88
front cover 30
fundamentals 8
fuser, replacing 114

H

Hexdump 76
humidity 28

I

image shifting 103, 105
INFO key 63, 66, 68
input buffer 78, 95
installation 13
interface 90, 151
interface, connection 26
interfaces 31
introduction 7
IP address 110

J

jam access door 30
jams, avoiding of 130

K

keys 61

L

laser notice 10
line spacing 107
lines per inch 107

M

mains connection 152
margins 102
measures, transport 149
memory distribution 95
MENU key 63, 68, 69
menu page 79
menu structure 65
multipurpose feeder 30
multipurpose feeder, loading 38

N

network parameters 110
NEXT key 63, 66, 67
normal print 77

O

ON LINE - LED 62
ON LINE key 61, 63, 66, 69
operator maintenance 113
output bin 41

P

packing materials 13, 16
panel 61
panel display 70
panel functions 71, 79
panel keys 63, 66, 70
paper feed 151
paper handling 32
paper inserting 32
paper jam 125, 130
paper path 133
paper size 42, 87, 151
paper weight 151
permanent configuration changes 64, 68
power admission 152
power source 26
power switch 30, 31
preparations 17
PREVIOUS key 63, 66, 67
print density 154
print direction 89
print media handling 32
print media jam 130

print media, loading 131
print media, storing of 130
print mode 85
print quality 127, 154
print repeat 125, 147
print resolution 74
print speed 151
printer components 30
printer installation 26

R

reduced menu 65
relative atmospheric humidity 28, 152
repacking 149
required space 28
resolution 7, 74, 151
RETURN key 63, 67, 69
returning 149

S

safety instructions 10
SELECT key 63, 66, 67
service call 129
shipping 149
simplex 85
size 152
size sensing 88
sliding pattern 80
spare parts 154
specifications 151
stacker 151
stacker, selection 83
standard output bin 30, 41
START/STOP key 63, 66
STATUS key 63
status sheet 71
symbol 9
symbol code 101

T

temperature 28, 152
test prints 80
text margins 102
text orientation 100
toner cartridge 44
transfer roller 114
transparent code 94
transport 149
transport damages 13
troubleshooting 125

U

unpacking 14
utilization time 153

V

voltage 152

W

warnings 128
weight 152