



Service Manual

Lexmark Forms Printer 2400 Series

24XX-100

- ***Table of Contents***
- ***Start Diagnostics***
- ***Safety and Notices***
- ***Trademarks***
- ***Index***
- ***Manuals Menu***

LEXMARK[™]

Lexmark and Lexmark with diamond design are trademarks of Lexmark International, Inc., registered in the United States and/or other countries.

24xx

Edition: November 2000

The following paragraph does not apply to any country where such provisions are inconsistent with local law: LEXMARK INTERNATIONAL, INC. PROVIDES THIS PUBLICATION "AS IS" WITHOUT WARRANTY OF ANY KIND, EITHER EXPRESS OR IMPLIED, INCLUDING, BUT NOT LIMITED TO, THE IMPLIED WARRANTIES OF MERCHANTABILITY OR FITNESS FOR A PARTICULAR PURPOSE. Some states do not allow disclaimer of express or implied warranties in certain transactions; therefore, this statement may not apply to you.

This publication could include technical inaccuracies or typographical errors. Changes are periodically made to the information herein; these changes will be incorporated in later editions. Improvements or changes in the products or the programs described may be made at any time.

Comments may be addressed to Lexmark International, Inc., Department D22A/032-2, 740 West New Circle Road, Lexington, Kentucky 40550, U.S.A or e-mail at ServiceInfoAndTraining@Lexmark.com. Lexmark may use or distribute any of the information you supply in any way it believes appropriate without incurring any obligation to you. You can purchase additional copies of publications related to this product by calling 1-800-553-9727. In other countries, contact your point of purchase.

Lexmark and Lexmark with diamond design are trademarks of Lexmark International, Inc., registered in the United States and/or other countries.

Other trademarks are the property of their respective owners.

© Copyright Lexmark International, Inc. 2000.

All rights reserved.

UNITED STATES GOVERNMENT RESTRICTED RIGHTS

This software and documentation are provided with RESTRICTED RIGHTS. Use, duplication or disclosure by the Government is subject to restrictions as set forth in subparagraph (c)(1)(ii) of the Rights in Technical Data and Computer Software clause at DFARS 252.227-7013 and in applicable FAR provisions: Lexmark International, Inc., Lexington, KY 40550.

U.S.A. P/N: 12G3662

Table of Contents

Safety Information	vii
Preface	xii
General Information	1-1
Printer Specifications	1-1
Printer Speeds	1-1
Setup Mode	1-2
Entering Setup Mode	1-2
Exiting Setup Mode	1-2
Setup Menu Options	1-3
Interface Menu Options	1-3
Setting The Tear Off Position	1-4
Setting Top-Of-Form (Continuous - Pull Mode)	1-5
Setting Top-Of-Form (Cut Forms - Envelopes)	1-5
Options	1-6
Diagnostic Information	2-1
Start	2-1
Voltage, Ground, And Continuity Readings	2-1
Error Indication Table	2-2
Symptom Check Table	2-5
Irrecoverable Operator Errors	2-12
Service Checks	2-13
Abnormal Noise Service Check	2-13
Auto Sheet Feeder (ASF) Service Check	2-14
Carrier Service Check	2-16
Intermittent Problem Service Check	2-18
No Print or Abnormal Print Service Check	2-21
Operator Panel Service Check	2-21
Paper Present Sensor Service Check	2-22
Paper Feed Service Check	2-23
Paper Select Sensor Service Check	2-25
POST Service Check	2-26
Power Service Check	2-27
Print Speed Service Check	2-28
Printhead Service Check	2-29
Pull Tractor Sensor Service Check	2-31
Top-Of-Forms Service Check	2-32
Tractor 2 Service Check	2-33

Diagnostic Aids	3-1
Power-On Self Test (POST)	3-2
Print Test	3-3
Hex Trace Mode	3-4
Printer Default Settings	3-5
U.S. Defaults	3-5
World Trade Defaults	3-5
Clearing Paper Jams	3-6
Cut Sheet Jams	3-6
Continuous Forms Jams	3-6
Repair Information	4-1
Handling ESD-Sensitive Parts	4-1
Adjustments	4-2
Printhead-to-Platen Gap Adjustment	4-2
Bidirectional Print Adjustment	4-4
Removal Procedures	4-5
Covers, Removals	4-5
Covers, Front Removal	4-6
Covers, Ribbon Access Removal	4-6
Covers, Option Removal	4-7
Covers, Top Removal	4-8
Covers, Operator Panel Assembly Removal	4-11
Covers, Bottom Removal	4-12
Electronics Removals	4-13
EPROM Removal	4-13
Logic Board Removal	4-14
Power Supply Removal	4-15
Carrier Removals	4-16
Carrier Removal	4-16
Carrier, Motor Assembly Removal	4-21
Paper Handling Removals	4-24
Paper Select Lever Removal	4-24
Paper Feed Motor Removal	4-24
Form Thickness Lever Removal	4-25
Print Handling Removals	4-26
Platen Removal	4-26
Printhead Removal	4-27
Printhead Cables Removal	4-27
Print Unit Removal	4-28
Ribbon Drive Rack Gear Removal	4-30
Gears Removals	4-31
Left Side Gears Removal	4-31

Right Side Gears, Sub Frame Removal	4-34
Rollers Removals	4-36
Roller, Upper Feed Removal	4-36
Roller, Lower Pinch Removal	4-38
Roller, Lower Feed Removal	4-41
Sensors Removals	4-43
Sensor, Pull Tractor Removal	4-44
Sensor, Head Gap Removal	4-44
Sensor, Top-Of-Form Removal	4-44
Sensor, Paper Select Removal	4-45
Sensor, Paper Present Removal	4-45
Flags, Paper Present / Top-Of-Form Removal	4-45
Sensor, Home Position Sensor Removal	4-46
Options Removals	4-47
Auto Sheet Feeder Gears Removal	4-47
Auto Sheet Feeder Pick-up Roller Removal	4-48
Connector Locations	5-1
Signal Connections	5-2
Power Supply (9w & 24w)	5-2
Logic Board - Parallel Interface Cable (9w & 24w)	5-4
Logic Board - Serial Board (9w & 24w)	5-6
Logic Board - USB Cable (9w & 24w)	5-8
Logic Board - DC Power (9w & 24w)	5-8
Logic Board - Printhead (9w)	5-10
Logic Board - Printhead (24w)	5-12
Logic Board - Printhead (24w)	5-14
Logic Board - Gap Set Sensor (9w & 24w)	5-16
Logic Board - Home Position Sensor (9w & 24w)	5-16
Logic Board - Paper Present Sensor (9w & 24w)	5-16
Logic Board - Paper Select Sensor (9w & 24w)	5-18
Logic Board - Pull Tractor Sensor (9w & 24w)	5-18
Logic Board - Top Of Form Sensor (9w & 24w)	5-18
Logic Board - Carrier Motor (9w & 24w)	5-20
Logic Board - Paper Feed Motor (9w & 24w)	5-20
Logic Board - Operator Panel (9w & 24w)	5-22
Logic Board - Dual Tractor Cable (9w & 24w)	5-24
Serial Board - Serial Cable (9w & 24w)	5-25
Tractor 2 Cable Connectors	5-26

Preventive Maintenance	6-1
Lubrication	6-1
Lubrication Points	6-2
Lubrication Points (Oil)	6-3
Lubrication Points (Grease).....	6-4
Parts Catalog	7-1
How To Use This Parts Catalog	7-1
Assembly 1: Covers	7-2
Assembly 2: Carrier / Paper Feed Right Side	7-6
Assembly 3: Carrier / Paper Feed Left Side	7-10
Assembly 4: Electronics	7-14
Assembly 5: ASF - Roller / Support	7-16
Assembly 6: ASF - Side Frame / Covers	7-18
Assembly 7: Tractor 2 Option	7-20
Coax / Twinax Adapter	7-22
Index	I-1

Safety Information

- This product is designed, tested and approved to meet strict global safety standards with the use of specific Lexmark components. The safety features of some parts may not always be obvious. Lexmark is not responsible for the use of other replacement parts.
- The maintenance information for this product has been prepared for use by a professional service person and is not intended to be used by others.
- There may be an increased risk of electric shock and personal injury during disassembly and servicing of this product. Professional service personnel should understand this and take necessary precautions.

Consignes de Sécurité

- Ce produit a été conçu, testé et approuvé pour respecter les normes strictes de sécurité globale lors de l'utilisation de composants Lexmark spécifiques. Les caractéristiques de sécurité de certains éléments ne sont pas toujours évidentes. Lexmark ne peut être tenu responsable de l'utilisation d'autres pièces de rechange.
- Les consignes d'entretien et de réparation de ce produit s'adressent uniquement à un personnel de maintenance qualifié.
- Le démontage et l'entretien de ce produit pouvant présenter certains risques électriques, le personnel d'entretien qualifié devra prendre toutes les précautions nécessaires.

Norme di sicurezza

- Il prodotto è stato progettato, testato e approvato in conformità a severi standard di sicurezza e per l'utilizzo con componenti Lexmark specifici. Le caratteristiche di sicurezza di alcune parti non sempre sono di immediata comprensione. Lexmark non è responsabile per l'utilizzo di parti di ricambio di altri produttori.
- Le informazioni riguardanti la manutenzione di questo prodotto sono indirizzate soltanto al personale di assistenza autorizzato.
- Durante lo smontaggio e la manutenzione di questo prodotto, il rischio di subire scosse elettriche e danni alla persona è più elevato. Il personale di assistenza autorizzato, deve, quindi, adottare le precauzioni necessarie.

Sicherheitshinweise

- Dieses Produkt und die zugehörigen Komponenten wurden entworfen und getestet, um beim Einsatz die weltweit gültigen Sicherheitsanforderungen zu erfüllen. Die sicherheitsrelevanten Funktionen der Bauteile und Optionen sind nicht immer offensichtlich. Sofern Teile eingesetzt werden, die nicht von Lexmark sind, wird von Lexmark keinerlei Verantwortung oder Haftung für dieses Produkt übernommen.
- Die Wartungsinformationen für dieses Produkt sind ausschließlich für die Verwendung durch einen Wartungsfachmann bestimmt.
- Während des Auseinandernehmens und der Wartung des Geräts besteht ein zusätzliches Risiko eines elektrischen Schlags und körperlicher Verletzung. Das zuständige Fachpersonal sollte entsprechende Vorsichtsmaßnahmen treffen.

Pautas de Seguridad

- Este producto se ha diseñado, verificado y aprobado para cumplir los más estrictos estándares de seguridad global usando los componentes específicos de Lexmark. Puede que las características de seguridad de algunas piezas no sean siempre evidentes. Lexmark no se hace responsable del uso de otras piezas de recambio.
- La información sobre el mantenimiento de este producto está dirigida exclusivamente al personal cualificado de mantenimiento.
- Existe mayor riesgo de descarga eléctrica y de daños personales durante el desmontaje y la reparación de la máquina. El personal cualificado debe ser consciente de este peligro y tomar las precauciones necesarias.

Informações de Segurança

- Este produto foi concebido, testado e aprovado para satisfazer os padrões globais de segurança na utilização de componentes específicos da Lexmark. As funções de segurança de alguns dos componentes podem não ser sempre óbvias. A Lexmark não é responsável pela utilização de outros componentes de substituição.
- As informações de segurança relativas a este produto destinam-se a profissionais destes serviços e não devem ser utilizadas por outras pessoas.
- Risco de choques eléctricos e ferimentos graves durante a desmontagem e manutenção deste produto. Os profissionais destes serviços devem estar avisados deste facto e tomar os cuidados necessários.

Informació de Seguretat

- Aquest producte està dissenyat, comprovat i aprovat per tal d'acomplir les estrictes normes de seguretat globals amb la utilització de components específics de Lexmark. Les característiques de seguretat d'algunes peces pot ser que no sempre siguin òbvies. Lexmark no es responsabilitza de l'us d'altres peces de recanvi.
- La informació pel manteniment d'aquest producte està orientada exclusivament a professionals i no està destinada a ningú que no ho sigui.
- El risc de xoc elèctric i de danys personals pot augmentar durant el procés de desmuntatge i de servei d'aquest producte. El personal professional ha d'estar-ne assabentat i prendre les mesures convenients.

安全资讯

- 本产品使用特有的 Lexmark 元件，并依照严格的世界安全标准来设计、测试及验证。有些零件的安全功能可能不明显。对于其他厂牌更换零件的使用，Lexmark 概不负责。
- 本产品的维护资讯仅供专业服务人员使用，而非针对一般使用者。
- 本产品在拆卸、维修的时候，遭受电击或人员受伤的危险性会增高，专业服务人员对这点必须有所了解，并采取必要的预防措施。

안전 사항

- 본 제품은 특정 Lexmark 구성 요소의 사용에 있어 엄격한 세계 안전 표준에 맞도록 설계, 테스트되었으며 승인받았습니다. 일부 부품의 안전성은 항상 보장되지 않습니다. Lexmark는 다른 교체 부품의 사용에 대한 책임을 지지 않습니다.
- 본 제품에 관한 유지 보수 설명서는 전문 서비스 기술자용으로 작성된 것이므로 비 전문가가 사용할 수 없습니다.
- 본 제품을 해체하거나 정비할 경우 전기적인 충격을 받거나 상처를 입을 위험이 커집니다. 전문 서비스 기술자는 이 사실을 숙지하고 필요한 예방 조치를 취하도록 하십시오.

Preface

This manual is divided into the following chapters:

- “General Information” contains a general description of the printer and the maintenance approach used to repair it. Special tools and test equipment are listed in this chapter, as well as general environmental and safety instructions.
- “Diagnostic Information” contains error code table, symptom table, and service checks used to isolate failing field replaceable units (FRUs).
- “Diagnostic Aids” contains tests and checks used to locate or repeat symptoms of printer problems.
- “Repair Information” provides instructions for making printer adjustments and removing and installing FRUs.
- “Connector Locations” uses illustrations to identify the major components and test points on the printer.
- “Preventive Maintenance” contains lubrication specifications, and maintenance information to prevent problems and maintain optimum performance.
- “Parts Catalog” contains illustrations and part numbers for individual FRUs.

1. General Information

Printer Description

The Lexmark™ Forms Printer 248X-100 and 249X-100 are small versatile tabletop printers suitable for use in the home or small business. They are especially well-suited for applications that use continuous or multipart forms. The 2481 and 2491 are wide-carriage versions of the 2480 and 2490.

Printer Specifications

- Printhead life: 300 million characters
- Standard ribbon life: 4 million characters
- High yield ribbon life: 8 million characters
- Printer life: 5 Years
- Power consumption: 47 watts-maximum/7 watts idle

Printer Speeds

	9 Wire		24 Wire	
	10 cpi	12 cpi	10 cpi	12 cpi
Fast Draft	438 cps	510 cps	409 cps	465 cps
Draft	309 cps	304 cps	274 cps	328 cps
NLQ - Near Letter Quality	77.5 cps	77.5 cps	91.7 cps	109 cps

cpi = characters per inch

cps = characters per second

Setup Mode

Entering Setup Mode

1. Open the operator panel cover to access layer two.
2. Press **Setup** to put the printer in setup mode and print the Main Menu.
3. Press **LineFeed** to print a list of all the available options.
4. Select any option from the Main Menu by pressing the corresponding button. A new menu prints each time you press a button, displaying new selections.
5. After making your selection, the printer prints a page with the changes shown.

Exiting Setup Mode

1. Press **Set TOF** until the printer returns to the Main Menu, or press **Pitch** from any menu containing a **Return to Main Menu** selection.
2. Press **Set TOF** again to exit Setup mode. New settings are saved only when the printer exits Setup mode.

Note: If the printer runs out of paper while using Setup mode, load more paper into the tractor pins and press **Setup** to continue.

Setup Menu Options

Menus	Function
Forms Macro options	Customize macros to print a variety of forms.
Data options	Defines how information is processed.
Control options	Defines how the printer performs basic tasks.
Emulation options	Determines how the printer interacts with software applications.
Interface options	Defines how information is transferred from computer to the printer.

Interface Menu Options

Menus	Function
Interface	<ul style="list-style-type: none"> • Automatically select the printer interface. • Use the parallel cable. • Use the USB cable. • Use the serial cable (only appears if optional serial adapter is installed).
Honor Init	<ul style="list-style-type: none"> • Enable honors the init signal on the parallel port. • Disable ignores the init signal on the parallel port.
Data speed	<ul style="list-style-type: none"> • 300 bps • 600 bps • 1200 bps • 2400 bps • 4800 bps • 9600 bps • 19200 bps
Data bits	7, 8
Parity	No, Ignore, Odd, Even
Stop bits	1, 2
Protocol	<ul style="list-style-type: none"> • XON/XOFF • MultiXON/XOFF • DTR Pacing

Printer Settings

Setting The Tear Off Position

When Auto Tear Off is on, or set to One Second, it moves the top perforation of a continuous form to the tear off position, when all of the following are true:

- The printer has finished printing.
- The paper has advanced to the Top-Of-Form on the next page.
- No data, printer control codes, or escape codes have been sent to the printer after advancing to the Top-Of-Form.
- The print buffer has not received data for one second.

If you have already set Top-Of-Form and now want to change the tear off bar position, follow these steps:

1. Press **Start/Stop** to take the printer offline.
2. Press and hold **Tear Off** until the printer beeps.
3. Open the operator panel cover to access layer two.
4. Press **Micro** ↑ or **Micro** ↓ to move the paper to the correct position on the tear off bar.
5. Close the operator panel cover. The printer beeps twice. The paper rolls backward, then goes to the new tear off position. The Ready light is on.

The paper remains at the current Tear Off position until you send another job to the printer. The paper moves from the tear off position to the Top-Of-Form and begins printing.

Setting Top-Of-Form (Continuous - Pull Mode)

1. Turn the printer on. The Paper Out light blinks if no paper is loaded.
2. Move the paper select lever down to the continuous forms position.
3. Load continuous form paper on the pull tractor feed pins.
4. Open the operator panel cover to access layer two.
5. Press any paper movement button (**LineFeed**, **Micro**↑ or **Micro**↓) to move the paper to the Top-Of-Form position.
6. Use the second sheet of continuous forms to set Top-Of-Form.
7. Press **Set TOF** to set and save Top-Of-Form.
8. Close the operator panel cover. Top-Of-Form is not saved if the printer is turned off, or runs out of paper when the printer is in pull tractor mode.
9. Press **Start/Stop** to set the printer online.

Setting Top-Of-Form (Cut Forms - Envelopes)

Top-Of-Form can range from minus 1 to plus 22 inches from the top of cut sheet paper. To set and save Top-Of-Form:

1. Turn the printer on. The Paper Out light blinks if no paper is loaded. If the Paper Out light is off, tear off excess forms and press **Load/Unload**. If an individual form is loaded, press **FormFeed** to clear the paper path.
2. Move the paper select lever up to the cut forms position.
3. Load a cut sheet of paper or envelope through the manual feed door. The printer moves the paper or envelope to the current Top-Of-Form, if Auto Cut Sheet is set to on. If not, press **FormFeed** when the Paper Out light goes off.
4. Open the operator panel cover to access layer two.
5. Press any paper movement button (**LineFeed**, **Micro**↑, or **Micro**↓) to align with the horizontal lines (located on the platen) with the Top-Of-Form you want.
6. Press **Set TOF** to set and save Top-Of-Form.
7. Close the operator panel cover.
8. Press **Start/Stop** to set the printer online.

Options

The 24xx printers support the following options:

- Auto Sheet Feeder (ASF)
- Internal serial interface (RS232)
- OKI emulation (9 wire only)
- Tractor 2 Sheet Feeder

Tools

The basic tools necessary to service the 24xx-100 printers are:

- Basic CE tool kit
- #1 Phillips screwdriver
- #2 Phillips screwdriver
- Feeler gauges 0.33 mm (0.013 in.) 0.37 mm (0.015 in.)
- Analog or digital volt-ohmmeter

Abbreviations

CSU	Customer Setup
EPROM	Erasable Programmable Read-Only Memory
ESD	Electrostatic Discharge
FRU	Field Replaceable Unit
HV	High Voltage
LAN	Local Area Network
LED	Light-Emitting Diode
LV	Low Voltage
POR	Power-On Reset
POST	Power-On Self Test
V ac	Volts alternating current
V dc	Volts direct current

2. Diagnostic Information

Start

Make a quick visual check for defects (loose or broken parts, unplugged connectors, paper jams, and so on).

Voltage, Ground, And Continuity Readings

Voltage Readings

All DC voltages must be within +5% through -10% of the values to be considered correct. Unless stated otherwise, all connectors should be connected normally when a voltage measurement is performed.

When a “Line Voltage” measurement is to be performed, the voltage on United States and Canada printers should be between 100 V ac and 127 V ac. On World Trade printers, the voltage is according to each country’s specification.

Ground Checks

To check for a correct ground, measure the voltage between the ground and a known good voltage source. The voltage measurement must be the same as the source voltage to consider that the ground is correct. Continuity measurements may be used to check grounds, however, be sure to measure to a known good ground using the lowest ohms scale and check for zero ohms.

CAUTION: Always unplug the power cord before doing any continuity measurement.

Continuity Readings

When measuring continuity, be sure no back circuits affect the measurement. If necessary, unplug connectors to remove any back circuits. Zero the ohm range on the lowest scale (X1). An open circuit will read infinity. A circuit with correct continuity will read zero ohms.

Error Indication Table

The following table describes the service check entries for the printer error indication codes.

When an error indication changes after you have entered a service check, you have an intermittent problem. If this occurs, leave the service check and go to **“Symptom Check Table” on page 2-5.**

LED	Status	Alarm	Action
Power Ready Tractor 2 Paper Out Panel Lock Font Lock	ON ON ON ON ON ON	None	POST RAM, ROM Controller Error Go to “POST Service Check” on page 2-26.
Power Ready Paper Out Panel Lock	ON Blinking Blinking Blinking	None	Switch Scan Test Error Go to “Operator Panel Service Check” on page 2-21.
Power Ready Paper Out Font Lock	ON Blinking Blinking Blinking	None	NVRAM Read/Write Error Turn the printer off and then back on. If you get the same error during power-up, replace the logic board and readjust the bidirectional print adjustment. Go to “Bidirectional Print Adjustment” on page 4-4. If the printer completes POST successfully and eventually gets the same error, go to “Intermittent Problem Service Check” on page 2-18.

LED	Status	Alarm	Action
Power Ready Paper Out Panel Lock Font Lock	ON Blinking Blinking Blinking Blinking	Beeps 10 times	Home Position Error Go to “Carrier Service Check” on page 2-16. Tractor 2 Home Position Error If Tractor 2 is installed, remove it to determine whether the problem is with the carrier home position sensor or the Tractor 2 home position sensor. See the “Tractor 2 Service Check” on page 2-33.
		None	Home Position Error Without Alarm Go to “Power Service Check” on page 2-27.
Power Ready Tractor 2 Paper Out Font Lock	ON Blinking Blinking Blinking Blinking	None	Timer Error Turn the printer off and then back on. If you get the same error during power-up, replace the logic board and readjust the bidirectional print adjustment. Go to “Bidirectional Print Adjustment” on page 4-4.
Power Ready Tractor 2 Paper Out Font Lock	ON Blinking Blinking Blinking Blinking	None	Hardware Drive Error The printhead or the printhead cable(s) can cause this error. Go to “Printhead Service Check” on page 2-29. Turn the printer off and then back on. If you get the same error, replace the logic board and readjust the “Bidirectional Print Adjustment” on page 4-4. If the printer completes POST successfully and eventually gets the same error, go to “Intermittent Problem Service Check” on page 2-18.

LED	Status	Alarm	Action
All LEDs	OFF	None	Power Failure Check the continuity of the power cord and the voltage of the user's outlet. If they are correct, go to “Power Service Check” on page 2-27.
Power Tractor 2 Paper Out Panel Lock Font Lock	ON OFF OFF OFF OFF	None	Operator Panel Failure Go to “Operator Panel Service Check” on page 2-21.
Any LED on and Power LED off		None	Go to “Operator Panel Service Check” on page 2-21.
If the Power LED blinks or changes intensity.		None	Go to “Power Service Check” on page 2-27.

Symptom Check Table

1. Select the symptom that best describes the problem.
2. Perform the appropriate action before you go to the indicated service check.

Abnormal Indications

Symptom	Action
<p>7 or more lights turn on but do not turn off.</p> <p>The Power light is on, but POST will not run.</p>	<p>Disconnect the interface cable from the printer and turn the printer off and then on. If POST now runs correctly, the problem is in the computer or interface cable.</p> <p>Go to “POST Service Check” on page 2-26.</p>

Abnormal Noise Problems

Symptom	Action
<p>During POST, abnormal noise comes from the carrier.</p>	<p>Check the ribbon cartridge for binds or damage.</p> <p>Go to “Carrier Service Check” on page 2-16.</p>
<p>During idling, abnormal noise comes from the printer.</p> <p>When feeding paper, abnormal noise is created.</p> <p>During printing or POST, abnormal noise is created.</p>	<p>Go to “Abnormal Noise Service Check” on page 2-13.</p>

Abnormal Print Operation Problems

Symptom	Action
Printer will not print, or become ready. Abnormal operation, incorrect characters, or incorrect line width. Printer is ready but will not print from the computer correctly. Undefined or incorrect character(s).	Be sure the interface cable is connected properly. Go to “No Print or Abnormal Print Service Check” on page 2-21.
Slow printing speed.	Go to “Print Speed Service Check” on page 2-28.

Auto Sheet Feeder Problems

Symptom	Action
Auto sheet feeder will not feed paper. Auto sheet feeder double feeds. Auto sheet feeder has intermittent feed problems.	Be sure Sheet Feed is enabled in the Setup Mode. Be sure the paper select lever is in the cut sheet position. Go to “Auto Sheet Feeder (ASF) Service Check” on page 2-14.

Error Indications

Symptom	Action
Ready and Paper Out lights blink.	Turn the printer off and then on. Go to “Abnormal Indications” on page 2-5.
Paper Out and Font lights blink.	Turn the printer off and then on. Go to “Irrecoverable Operator Errors” on page 2-12.

Operator Panel Problems

Symptom	Action
Start/Stop does not function but no error is indicated. Only the Power light turns on. One or more buttons do not function. One or more lights do not function.	Turn the printer off and then on. Go to “Operator Panel Service Check” on page 2-21.

Paper Feed Problems

Symptom	Action
Paper Out is blinking with paper in the printer.	Go to “Paper Present Sensor Service Check” on page 2-22.
Paper Out does not blink when no paper is in the printer and ASF is not installed. Print operation starts without paper.	Be sure the paper present sensor is not blocked. Go to “Paper Present Sensor Service Check” on page 2-22.

Symptom	Action
<p>Load/Unload does not function when the push tractor is installed.</p> <p>Form feed length is not correct.</p> <p>Load/Unload functions with cut sheets in use.</p>	<p>Be sure the paper select lever is in the correct position.</p> <p>Go to “Paper Select Sensor Service Check” on page 2-25.</p>
<p>Continuous forms feed, but cut sheets fail to load.</p>	<p>Be sure the paper select lever is in the cut sheet position.</p> <p>Verify that continuous forms have been parked using the Load/Unload button.</p> <p>Be sure Auto Cut Sheet is enabled in the Setup Mode.</p> <p>Go to “Paper Select Sensor Service Check” on page 2-25.</p>
<p>Load/Unload functions when the pull tractor is installed.</p> <p>With Paper Out blinking, FormFeed does not operate until paper is located at first print line.</p>	<p>Be sure the paper select lever is in the tractor position.</p> <p>Go to “Pull Tractor Sensor Service Check” on page 2-31.</p>

Symptom	Action
<p>Lower feed roll shaft rotates, but paper does not feed.</p> <p>Pressing FormFeed does not feed paper.</p> <p>Abnormal noise created while feeding.</p> <p>Paper jams, skews or creases.</p> <p>Incorrect or no line spacing: wider, narrower, or overlapping lines.</p> <p>Push/Pull Tractor does not work.</p>	<p>Be sure the paper select lever is in the correct position.</p> <p>Go to “Paper Feed Service Check” on page 2-23.</p>
<p>Incorrect Top of Form positioning.</p>	<p>Go to “Top-Of-Forms Service Check” on page 2-32.</p>

Power Problems

Symptom	Action
<p>When the power switch is on, the Power light does not turn on or the printer does not start.</p> <p>The Power light blinks or changes intensity.</p>	<p>Check continuity of the power cord and the voltage of the user's outlet.</p> <p>Go to “Power Service Check” on page 2-27.</p>

Print Quality Problems

Symptom	Action
<p>No print, but carrier moves as if printing.</p>	<p>Adjust the form thickness lever to a lower number.</p> <p>Be sure the printhead cables are not loose or damaged.</p> <p>Be sure the interface cable is connected properly.</p> <p>Check the ribbon cartridge for binds or damage.</p> <p>Go to “Print Speed Service Check” on page 2-28.</p>
<p>Print density is light.</p>	<p>Turn the ribbon advance knob on the print cartridge from 1 to 2 to increase the darkness of print.</p> <p>If the ribbon has reached its end of life or is worn, replace the ribbon cartridge.</p> <p>Go to “Carrier Service Check” on page 2-16.</p>
<p>Uneven print density across the print line.</p> <p>Specific dots missing.</p> <p>Extra dots or lines printing.</p>	<p>Turn the ribbon advance knob on the print cartridge from 1 to 2 to increase the darkness of print.</p> <p>Be sure the printhead cables are connected correctly to the printhead.</p> <p>Clean the printhead.</p> <p>Set the form thickness lever to position “1” and run the print test.</p> <p>Go to “Carrier Service Check” on page 2-16.</p>
<p>Scattered ink smearing, blurred characters.</p> <p>Fuzzy print.</p>	<p>Clean the printhead nose.</p> <p>Clean the ribbon guide and shield.</p> <p>If the ribbon has reached its end of life or is worn, replace the ribbon cartridge.</p> <p>Go to “Carrier Service Check” on page 2-16.</p>
<p>Wavy vertical lines, uneven left margin or character width is reduced.</p>	<p>Clean and lubricate the carrier shaft.</p> <p>If the carrier drive belt is worn or broken, replace the carrier unit.</p> <p>Go to “Carrier Service Check” on page 2-16.</p>

Ribbon Feed Problems

Symptom	Action
Ribbon comes off, becomes loose or folded, or jams. Ribbon feeds correctly but is noisy.	Check the ribbon cartridge for binds or damage. Go to “Carrier Service Check” on page 2-16.

Irrecoverable Operator Errors

Paper Out and **Font** lights blink. If this indication occurs, the problem may be with the paper present sensor or the paper select sensor. Check the following in the order listed and if the printer does not work correctly, go to the indicated service check.

Paper Present Sensor

Action	Check
Remove all paper from the printer. Turn the power on.	Paper Out blinks when paper does not exist. Paper Out turns off when paper exists. Go to “Paper Present Sensor Service Check” on page 2-22.

Paper Select Sensor

Action	Check
Turn the power off. Install the Push Tractor. Set the paper select lever to the tractor position and load continuous forms. Turn the power on.	Load/Unload function correctly. Go to “Paper Select Sensor Service Check” on page 2-25.
Remove the continuous forms. Set the paper select lever to the cut sheet position and insert a cut sheet.	When Auto Ready Cut Sheet is enabled, paper feeds automatically. When Auto Ready Cut Sheet is disabled, press FormFeed to load a cut sheet. Verify Load/Unload does not function. Go to “Paper Select Sensor Service Check” on page 2-25.

Service Checks

Abnormal Noise Service Check

Check the entire printer for loose parts.

	FRU	Action
1	Ribbon Cartridge	Remove and reinstall the ribbon cartridge.
2	Printhead	<p>Disconnect the printhead cable(s).</p> <p>Run the print test (do not fold or damage the cables during the test). Go to “Print Test” on page 3-3.</p> <p>Replace the printhead, if the noise is gone.</p>
3	Carrier Motor Ribbon Drive Mechanism	<p>Disconnect the carrier motor connector CN2 from the logic board. Turn the printer off and then on.</p> <p>If the abnormal noise is gone, look for a problem with the carrier motor or ribbon drive mechanism. Go to “Carrier Service Check” on page 2-16.</p>
4	Paper Feed Mechanism	<p>Disconnect the paper feed motor CN1 from the logic board.</p> <p>Perform the Print Test. Go to “Print Test” on page 3-3.</p> <p>If the abnormal noise is gone, look for the problem in the paper feed mechanism.</p>

Auto Sheet Feeder (ASF) Service Check

Note: Be sure the sheet feeder is enabled in the Setup Mode. Go to **“Setup Mode” on page 1-2.**

Auto Sheet Feeder Principles of Operation

The Auto Sheet Feeder (ASF) feeds into the cut sheet paper entry throat. To use the ASF:

- The paper select lever must be set to cut sheet.
- The Auto Sheet Feeder must be selected in the Setup menu.

Continuous forms can be used with the ASF installed by moving the paper select lever to continuous forms and pressing **Start/Stop** to feed the continuous forms to the first print line.

The ASF contains no electrical parts. It is driven from the gear on the inside right side frame of the printer.

The combination lock mechanism is a clutch that causes the ASF pick rollers to feed only one sheet of paper at a time. When **Auto Sheet Feeder** is selected on the Setup Menu, the cut sheet paper drive reverses itself for a short distance during paper loading. This reversal engages the clutch and thus engages the paper picker rollers, which feed the top sheet from the cut sheet paper stack. The sheet is fed about 5 inches (125 mm) and the paper path briefly reverses again; this disengages the clutch and the picker rollers. The sheet is then fed to the print line by the upper and lower feed rollers of the ASF and the lower feed rollers of the printer. Although the ASF picker rollers continue to turn as the paper is fed, their drive is disengaged and they are actually turned by the paper.

	FRU	Action
1	Paper Select Sensor	<p>With the paper select lever in the cut sheet position, do the following:</p> <ul style="list-style-type: none"> • Try to load a cut sheet with Load/Unload. (This button should not work) • If paper loads, go to “Paper Select Sensor Service Check” on page 2-25.
2	Paper Feed	<p>If the paper does not feed, do the following:</p> <ul style="list-style-type: none"> • Remove the ASF. • Be sure the base printer feeds paper correctly. • If the base printer does not feed paper correctly, go to “Paper Feed Service Check” on page 2-23.
3	Gear Train	<p>Be sure the ASF drive gear on the inside right side frame of the printer rotates.</p> <p>Inspect the right side gear train for damage or debris.</p> <p>Remove the ASF right cover and ensure that all the gears are in good condition.</p>
4	Combination Lock Mechanism	<p>Install the ASF and press FormFeed.</p> <p>If the picker drive shaft does not rotate, replace the combination lock mechanism.</p>
5	Left and Right Hoppers	<p>If the ASF picker rollers rotate but a single sheet is not picked, inspect the springs and corner separators on the left and right hoppers.</p> <p>Be sure the paper load lever is in the correct position.</p>

Carrier Service Check

Note: The Carrier Service Check includes the carrier drive, home position sensor and ribbon feed.

	FRU	Action
1	Carrier	<p>Verify the carrier motor connector is connected to the logic board at CN2. If the carrier motor connector is connected properly, check the carrier belt and the ribbon cartridge for wear or damage. Check the belt and pulley engagement.</p> <p>Manually move the carrier the full length of the carriage to check for binds and to be sure the ribbon advances when the carriage moves in either direction.</p> <p>If the carrier binds check the following:</p> <ul style="list-style-type: none"> • Correct printhead-to-platen gap. Go to “Printhead-to-Platen Gap Adjustment” on page 4-2. • Clean and lubricated carrier shaft. • Idler pulley not binding. • Ribbon drive rack gear teeth not damaged. <p>If the carrier still binds: Remove the belt and move the carrier again.</p> <ul style="list-style-type: none"> • If the bind is gone, replace the carrier motor. <p>If the bind remains, replace the carrier.</p> <p>After replacing the logic board or any parts affecting the carrier, perform the bidirectional print adjustment. See “Bidirectional Print Adjustment” on page 4-4.</p>
2	Home Position Sensor	<p>If the carrier moves manually without binding, but the home position error still occurs, verify that the logic board is receiving +40 V dc on pin CN12-1. Check that the 5 V dc home position sensor signal is reaching the logic board.</p> <p>Replace the sensor, or the short flexible cable as necessary.</p>

	FRU	Action
3	Carrier Motor	<p>If the home position sensor is okay, verify the the resistance of the carrier motor windings are approximately 2 ohms for all printers.</p> <p>Check the resistance at the following pin locations:</p> <p style="text-align: center;">CN2 - 1 and CN2 - 3 CN2 - 2 and CN2 -4</p>
4	Logic Board	<p>If all parts appear okay but the home position error still occurs, replace the logic board.</p> <p>After replacing the logic board or any parts affecting the carrier, perform the bidirectional print adjustment. See “Bidirectional Print Adjustment” on page 4-4.</p>

Intermittent Problem Service Check

	FRU/Symptom	Action
1	The printer sometimes fails before POST is complete.	<p>Check for the following:</p> <ol style="list-style-type: none"> 1. Loose connectors. Reconnect all connectors to the logic board. 2. Electrical noise or static discharge. <p>Check the following:</p> <ul style="list-style-type: none"> • Power supply ground. • Printer frame ground. • Printer interface cable is grounded and shielded. 3. Intermittently low voltages. Check for ac and all dc voltages and short circuits on the logic board. <ol style="list-style-type: none"> a. Check the user's outlet voltage and ensure that it is within tolerance. b. Check the continuity of the power cord. c. Disconnect the power supply cable from connector CN12 on the logic board. Turn the printer power on and check all dc output voltages at CN12-1, CN12-2, and CN12-6. <p>Verify the following output voltages:</p> <ul style="list-style-type: none"> CN12 - 1 (+40 V dc \pm10%) CN12 - 2 (+40 V dc \pm10%) CN12 - 3 (GND) CN12 - 4 (GND) CN12 - 5 (Signal GND) CN12 - 6 (+5 V dc \pm5%) CN12 - 7 (Power Save Mode) <ul style="list-style-type: none"> • If the voltages are incorrect, replace the power supply. • If the failure remains, replace the logic board. <p>Note: When replacing the logic board, always reset the bidirectional print adjustment. See "Bidirectional Print Adjustment" on page 4-4.</p>

	FRU/Symptom	Action
2	Printer power sometimes turns off.	<p>The cause of this problem may be that the power circuit is failing, or the wiring is intermittently open. Check the following in sequence:</p> <ol style="list-style-type: none"> 1. Check the user's outlet voltage and be sure it is within tolerance. 2. Check the continuity of the power cord. 3. Disconnect the power supply cable from connector CN12 on the logic board. Turn the printer power on and check all dc output voltages at CN12-1, CN12-2 and CN12-6. <p>Verify the following output voltages:</p> <ul style="list-style-type: none"> CN12 - 1 (+40 V dc \pm10%) CN12 - 2 (+40 V dc \pm10%) CN12 - 3 (GND) CN12 - 4 (GND) CN12 - 5 (Signal GND) CN12 - 6 (+5 V dc \pm5%) <ul style="list-style-type: none"> • If one of the voltages is 0, go to “Power Service Check” on page 2-27. • If the voltages are not 0 but are incorrect, replace the power supply unit.
3	Intermittently poor print quality.	<ul style="list-style-type: none"> • Remove paper jams from the paper path. • Clean all feed roller surfaces. • Clean the ribbon shield and printhead. • Clean the platen surface. • Install the ribbon cartridge correctly. If the ribbon has reached end of life, have the user replace the ribbon cartridge.

	FRU/Symptom	Action
4	If the prior suggestions have not corrected the problem.	<p>The following may cause undefined or intermittent failures:</p> <ol style="list-style-type: none"> Loose connector pins that fail to contact. Check the following: <ul style="list-style-type: none"> Reconnect the connectors of all FRUs and printer interface cables. Check the continuity of the line cord. Electrical noise. Check the following: <ul style="list-style-type: none"> Power supply ground. Printer frame ground. Printer interface cable is grounded or shielded. Undefined data in user applications. Check the baud rate at the controller. Check that the printer interface cable matches the printer.
5	Problem occurs only in specific user applications.	<p>Perform the Hex Trace Print (hexadecimal printing) by the following procedure and check the data streams. Go to “Hex Trace Mode” on page 3-4.</p> <ol style="list-style-type: none"> Turn the printer off. Press and hold Tractor and turn the printer on. Have the user print the failing job. To stop printing, turn the power off. <p>If the failure still occurs, replace the logic board. Be sure to reset the bidirectional print adjustment. See “Bidirectional Print Adjustment” on page 4-4.</p>

No Print or Abnormal Print Service Check

	FRU/Function	Action
1	Logic Board	If the print test does not complete correctly, replace the logic board and reset the bidirectional print adjustment. See “Bidirectional Print Adjustment” on page 4-4.
2	Interface Cable	Check the connection and continuity of the interface cable.
3	Emulation Mode	Enter the Setup Menu and be sure the printer is in the correct emulation mode for the computer, either IBM or Epson. Go to “Setup Mode” on page 1-2.

Operator Panel Service Check

If the operator panel is locked, only the **Start/Stop, FormFeed, Tear Off** and **Load/UnLoad** buttons are active. 24xx printers have a Padlock LED to indicate that the operator panel is locked. To lock or unlock the operator panel, turn the printer off and while holding the **Load/Unload** and **Tractor** buttons, turn the printer on.

	FRU	Action
1	Operator Panel Cable	<p>Disconnect the operator panel cable from the operator panel and the logic board, and verify continuity of the operator panel cable.</p> <p>Connect the operator panel to the logic board and be sure +5 V dc is present at connectors CN13-1 and CN13-3.</p> <p>Replace the operator panel cable, or the power cable, as necessary.</p>
2	Operator Panel	If the problem remains, replace the operator panel.

Paper Present Sensor Service Check

	FRU	Action
1	Paper Present Sensor	<p>With no paper in the printer, the tractor in the push position, and the paper select lever set to continuous forms, press Load/Unload; the gear train should turn forward to load paper.</p> <p>Activate the paper present sensor with a screwdriver and press Load/Unload again; the gear train should turn backward to park paper.</p> <p>Measure the voltage between CN5-2 (paper present signal) and CN5-3 (GND) on the logic board. There should be 0 V dc when there is paper in the printer, and +5 V dc when there is no paper in the printer.</p> <ul style="list-style-type: none"> • Be sure the paper present sensor and its actuator are properly installed and not damaged. • If the problem remains, replace the paper present sensor.
2	Logic Board	<p>If the ASF is being used, it is normal for the paper out LED not to blink when there is no paper in the printer. Do the following:</p> <ul style="list-style-type: none"> • Enter the Setup Menu. • Be sure the ASF setting is off unless the ASF is installed. • If the paper present sensor is good and the ASF setting is on, replace the logic board and reset the “Bidirectional Print Adjustment” on page 4-4.

Paper Feed Service Check

Note: If paper creases or jams frequently, verify the paper is neither too thick nor thin. If necessary, refer the user to the User's Guide for specifications of acceptable papers.

If the paper does not stop in the correct location, see **“Paper Present Sensor Service Check” on page 2-22** and the **“Top-Of-Forms Service Check” on page 2-32**.

	FRU / Symptom	Action
1	Auto Sheet Feeder	<p>If the Auto Sheet Feeder is installed, remove it. Enter the Setup Menu and reset ASF to off. Verify that the printer works correctly without the ASF installed.</p> <p>If the printer fails only with the Auto Sheet Feeder installed, go to “Auto Sheet Feeder (ASF) Service Check” on page 2-14.</p>
2	Gear Train	<p>Remove all paper from the printer.</p> <p>Press FormFeed several times and examine all rotating parts to find the problem.</p> <p>The feed rollers and pinch roller should all be clean and in good condition and should all rotate when pressing FormFeed.</p>
3	Paper Selector Lever	<p>Be sure the selector lever alternately engages and disengages the tractor gear and the ASF drive gear.</p> <p>Check the operation of the following parts as you move the paper select lever:</p> <ul style="list-style-type: none">• The tractor gear engages correctly in the continuous forms position.• The tractor belts are in good condition and rotate correctly.• The pinch roller shafts move downward as the lever moves to the cut sheet position.• The paper separator moves upward as the lever moves to the cut sheet position.

	FRU / Symptom	Action
4	Operator Panel	<p>If paper does not move at all, verify the Load/Unload button is working as follows:</p> <p>With the tractor in the push position, power off, power on and then press Load/Unload. The carrier should move to the center of the platen. If it does not, go to “Operator Panel Service Check” on page 2-21.</p>
5	Paper Feed Motor	<p>Disconnect the paper feed motor cable CN1 from the logic board. No pin should have continuity to ground. The resistance should be between 8 to 9 ohms, between CN10 - 1 and CN10 - 5, CN10 - 2 and CN10 - 5, CN10 - 3 and CN10 - 5, CN10 - 4 and CN10 - 5.</p>
6	Paper Select Sensor	<p>Remove all paper from the printer and place the tractor in the push position.</p> <p>Press FormFeed and time how long the gear train rotates.</p> <ul style="list-style-type: none"> • With the paper select lever in the cut sheet position (sensor open) the gear train should rotate for less than 2 seconds. • With the lever in the continuous forms position (sensor closed), the gear train should rotate for more than 3 seconds. <p>If the printer does not do either of the above:</p> <ul style="list-style-type: none"> • Inspect the sensor to be sure it opens and closes by the paper separator. • Replace the sensor if the resistance does not change from zero to infinite as the paper select lever is moved.
7	Pull Tractor Sensor	<p>If the pull tractor sensor fails to close, Load/Unload and Auto Tear Off do not work when using push tractors.</p> <p>If the sensor fails to open, Load/Unload tries to park paper when using pull tractors, but the paper feeds all the way out of the tractors and cannot reload. See “Pull Tractor Sensor Service Check” on page 2-31.</p>
8	Logic Board	<p>If no other problem is found, replace the logic board and reset the “Bidirectional Print Adjustment” on page 4-4.</p>

Paper Select Sensor Service Check

If form feed length is off by about 1 inch (25 mm), enter Setup Mode and verify that the form length setting is correct. Go to **“Setup Mode” on page 1-2.**

	FRU	Action
1	Paper Select Sensor	<p>Remove all paper from the printer and do the following:</p> <ul style="list-style-type: none"> Place the tractor in the push position and be sure the Auto Sheet Feed (ASF) is set to OFF in Setup Mode. Press FormFeed and time how long the gear train rotates. <p>With the paper select lever in the cut sheet position (sensor open) the gear train should rotate for less than 2 seconds. With the lever in the continuous forms position (sensor closed), the gear train should rotate for more than 3 seconds. If the gear train does not rotate for more than 3 seconds:</p> <ul style="list-style-type: none"> Inspect the sensor to be sure it opens and closes by the paper separator. Replace the paper select sensor if the resistance does not change from zero to infinite, as the paper select lever is moved from cut sheet to continuous forms. <p>If the paper select sensor is good, but the gear train does not run the right length of time:</p> <ul style="list-style-type: none"> Set the head gap to position 1 and disconnect the short flexible cable from CN8 on the logic board. Check the continuity between CN8-2 (paper select sensor) and GND while actuating the paper select lever. <p>If the resistance is incorrect, replace the logic board and reset the “Bidirectional Print Adjustment” on page 4-4.</p>

	FRU	Action
2	Pull Tractor Sensor	<p>A failed pull tractor sensor can cause Load/Unload to malfunction.</p> <p>With the tractor in the push position:</p> <ul style="list-style-type: none"> • Press Load/Unload several times while alternately holding down and releasing the left pull tractor actuator. The paper should not park or load when the pull tractor actuator is held down. • If the paper does park or load with the pull tractor actuator held down, go to “Pull Tractor Sensor Service Check” on page 2-31.

POST Service Check

	FRU	Action
1	Cables	<p>A faulty interface cable can cause a POST error. Disconnect the interface cable from the printer and turn the printer off and then on.</p> <p>Check the connections of the power cable to the logic board.</p> <p>Check the condition and continuity of the operator panel cable.</p>
2	Code Module	Turn the printer off and then on. If you get the same error during power-up, verify the code module on the logic board is correctly installed.
3	Logic Board	Replace the logic board if necessary and reset “Bidirectional Print Adjustment” on page 4-4.

Power Service Check

	FRU	Action
1	Power Supply	<p>If the carrier does not move to the left after turning the printer off and then on, be sure the line cord voltage to the power supply is correct and the power supply outputs are +40 V dc at CN12-1, +40 V dc at CN12-2 and +5 V dc at CN12-6.</p> <p>If the voltages are incorrect:</p> <ul style="list-style-type: none"> • Check the internal fuse before replacing the power supply. Generally if F1 is blown, it is due to a short in the printhead; replace the printhead and the fuse before powering on again. • Be sure the power supply cable from the power supply to the logic board is not damaged and correctly installed.
2	Operator Panel Operator Panel Cable	If there is still a power LED problem, check the operator panel cable continuity and replace the cable or the operator panel.
3	Carrier Motor	Disconnect the carrier motor from logic board CN2 and turn the printer off and then on. If the power LED lights correctly only with the carrier motor disconnected, replace the carrier motor.
4	Paper Feed Motor	Disconnect the paper feed motor from logic board CN1 and turn the printer off and then on. If the power LED lights correctly only with the paper feed motor disconnected, replace the paper feed motor.
5	Printhead Printhead Cables	<p>Disconnect the printhead cable from the logic board and turn the printer on. If the power LED lights correctly only with the printhead cables disconnected from the logic board, there is a short in the printhead or printhead cables.</p> <p>Disconnect the printhead cable from the logic board and be sure none of the leads on the cable are shorted to ground.</p>

	FRU	Action
6	Logic Board	If no problem is found with the other components, but the power problem still remains, replace the logic board and reset “Bidirectional Print Adjustment” on page 4-4.

Print Speed Service Check

The speed of the 24xx printers varies with the font, forms thickness setting and printhead temperature. Graphics output may print slowly due to data throughput limitations. Thermal sensing is built into the printhead on 249x printers and protects the printhead from overheating.

	FRU	Action
1	Head Gap Sensor	<p>Check the function of the head gap sensor by turning the printer on with the Macro button pressed. Open the operator panel to the second level and do the following:</p> <ul style="list-style-type: none"> • With the forms thickness lever at 1, Macro LED 1 lights. • With the forms thickness lever at 2 and 3, Macro LED 2 lights. • With the forms thickness lever at 4 through 7, Macro LED 3 lights. <p>Disconnect the head gap sensor from connector CN4 on the logic board. Place the forms thickness lever in position 1 and verify continuity at the following pin locations:</p> <p style="text-align: center;">CN4 - 1 and CN4 - 2 CN4 - 2 and CN4 - 3</p> <p>Place the forms thickness lever in positions 2 and 3 and verify continuity at the following pin location:</p> <p style="text-align: center;">CN4 - 1 and CN4 - 2</p> <p>Verify no continuity at forms thickness lever positions 4 through 7.</p>

Printhead Service Check

	FRU	Action
1	Printhead Cables Printhead	<p>If the printout contains missing or extra dots or lines, do the following:</p> <ul style="list-style-type: none"> • Check the continuity and connection of the printhead cables and the short flexible cable. • Be sure the voltages to the logic board are correct. <p>If dots are missing:</p> <ul style="list-style-type: none"> • Perform the print test to determine which wire is not firing. • Remove the printhead and verify that no pins on the printhead are broken or missing. If pin(s) are missing, replace the printhead. • Check the printhead resistance according to “Printhead Impedance Tables” on page 2-30. Be sure no pins have continuity to the printhead housing. <p>If the printout does not contain missing or extra dots or lines, be sure the printhead is securely installed in the carrier and perform the “Printhead-to-Platen Gap Adjustment” on page 4-2.</p>
2	Carrier Shaft Carrier Unit Platen Assembly Printhead Nose Ribbon Guide	Check and replace worn or damaged parts.

Printhead Impedance Tables

2480, 2490 - Approximately 5 ohms

Dot	Connector
1	CN400-13 & CN400-4
2	CN400-9 & CN400-6
3	CN400-15 & CN400-18
4	CN400-1 & CN400-7
5	CN400-17 & CN400-20
6	CN400-5 & CN400-2
7	CN400-19 & CN400-16
8	CN400-8 & CN400-3
9	CN400-10 & CN400- 14

2481, 2491 - Approximately 8 to 16 ohms

Dot	Connector	Dot	Connector
1	CN300-1 & CN301-9	13	CN300-1 & CN300-9
2	CN300-1 & CN301-11	14	CN300-1 & CN300-11
3	CN300-1 & CN301-7	15	CN300-1 & CN300-2
4	CN300-1 & CN301-13	16	CN300-1 & CN300-16
5	CN300-1 & CN301-5	17	CN300-1 & CN301-4
6	CN300-1 & CN301-15	18	CN300-1 & CN300-14
7	CN300-1 & CN301-3	19	CN300-1 & CN301-6
8	CN300-1 & CN301-17	20	CN300-1 & CN300-12
9	CN300-1 & CN301-1	21	CN300-1 & CN300-4
10	CN300-1 & CN301-18	22	CN300-1 & CN300-10
11	CN300-1 & CN301-2	23	CN300-1 & CN300-6
12	CN300-1 & CN301-16	24	CN300-1 & CN300-8

Pull Tractor Sensor Service Check

The pull tractor sensor detects the tractor in the pull position and disables load/unload and auto tear-off. A failed sensor may prevent load/unload from functioning, with the tractor in the push position.

	FRU	Action
1	Pull Tractor Sensor	<p>With the tractor in the push position, press Load/Unload several times while alternately holding down and releasing the left pull tractor actuator. The paper should load and unload when the actuator is not held down, and should not load or unload when the pull tractor actuator is held down.</p> <p>If the paper does not move correctly, disconnect CN3 from the logic board. There should be continuity from CN3-1 and CN3-2 when the left pull tractor actuator is pressed, and infinite resistance when the actuator is not pressed. Replace the sensor if necessary.</p> <p>If the sensor is good but the paper still does not move correctly, replace the logic board and reset the “Bidirectional Print Adjustment” on page 4-4.</p>

Top-Of-Forms Service Check

	FRU	Action
1	Top-Of-Form Sensor	Check that the top-of-form sensor and its flag are properly installed and are not damaged.
2	Logic Board	<p>Remove the paper and set the paper select lever to the cut sheet position and turn the printer on.</p> <p>Measure the voltage between logic board connector CN6-2 (TOF signal) and CN6-1 (GND). You should receive the following voltage readings:</p> <ul style="list-style-type: none"> • When there is paper in the printer the voltage should be 0 V dc. • When there is no paper in the printer the voltage should be 5 V dc. <p>Replace the top of form sensor if the voltage is incorrect.</p> <p>Replace the logic board if the voltage is correct, and reset the “Bidirectional Print Adjustment” on page 4-4.</p>

Tractor 2 Service Check

The Tractor 2 in-place sensor opens during installation, when its actuator touches the printer cover.

The home sensor detects the position of the slider:

- When Tractor 2 is selected, the motor-driven Tractor 2 slider pushes the printer sub slider cam lever to engage the printer gear train which drives the Tractor 2 tractors.
- When the Tractor 2 is deselected, the motor retracts the slider, disengages the Tractor 2 gear drive, and reengages the printer tractors.

10 Beeps and Blinking Ready, Paper, Font and Pitch LEDs

Tractor 2 home sensor never made after turning the printer off and then on, or made at the wrong time.

(The same error indication is used for carrier home failure.)

	FRU	Action
1	Tractor 2 Home Sensor	Remove the Tractor 2 and turn the printer off and then on again to determine if the fault is in the printer or Tractor 2. If the gear teeth chatter just before the beeps, replace the home sensor.

	FRU	Action
2	Logic Board	<p>Remove Tractor 2 from the printer but leave the cable connected. Be sure the slider (the black plastic piece just above the right cover) moves after turning the printer off and then on.</p> <p>If the slider does not move after turning the printer off and then on:</p> <ul style="list-style-type: none"> • Be sure the slider and gear train are properly connected and move freely with the power off. • Be sure the Tractor 2 board is receiving: +40 V dc on CN1-1 and +5 V dc on CN1-5. <p>If not, check the cable connection and the voltages at logic board CN10-1. The upper right pin at CN10 is pin 1 (+40 V dc) and the pin just beneath it is pin 5 (+5 V dc).</p> <p>If these voltages are not present replace the logic board.</p>
3	Tractor 2 Motor Board /Cable Asm	<p>Check the resistances of the Tractor 2 motor windings at CN5 on the Tractor 2 board. There should be 101 ± 5 ohms between pins:</p> <p style="text-align: center;">CN5 -1 and CN5 - 4 CN5 -1 and CN5 - 6 CN5 -2 and CN5 - 3 CN5 -2 and CN5 - 5</p> <p>If the motor is good, replace the board / cable assembly.</p> <p>For information on the Tractor 2 cable connectors, see “Tractor 2 Cable Connectors” on page 5-26.</p>

3 Beeps and Tractor 2 LED blinks 3 times

Tractor 2 selected from operator panel but printer does not detect Tractor 2 or detects that the Tractor 2 mechanism is not installed.

	FRU	Action
1	Tractor 2 Board/Cable Asm.	<p>Check the Tractor 2 in-place sensor or the cable connection.</p> <p>The in-place sensor actuator extends through the Tractor 2 cover and rests on the printer cover when Tractor 2 is installed.</p> <p>Remove the Tractor 2 cover and be sure the in-place sensor opens when the Tractor 2 is installed. The voltage at Tractor 2 CN1-13 should be +5 V dc with the sensor open and 0 with it closed.</p> <p>Replace the Tractor 2 board/cable assembly if the sensor signal is wrong.</p> <p>For information on the Tractor 2 cable connectors, see “Tractor 2 Cable Connectors” on page 5-26.</p>
2	Logic Board	<p>Check the cable connection from Tractor 2 to the printer.</p> <p>If possible, try the Tractor 2 with another printer to determine if the problem is the Tractor 2 board/cable assembly or the printer logic board.</p>

Tractor 2 Paper Feed Problems

	FRU	Action
1	Tractor 2	<p>Be sure the gear on the printer that drives Tractor 2 turns freely when the lever is not pressed, but remains still when the lever is pressed.</p> <p>Remove the Tractor 2 unit from the printer and remove all paper. With the paper select lever in the continuous forms position, press FormFeed; the tractors should rotate. Press the sub slider cam lever below the ASF/Tractor 2 drive gear and press FormFeed again; the tractors should not rotate but the drive gear should.</p> <p>Check the condition of the pin feed belts. With the printer off and be sure the slider does not bind.</p> <p>Verify:</p> <ul style="list-style-type: none"> • When the slider is to the rear, the white gear drives the tractors. • When the slider is to the front, the gear and tractors are not connected.
2	Tractor 2 Cover	<p>Remove the Tractor 2 cover and reinstall the Tractor 2 unit in the printer (if necessary, remove the printer covers also). Note that the small idler gear just below the slider is held in place by the cover. With the cover removed it tends to move off the stud. Also note that when operating the Tractor 2 with the printer cover removed, the Tractor 2 in-place sensor must be held open.</p> <p>Turn the printer on and look for mechanical problems.</p> <p>For information on the Tractor 2 cable connectors, go to “Signal Connections” on page 5-2.</p>

3. Diagnostic Aids

The printer contains self tests to help find and solve problems. You do not need to connect the printer to a computer or terminal to run these tests.

Types of self tests are:

- Power-On Self Test (POST)
- Print Test
- Hex Trace Mode (a computer or terminal is necessary)

The following are special machine modes that run when the printer is turned off and then back on:

Turn Printer On While Pressing	Results
LineFeed	Prints print test with sample fonts.
Tractor	Sets printer in Hex Trace mode.
Load/Unload & Tractor	Disables/Enables Operator Panel Lockout Mode.
Tearoff & Tractor with the printhead at the left limit	Resets the printer to the World Trade defaults.
Tearoff & Load/Unload with the printhead at the left limit	Resets the printer to the U. S. defaults.

Power-On Self Test (POST)

The following tests are automatically performed when the printer is turned on.

- LEDs Test - Checks operation of LEDs on the operator panel. The LEDs turn on and off after the printer is turned on, then all LEDs turn on for a few seconds.
- RAM Test - Checks that the CPU can write/read the RAM.
- Font ROM/Microcode Sum Test - Checks that the ROM data is correct.
- Timer/Interrupt Controller Test - Checks that this function works.
- NVRAM Test - Checks that the NVRAM data is correct.
- Switch Scan Test - Checks the buttons on operator panel.
- Carrier Initialization - Carrier moves to the left to activate the home position sensor, then moves to the first print position.
- Feed Initialization - Form feed motor rotates forward and then backward.

If any errors occur during the POST tests, a combination of blinking LEDs indicates which test failed. See **“Start” on page 2-1**.

Print Test

The print test helps you test and troubleshoot the printer. To start the print test:

1. Paper must be at the print position; test does not print if paper is parked.
2. Press and hold **Line Feed** and turn the printer on.
3. Release **Line Feed** when the printing starts.
4. To interrupt the printer test:
 - a. Press **Start/Stop**. The test stops after a complete line of characters prints.
 - b. Press **Start/Stop** to continue the test sample.
5. To stop the printer test, turn the printer off.

If the print test fails, go to **“Start” on page 2-1**.

Note: The short horizontal lines at the top of the sample are a test of each printhead wire numbered in sequence, from top to bottom.

Hex Trace Mode

The hex trace mode helps the user test and troubleshoot programs. Use the hex trace procedure to get a hexadecimal printout of the data stream sent to the printer. All data, including both control and character data, print in hexadecimal instead of ASCII.

To activate hex trace mode:

1. Press and hold **Tractor** and then turn the printer on.
2. After a few seconds, release **Tractor** and the lights go out.
3. Start your application program. Be sure the printout is similar to the hex trace sample shown. Two hexadecimal digits, followed by a space, are printed for each byte of data sent to the printer.
4. The printer continues to print in hexadecimal until you turn the printer off.

Hex Trace Mode Sample

```

20 20 20 30 20 20 40 20 20 20 20 A0 20 20 B0 20 20 C0 20
20 00 20 20 E0 20 20 F0 00 20 61 20 20 71 20 20 81 20 20
91 20 20 A1 20 20 B1 20 20 C1 20 20 20 32 20 20 42 20 20 52
20 20 62 20 20 72 20 20 82 20 20 20 02 20 20 E2 20 20 F2 00 0A
0A 23 20 20 33 20 20 43 20 20 20 93 20 20 A3 20 20 B3 20 20 C3
20 20 03 20 20 E3 20 20 F3 20 20 20 20 64 20 20 74 20 20 84 20
20 94 20 20 A4 20 20 B4 20 20 20 0A 25 20 20 35 20 20 45 20 20
55 20 20 65 20 20 75 20 20 20 20 20 05 20 20 E5 20 20 F5 00
0A 0A 26 20 20 36 20 20 46 20 20 20 96 20 20 A6 20 20 B6 20 20
C6 20 20 D6 20 20 E6 20 20 F6 20 20 20 0A 28 20 20 38 20 20 48 20
20 20 97 20 20 A7 20 20 B7 20 20 20 0A 28 20 20 38 20 20 48 20
20 59 20 20 68 20 20 78 20 20 20 20 08 20 20 E8 20 20 F8
0D 0A 0A 29 20 20 39 20 20 49 20 20 20 99 20 20 0A 29 20 20 B9 20
20 C9 20 20 D9 20 20 E9 20 20 20 20 20 0A 20 20 6A 20 20 7A 20 20
8A 20 20 9A 20 20 0A 20 20 8A 20 20 20 0A 28 20 20 38 20 20 48
20 20 58 20 20 68 20 20 78 20 20 20 20 0B 20 20 DB 20 20 EB 20 20
FB 0D 0A 0A 2C 20 20 3C 20 20 20 20 20 9C 20 20 AC 20 20 BC
20 20 CC 20 20 DC 20 20 EC 20 20 20 20 5D 20 20 6D 20 20 7D 20
20 8D 20 20 9D 20 20 AD 20 20 20 20 0A 0A 2E 20 20 3E 20 20
4E 20 20 5E 20 20 6E 20 20 7E 20 20 20 20 CE 20 20 DE 20 20 EE 20
20 FE 0D 0A 0A 2F 20 20 3F 20 20 20 20 8F 20 20 9F 20 20 AF 20 20
8F 20 20 CF 20 20 DF 20 20 EF

```

Printer Default Settings

U.S. Defaults

To initialize or reset the printer to the U.S. factory defaults:
(Code page 437 Character Set 1, form length 11 inch)

1. Make sure paper and the ribbon cartridge are installed.
2. Turn the printer off.
3. Open the ribbon access cover.
4. Move the printhead toward the operator panel side of the printer until it stops.
5. Close the ribbon access cover.
6. Press and hold **Tear Off + Load/Unload** while you turn the printer on.
7. Continue holding these buttons until the carrier moves. The operator panel lights blink several times. Once the carrier moves, your settings have been reset to factory defaults.

World Trade Defaults

To initialize or reset the printer to the World Trade defaults:
(Code page 858, Character Set 2, form length 12 inch)

1. Make sure paper and the ribbon cartridge are installed.
2. Turn the printer off.
3. Open the ribbon access cover.
4. Move the printhead toward the operator panel side of the printer until it stops.
5. Close the ribbon access cover.
6. Press and hold **Tear Off + Tractor** while you turn the printer on.
7. Continue holding these buttons until the carrier moves. The operator panel lights blink several times. Once the carrier moves, your settings have been reset to factory defaults.

Clearing Paper Jams

Cut Sheet Jams

To clear cut form paper jams:

1. Turn the printer off.
2. Set the forms thickness lever to position 7.
3. Push the paper select lever down to the continuous forms position.
4. Gently pull out the sheet of paper from the front of the printer.
5. Remove the ribbon access cover to clear any torn pieces of paper.
6. Set the paper select lever to the cut forms position.
7. Set the forms thickness lever to the proper setting for the type of paper you are using. Refer to the *24xx User's Guide*.

Continuous Forms Jams

1. Turn the printer off.
2. Detach any continuous forms already printed.
3. Set the forms thickness lever to position 7.
4. Tear the continuous forms off at the perforation line before the forms enter the printer.
5. If using the tractor in the push position, open the front cover. (Skip this step if you are using the optional Tractor 2 Feeder.)
6. Open the left and right tractor doors.
7. Lift the paper from tractor pins.
8. Carefully pull out the paper.
9. Remove the ribbon access cover to clear any torn paper.
10. Remove any torn perforation strips or bits of paper from the paper path.

4. Repair Information

This chapter contains adjustments and removal procedures. Whenever parts are replaced, make sure that all adjustments are correct by running diagnostics procedures and checking adjustments as needed.

Handling ESD-Sensitive Parts

Many electronic products use parts that are known to be sensitive to electrostatic discharge (ESD). To prevent damage to ESD-sensitive parts, follow the instructions below in addition to all the usual precautions, such as turning off power before removing logic boards:

- Keep the ESD-sensitive part in its original shipping container (a special “ESD bag”) until you are ready to install the part into the printer.
- Make the least-possible movements with your body to prevent an increase of static electricity from clothing fibers, carpets, and furniture.
- Put the ESD wrist strap on your wrist. Connect the wrist band to the system ground point. This discharges any static electricity in your body to the printer.
- Hold the ESD-sensitive part by its edge connector shroud (cover); do not touch its pins. If you are removing a pluggable module, use the correct tool.
- Do not place the ESD-sensitive part on the printer cover or on a metal table; if you need to put down the ESD-sensitive part for any reason, first put it into its special bag.
- Printer covers and metal tables are electrical grounds. They increase the risk of damage because they make a discharge path from your body through the ESD-sensitive part. (Large metal objects can be discharge paths without being grounded.)
- Prevent ESD-sensitive parts from touching other personnel. Install printer covers when not working on the printer, and do not put unprotected ESD-sensitive parts on a table.
- Keep all ESD-sensitive parts in a grounded metal cabinet (case).
- Low humidity increases static electricity during cold-weather.

Adjustments

CAUTION: Be sure to unplug the power cord whenever you are working on the printer with one of the covers removed.

Printhead-to-Platen Gap Adjustment

Perform the printhead-to-platen gap adjustment after replacing the carrier, platen, lower pinch roller, ribbon drive rack gear, left side frame, right side frame, paper separator, lower feed roller, or paper guide.

1. Turn the printer off and remove all covers, with the exception of the bottom cover. See **“Covers, Removals” on page 4-5**.
2. Remove the ribbon cartridge and paper.
3. Remove the Lock Tite (red) from the gap adjust bushings on both the left and right side of the printer.
4. Set the form thickness lever to position 1, by pushing it toward the back of the printer as far as it will go.
5. Move the printhead to the left edge of the rubber on the platen.
6. Shift the left gap adjust bushing clockwise as far as it will go.
7. Shift the right gap adjust bushing counterclockwise as far as it will go.

Note: At this time, the nose of the printhead should be touching the platen.

- Using a feeler gauge [1], slowly adjust the left gap adjust bushing [2] counterclockwise, until a gap of (within 0.33 and 0.37 mm) exists between the printhead [3] and the platen.

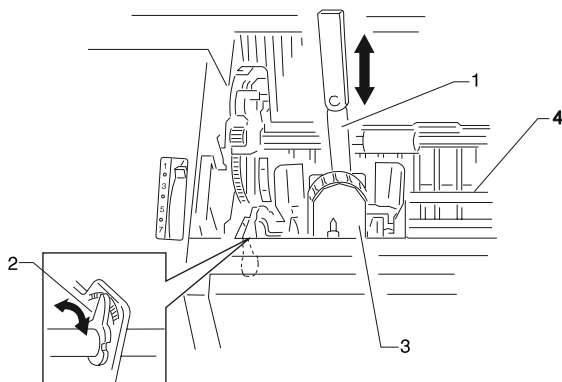

- Move the printhead to the right edge of the rubber on the platen and using a feeler gauge [1], slowly adjust the right gap adjust bushing [2] clockwise, until a gap of (within 0.33 and 0.37 mm) exists between the printhead [3] and the platen.

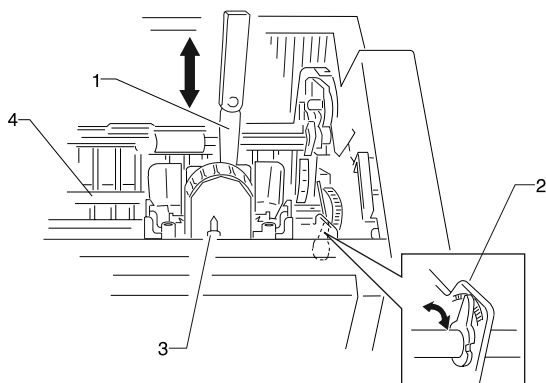

- After adjusting both left and right gap adjust bushings, push the printhead to the center of the platen and verify a gap of within (0.33 and 0.37 mm) exists between the printhead and the platen.

Note: For maximum print quality, adjust the head gap on both the left and right sides of the printer to within +/- 0.01mm. If the gap value exceeds the specified range, return to step 4 and re-adjust both left and right gap adjust bushings.

11. After confirming the head gap is within the specified range for all (left, right and center) printhead positions, apply Lock Tite on both bushings.

Bidirectional Print Adjustment

After replacing any mechanical part which affects the operation of the logic board or the carrier, perform the following procedure to adjust the bidirectional print. This adjustment cannot be completed if the printer runs out of paper, so be sure to use continuous forms.

1. Through the Setup Menu, be sure the Default Macro is set to Disabled.
2. Turn the printer off.
3. Open the operator panel cover to access layer two.
4. Press and hold the **Pitch** key, while turning the printer on.
 - The draft alignment bars print.
 - The current value is the number printed below the bars.
5. To set Draft, select the best alignment from the alignment bars in rows 01 - 11.
6. Press **Micro**↑ or **Micro**↓ to select the best alignment by number, or keep the current value. After selecting, the printer prints a single row showing the current alignment setting.
7. Press **Set TOF** to save the selection.
 - The printer automatically prints the alignment bars for NLQ.
 - The current value is the number printed below the bars.
8. To set NLQ, select the best alignment from the alignment bars in rows 01 - 11. The current value is the number printed below the bar.
9. Press **Micro**↑ or **Micro**↓ to select the best alignment by number, or keep the current value. After selecting, the printer prints a single row showing the current alignment setting.
10. Press **Set TOF** to save the selection.
11. Close the operator panel cover. The printer returns to Ready.

Removal Procedures

CAUTION: Be sure to unplug the power cord whenever you are working on the printer with one of the covers removed.

Covers, Removals

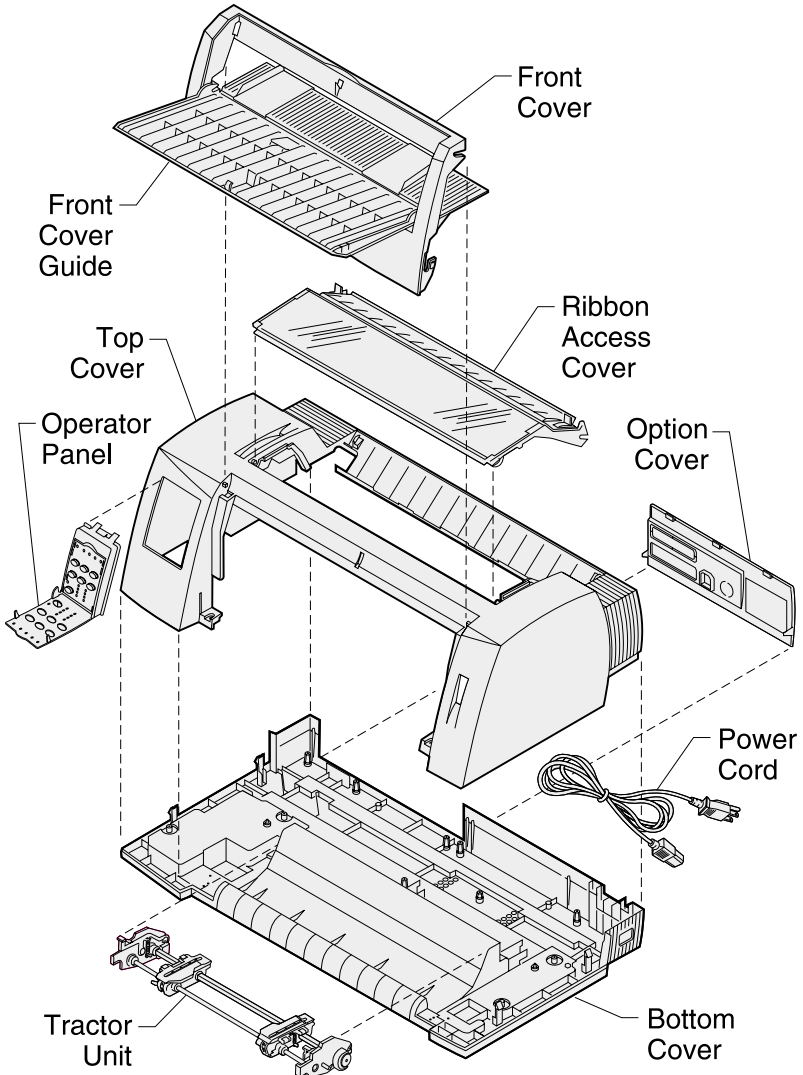

Covers, Front Removal

1. Rotate the front cover out and up about three inches from the bottom of the printer.
2. Push the front cover up and out of the printer.

Covers, Ribbon Access Removal

1. Pull both gray spring loaded ribbon access cover release latches [A], on either side of the ribbon access cover, up toward the front of the printer.

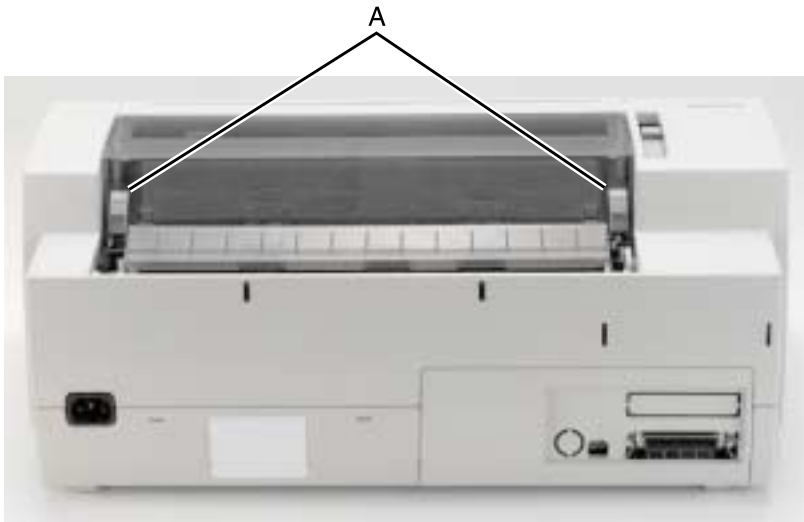

2. Lift the ribbon access cover up and out of the printer.

Note: When replacing the ribbon access cover, be sure to hook the front hinge points on either side of the ribbon access cover first and lower the cover into place. Be sure that both gray spring loaded ribbon access cover latches snap and lock.

Covers, Option Removal

1. From the bottom, pull the option cover [A] outward and up, removing it from the printer.



A

Covers, Top Removal

1. Turn the printer off and disconnect the power cord at the printer.
2. Remove the tractor assembly, if it is installed in the pull tractor position, by pressing the locking levers and pulling the tractor assembly out of the printer.
3. Remove the ribbon access cover. Go to “**Covers, Ribbon Access Removal**” on page 4-6.
4. Remove the front cover. Go to “**Covers, Front Removal**” on page 4-6.
5. Remove the option cover. Go to “**Covers, Option Removal**” on page 4-7.

Note: With the option cover removed, you can see the operator panel cable attached to the logic board.

6. Disconnect the operator panel cable from the logic board.
7. Remove the two screws [A] from each side of the front cover area.

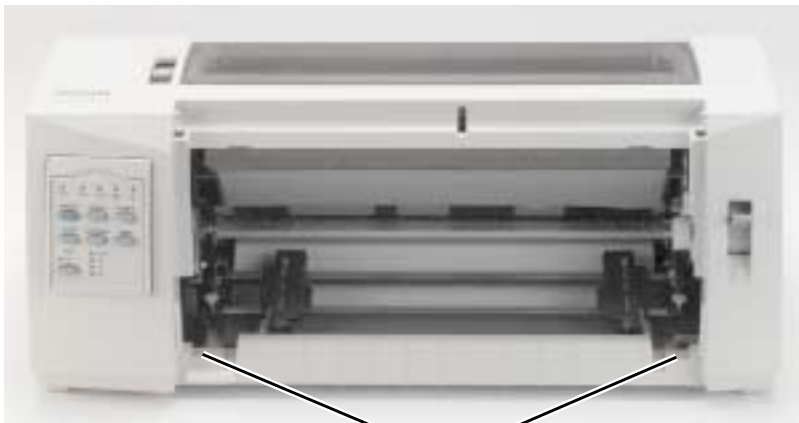

A

24xx

8. Turn the printer upside down.
9. Insert a flat blade screwdriver into each of the four holes [A] in the bottom cover, releasing the top cover from the bottom cover.

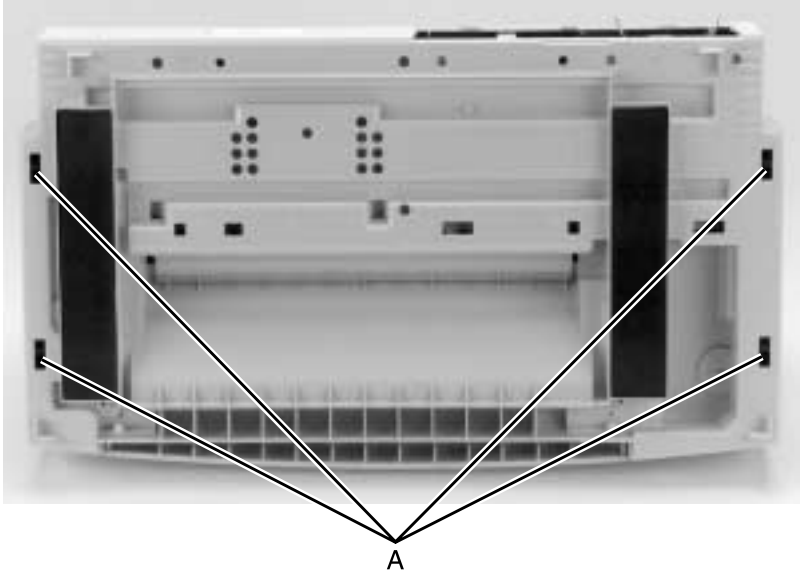

10. Turn the printer right side up and insert a flat blade screwdriver into each of the two holes [A] in the back of the top cover.

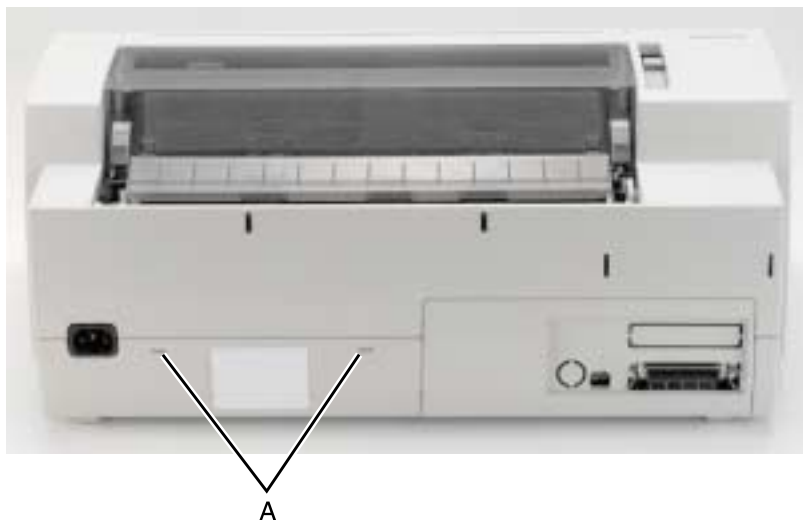

11. Lift the top cover up and over the print unit assembly.

Note: When replacing the top cover, be sure the operator panel cable is correctly aligned and inserted securely into the logic board. Damage to the operator panel cable may cause failure of other electrical components in the printer.

Covers, Operator Panel Assembly Removal

1. Remove the top cover. Go to “**Covers, Top Removal**” on **page 4-8**.
2. Disconnect the operator panel cable from the operator panel card, on the inside of the top cover.
3. Push down on the two latches [A] at the top of the operator panel on the inside of the top cover, as shown.

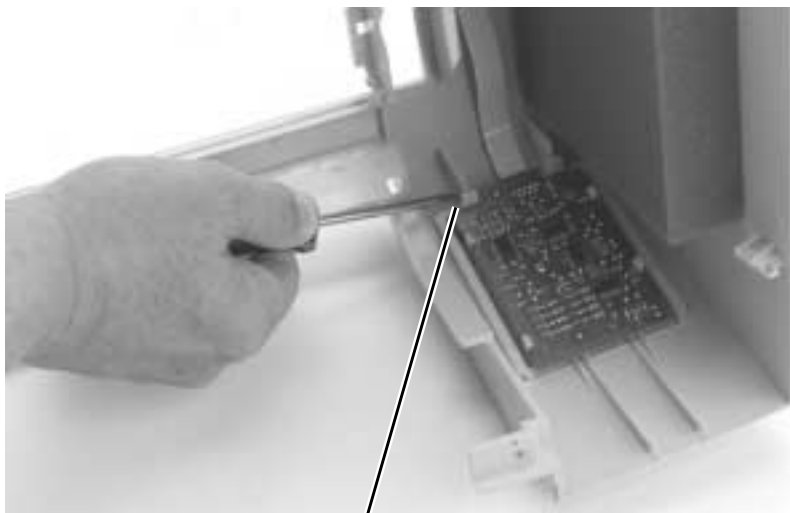

A

4. While holding the latches down, push the operator panel out of the top cover, toward the bottom of the cover.

Note: Be sure the operator panel cable is correctly inserted during replacement, into both the operator panel card and the logic board.

Covers, Bottom Removal

1. Remove the top cover. Go to **“Covers, Top Removal” on page 4-8.**
2. Remove the logic board. Go to **“Logic Board Removal” on page 4-14.**
3. Remove the power supply unit. Go to **“Power Supply Removal” on page 4-15.**
4. Remove the print unit. Go to **“Print Unit Removal” on page 4-28.**

Electronics Removals

EPRM Removal

1. Remove the options cover [A], by pulling it outward, up and out of the printer.

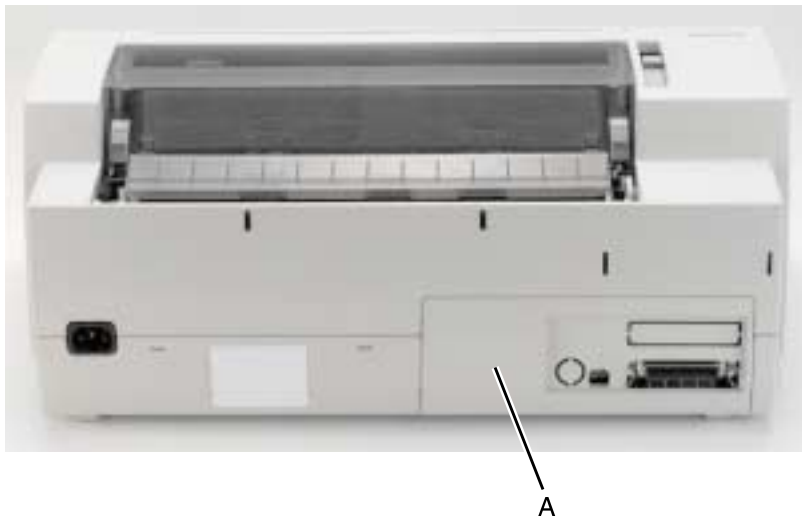

2. Remove the EPROM module.

Note: When replacing the EPROM module, be sure the notch on the module is toward the front of the printer.

Logic Board Removal

1. Remove the top cover. Go to **“Covers, Top Removal” on page 4-8.**
2. Disconnect all cables connected to the logic board. Go to **“Logic Board (9w & 24w)” on page 5-3,** for connector location details.

Note: Do not twist the flexible cable when disconnecting the printhead cable(s).

3. Remove the top screw [A] from the serial interface card bracket.

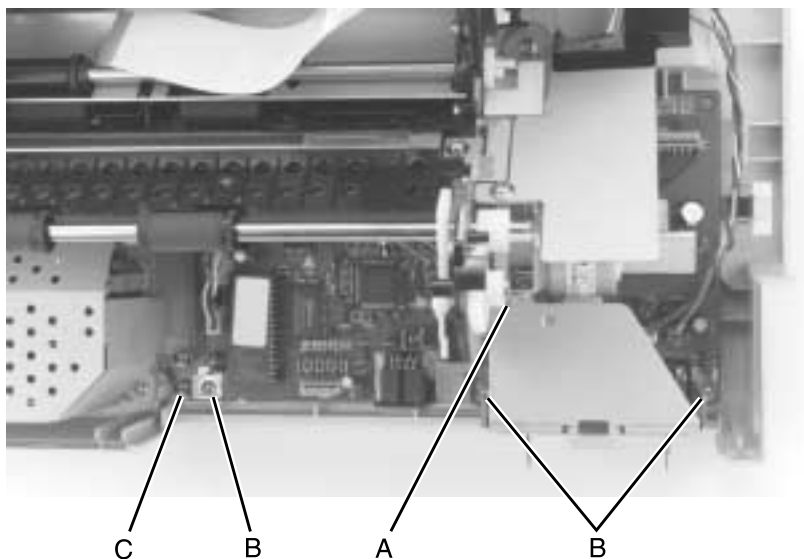

4. Remove the three screws [B] securing the logic board to the bottom cover. Take care not to lose the ground clips which must be replaced between the ground plate and the board.
5. Remove the ground clip screw [C] from the bottom cover.
6. Remove the logic board.

Note: Be sure to check the Bidirectional Print Adjustment after installing the logic board. Go to **“Bidirectional Print Adjustment” on page 4-4.**

Power Supply Removal

CAUTION: The power supply may be hot.

1. Turn off the printer and disconnect the power cord at both ends.
2. Remove the top cover. Go to **“Covers, Top Removal” on page 4-8.**
3. Remove the print unit. Go to **“Print Unit Removal” on page 4-28.**

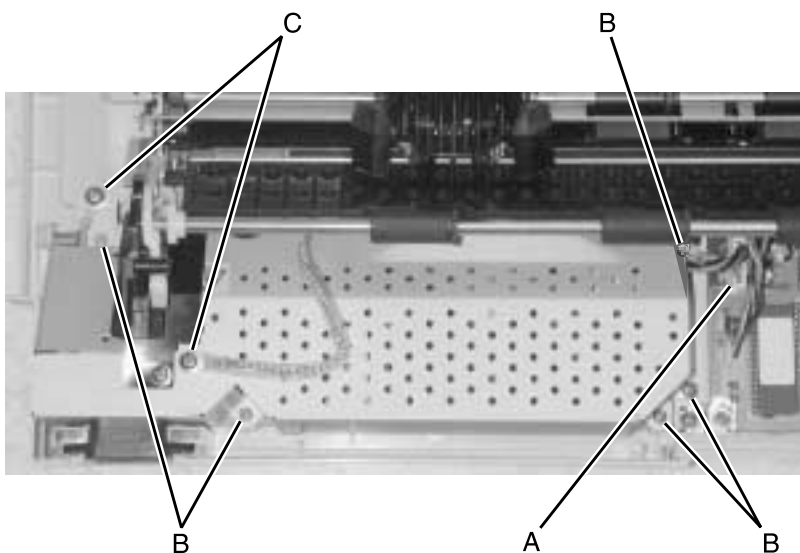

4. Disconnect the power supply cable [A].
5. Remove the five screws [B] securing the power supply to the bottom cover. Take care not to lose the ground clips which must be replaced between the ground plate and the board.
6. Remove the two ground wire screws [C].
7. Remove the power supply.

Carrier Removals

Carrier Removal

1. Remove the top cover. Go to **“Covers, Top Removal” on page 4-8.**
2. Remove the printhead from the carrier. Go to **“Printhead Removal” on page 4-27.**
3. Loosen the carrier belt:
 - a. Loosen the tension screw [A].
 - b. Remove tension from the belt, by pulling up on the belt.
 - c. Tighten the tension screw. Loosening the screw tightens the belt.



A

4. Remove the retaining wire [A] from the left side of the carrier shaft.

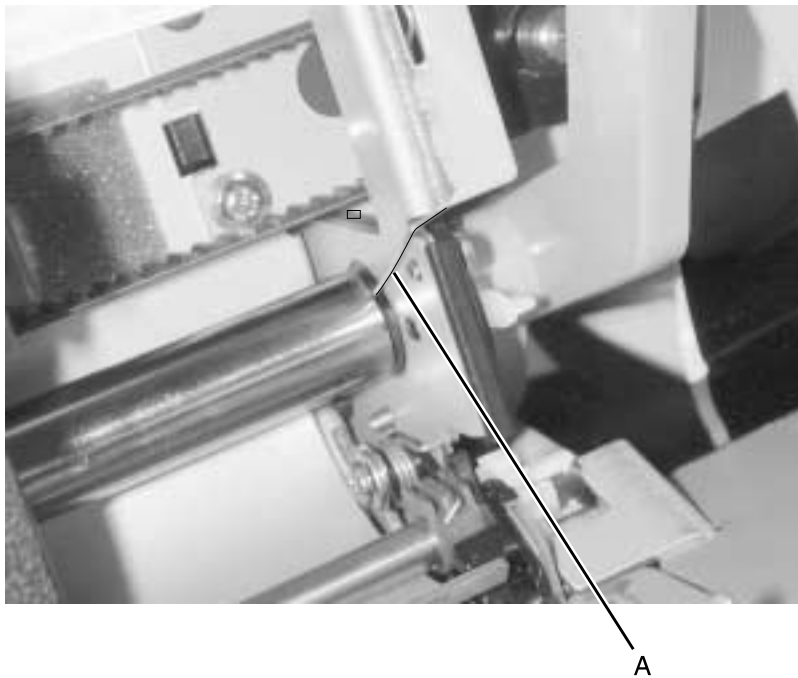

5. Remove the screw [A] from the forms thickness lever and remove the lever.

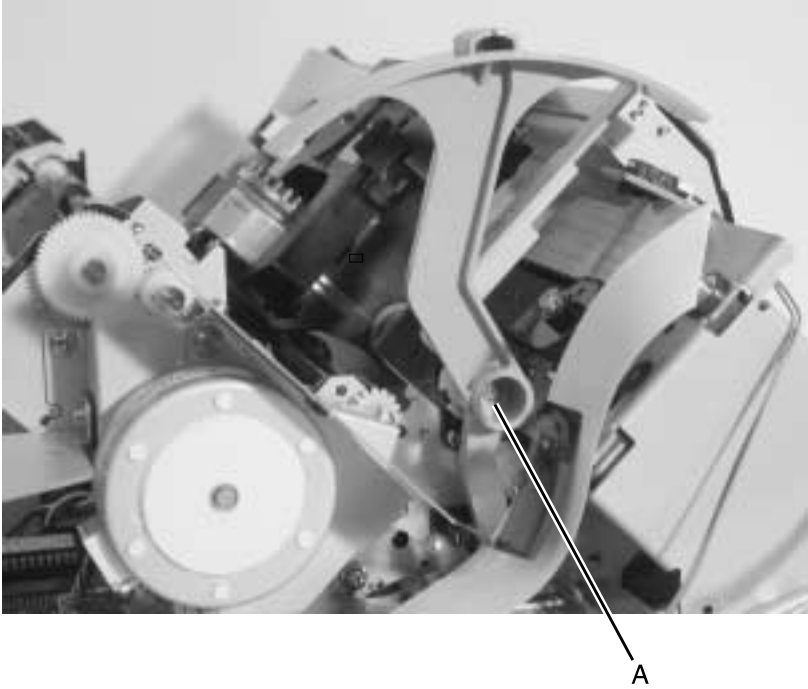

6. Remove the lower carrier motor mount screw [A].
7. Remove the two screws [B] from the carrier shaft bushing bracket on the left end of the carrier shaft and remove the bracket.

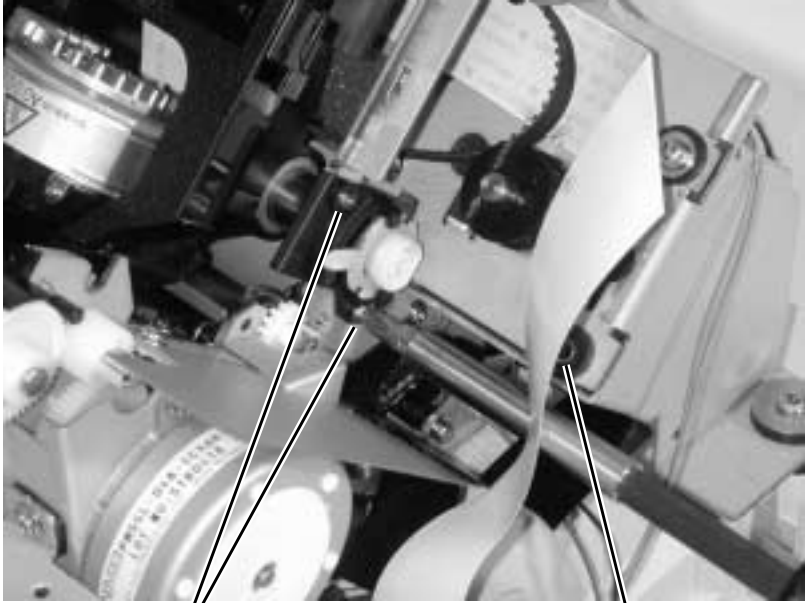

B

A

8. Remove the E-clip from the right side of the carrier shaft.

9. Push the carrier shaft [A] from the right side and out the left side of the printer.

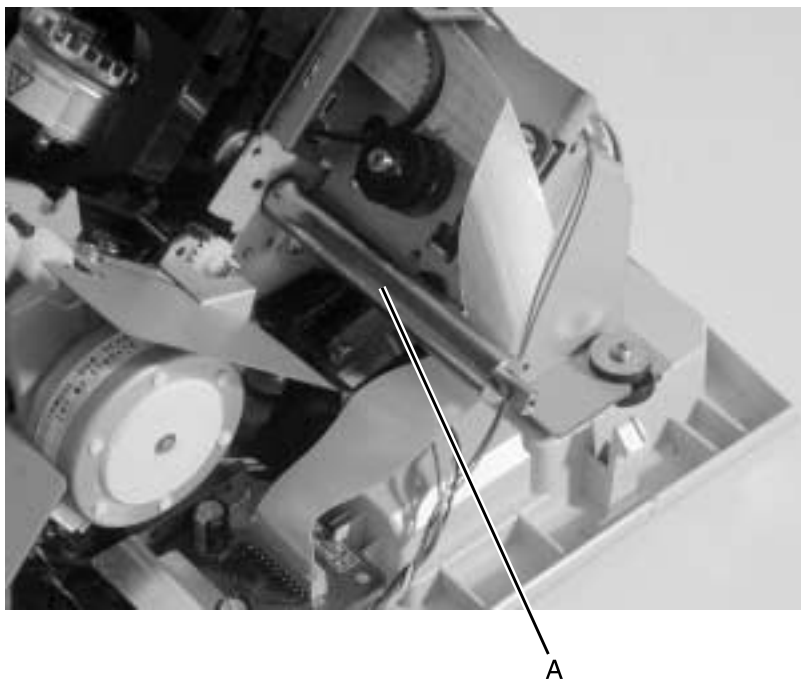

10. Remove the carrier from the printer.

Note: Following replacement, perform the Printhead-to-Platen Gap Adjustment. Go to **“Printhead-to-Platen Gap Adjustment”** on **page 4-2**.

Carrier, Motor Assembly Removal

1. Remove the top cover. Go to “**Covers, Top Removal**” on **page 4-8**.
2. Loosen the carrier belt
 - a. Loosen the tension screw [A].
 - b. Remove tension from the carrier belt, by pulling up on the belt.
 - c. Tighten the tension screw. Loosening the screw tightens the belt.:

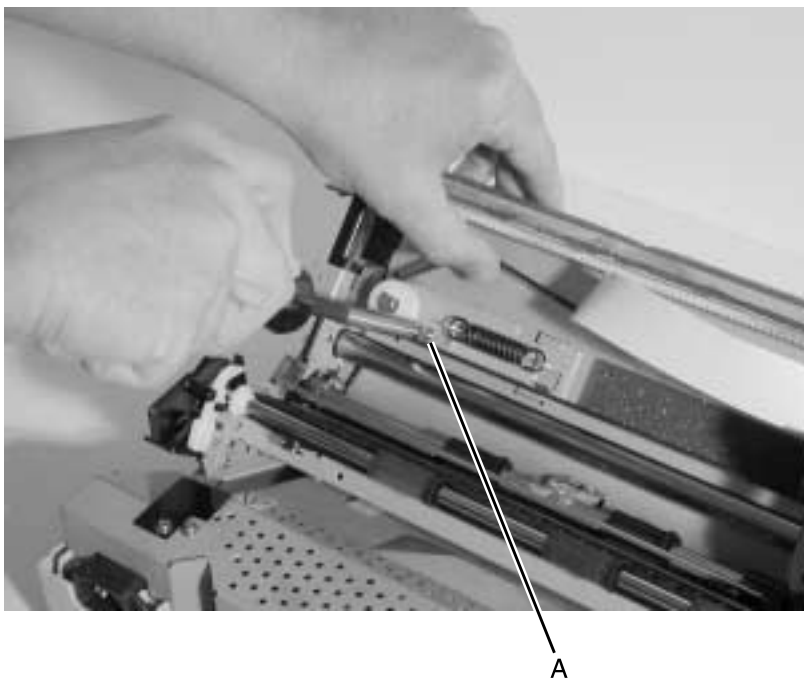

3. Slip the belt off the carrier motor pulley.

4. Remove the screw [A] from the forms thickness lever and remove the lever.

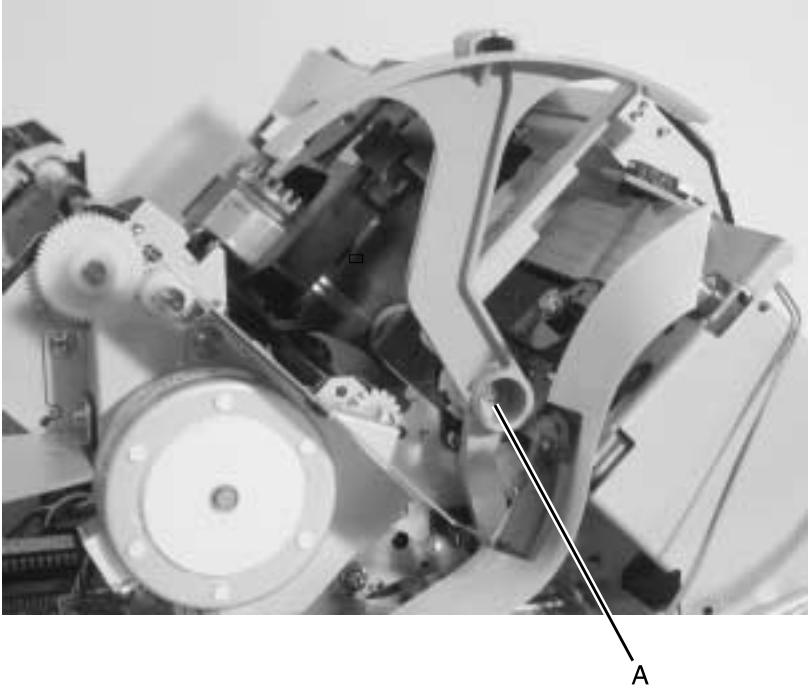

5. Remove the screw [A] securing the carrier motor bracket to the bottom cover.

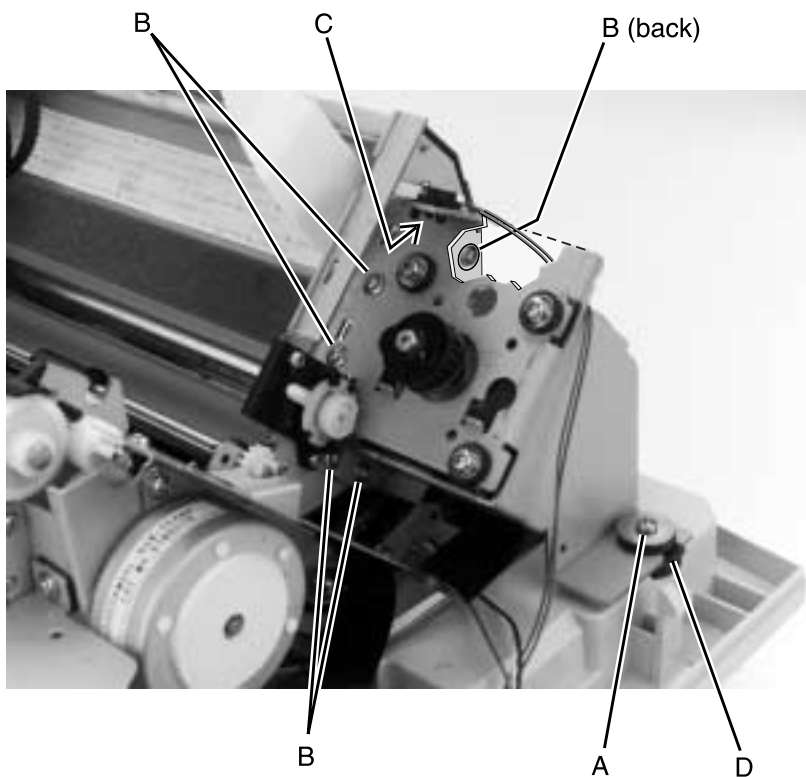

6. Disconnect the printhead cable from the logic board and move it back and out of the way, as shown.
7. Remove the five screws [B] securing the carrier motor bracket to the print unit.
8. Remove the home position sensor [C] from the top of the carrier motor bracket by pinching the clips underneath the bracket.
9. Remove the carrier motor bracket from the print unit by pulling up and out on the rubber grommet [D] between the motor bracket and the bottom cover.
10. Disconnect the carrier motor cable from the logic board.
11. Remove the carrier motor from the motor bracket.

Paper Handling Removals

Paper Select Lever Removal

1. Remove the top cover. Go to **“Covers, Top Removal” on page 4-8.**
2. Release the latch and remove the paper select lever from the right side frame.

Paper Feed Motor Removal

1. Remove the top cover. Go to **“Covers, Top Removal” on page 4-8.**
2. Remove the two screws [A] from the paper feed motor bracket.

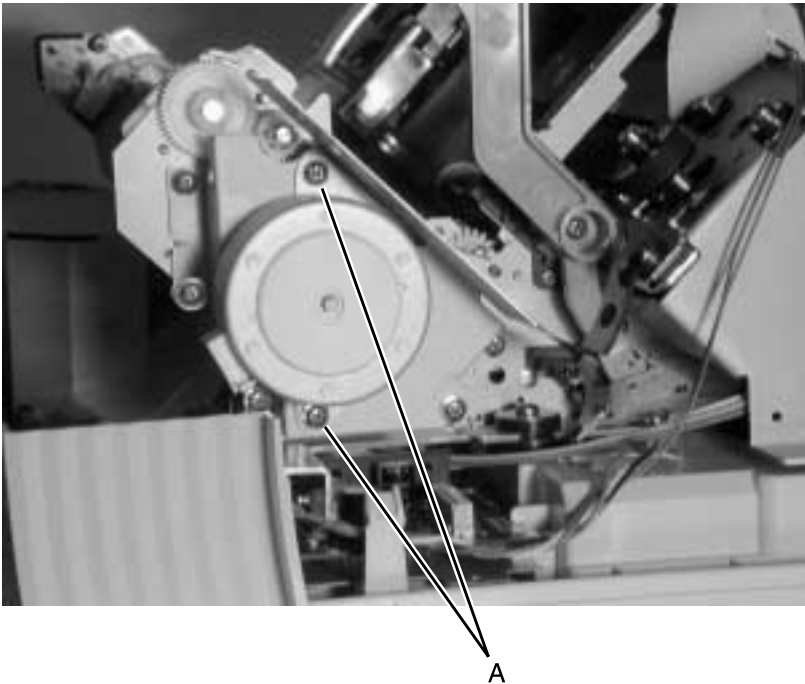

3. Remove the motor.
4. Disconnect the paper feed motor cable from the logic board.

Form Thickness Lever Removal

1. Remove the top cover. Go to “**Covers, Top Removal**” on **page 4-8**.
2. Remove the screw [A] from the lever and remove the form thickness lever.

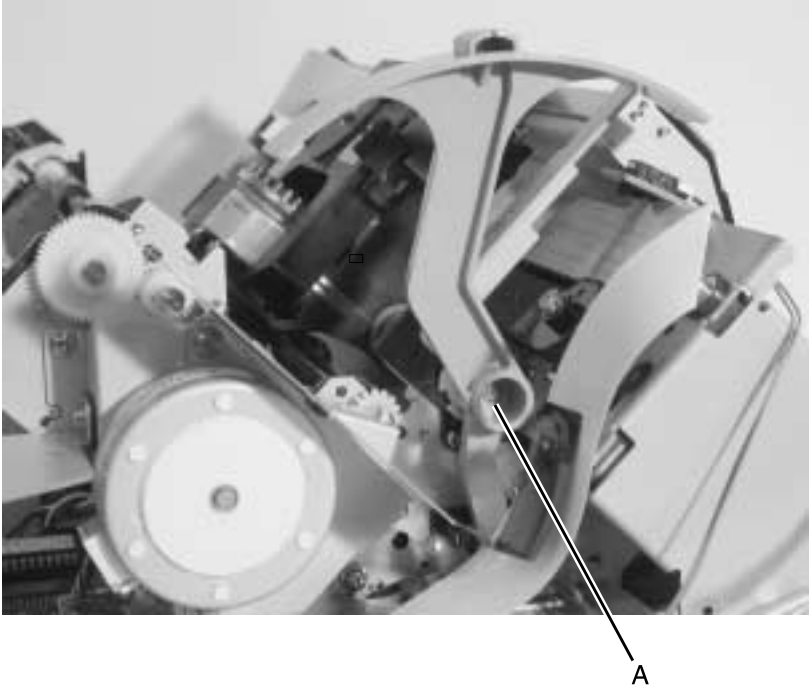

Print Handling Removals

Platen Removal

1. Remove the top cover. Go to **“Covers, Top Removal”** on page 4-8.
2. Remove the two platen screws [A] from each end of the platen.

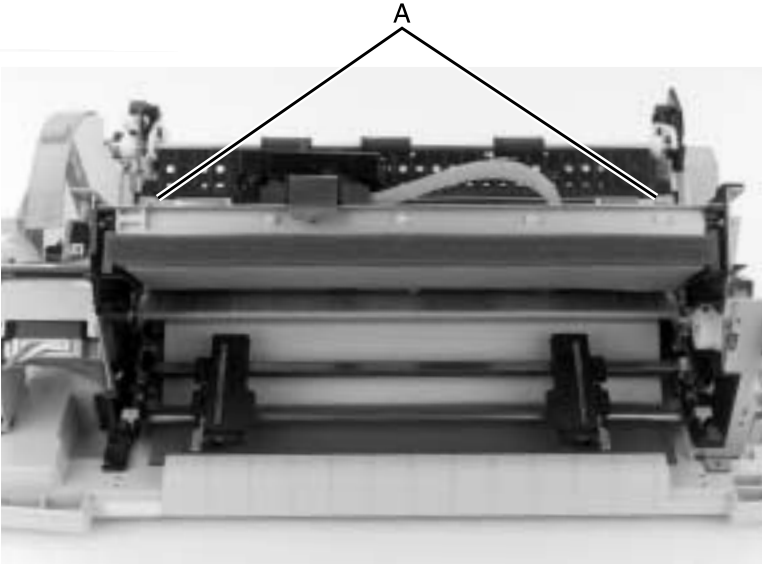

3. Remove the platen from the paper tray.
4. Perform the Printhead-to-Platen Gap adjustment. Go to **“Printhead-to-Platen Gap Adjustment”** on page 4-2.

Printhead Removal

1. Turn the printer off.
2. Disconnect the power cord at the printer and allow the printhead to cool for 15 minutes, prior to handling.
3. Set the form thickness lever to position 7.
4. Remove the ribbon access cover. Go to **“Covers, Ribbon Access Removal” on page 4-6.**
5. Remove the ribbon cartridge.
6. Squeeze the printhead latches together while pulling the printhead up and out of the printer.
7. Disconnect the printhead cable(s) from the printhead.

Reassembly Note: Be sure the printhead cables are correctly aligned and secured. Be sure to perform the Printhead-to-Platen Gap Adjustment procedure. Go to **“Printhead-to-Platen Gap Adjustment” on page 4-2.**

Printhead Cables Removal

WARNING: Be careful not to damage the printhead cable(s) as they are secured with double-sided adhesive tape.

1. Remove the top cover. Go to **“Covers, Top Removal” on page 4-8.**
2. Remove the printhead. Go to **“Printhead Removal” on page 4-27.**
3. Release the printhead cables from the flexible cable holders.
4. Disconnect the printhead cables from the logic board.

Note: Be sure the printhead cables are correctly aligned and secured. They must be flat, with no twists.

Print Unit Removal

1. Remove the top cover. Go to **“Covers, Top Removal” on page 4-8.**
2. Disconnect all cables from the logic board, except the power supply cable.
3. Remove the screw from the form thickness lever and remove the lever.
4. Remove the two grommet anchored screws [A] from the left side of the print unit.

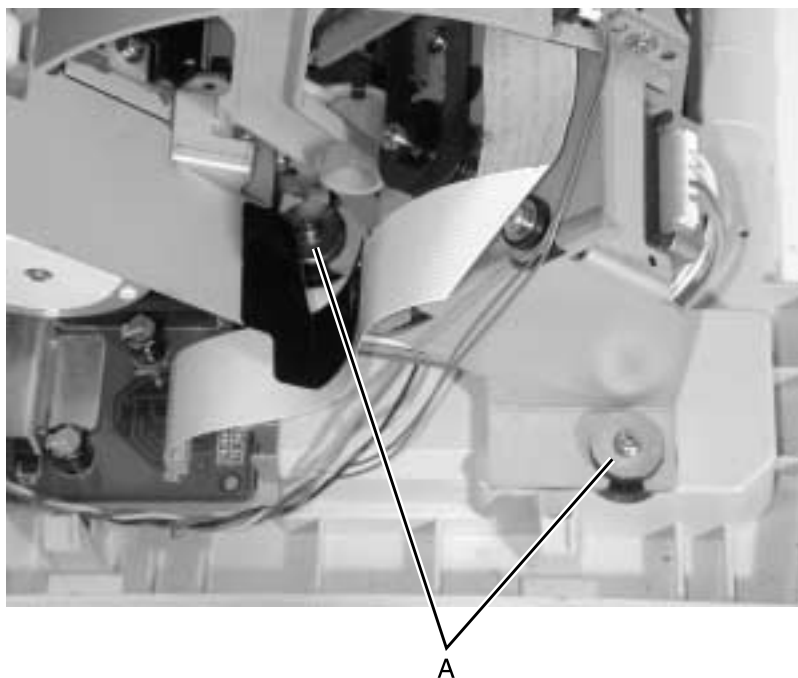

5. Remove the two grommet anchored screws [A] from the right side of the print unit.

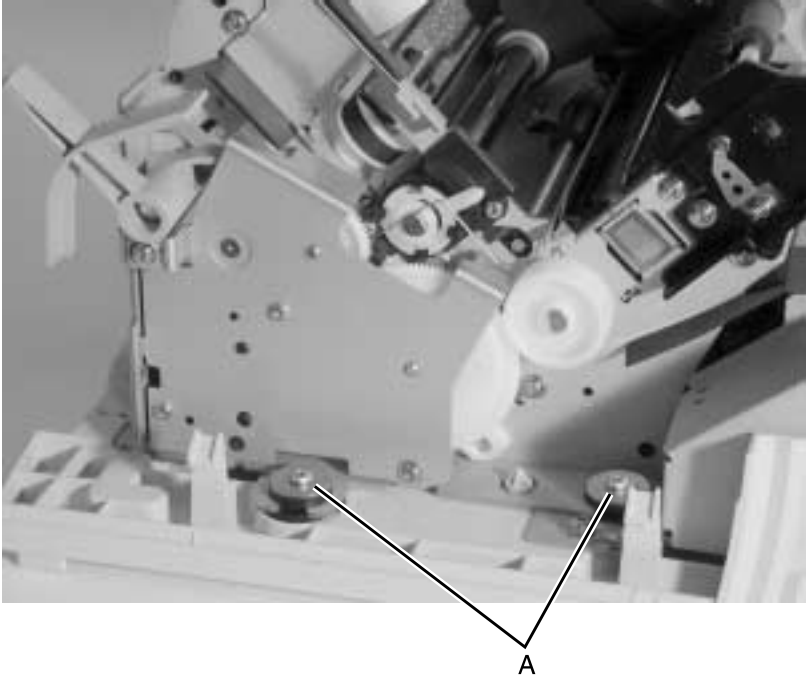

6. Remove the print unit from the bottom cover, by pulling up forcefully on both sides of the print unit.

Ribbon Drive Rack Gear Removal

1. Remove the top cover. Go to **“Covers, Top Removal” on page 4-8.**
2. Remove the carrier. Go to **“Carrier Removal” on page 4-16.**
3. Unsnap the white plastic end stop [A] from the top left side of the print unit.

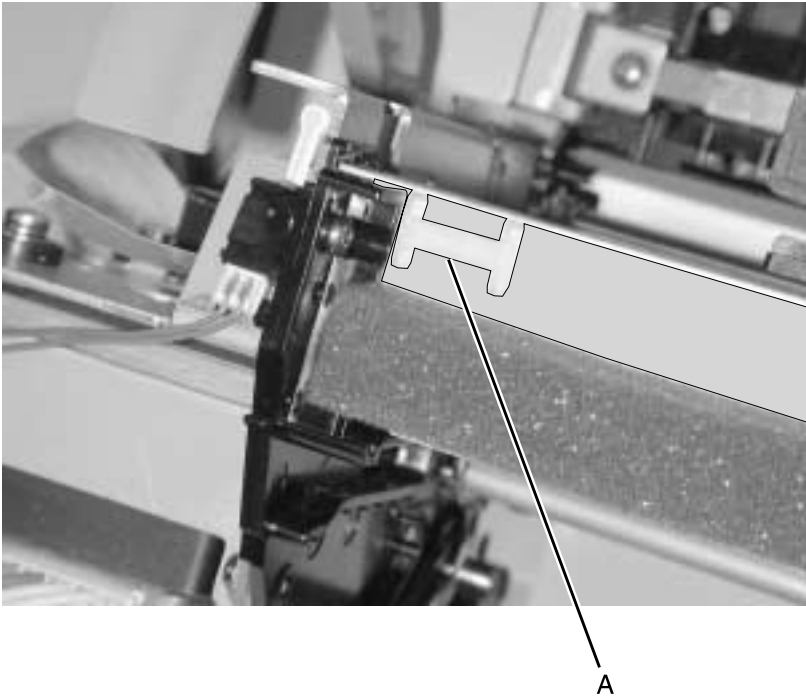

4. Unlatch the left side of the rack from the top of the print unit.
5. Slide the rack to the right and out of the print unit.

Gears Removals

Left Side Gears Removal

1. Remove the top cover. Go to **“Covers, Top Removal”** on **page 4-8**.
2. Remove the three screws [A] from the serial interface card bracket.

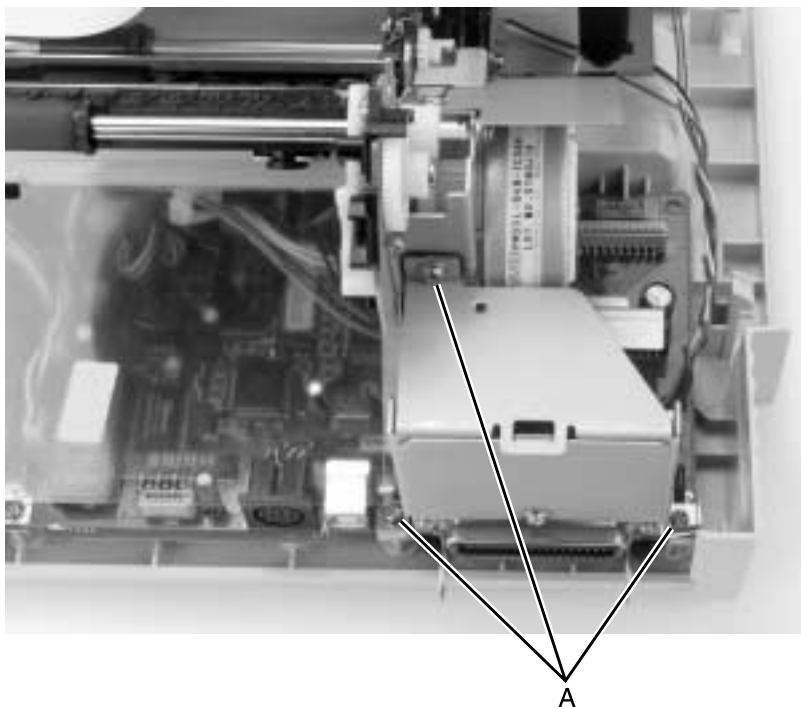

3. Remove the four screws [A] from the paper feed motor bracket assembly.

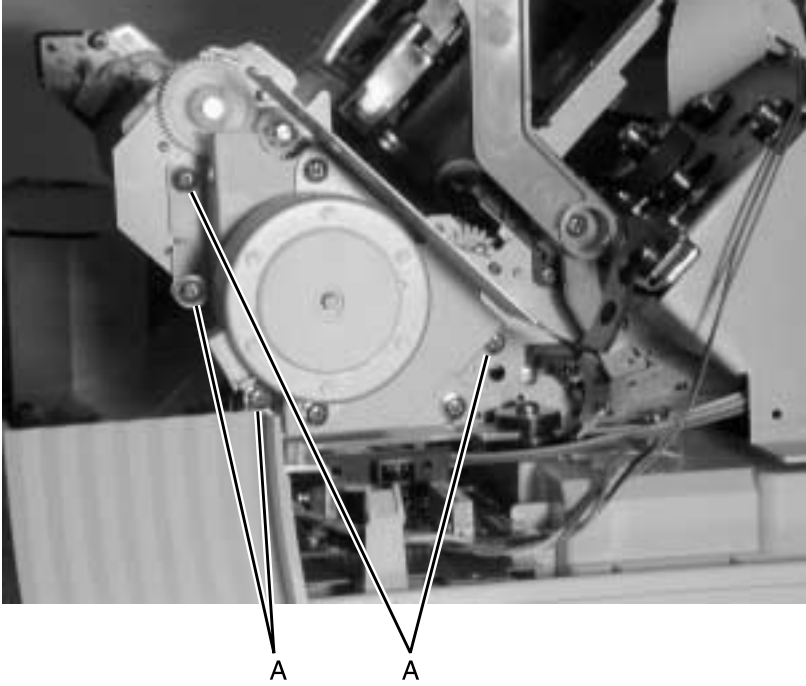

4. Remove the paper feed motor bracket assembly, exposing the gears, as shown.



Right Side Gears, Sub Frame Removal

1. Remove the top cover. Go to **“Covers, Top Removal”** on **page 4-8**.
2. Unhook the wire retainer [A] from the carrier shaft.

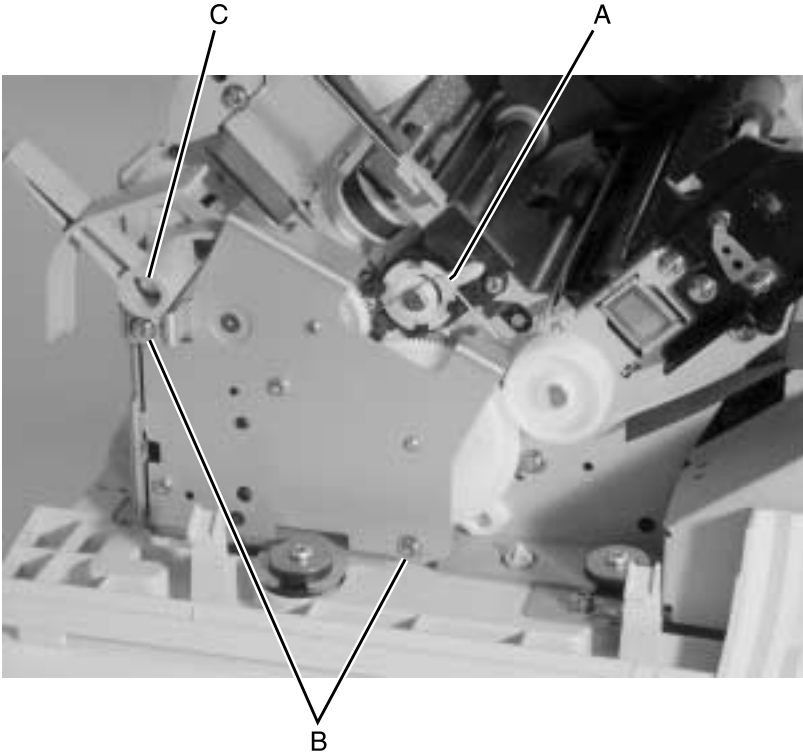

3. Remove the two screws and washers [B] from the sub frame.
4. Remove the paper select lever [C].

24xx

5. Remove the sub frame exposing the right side gears [A], as shown.

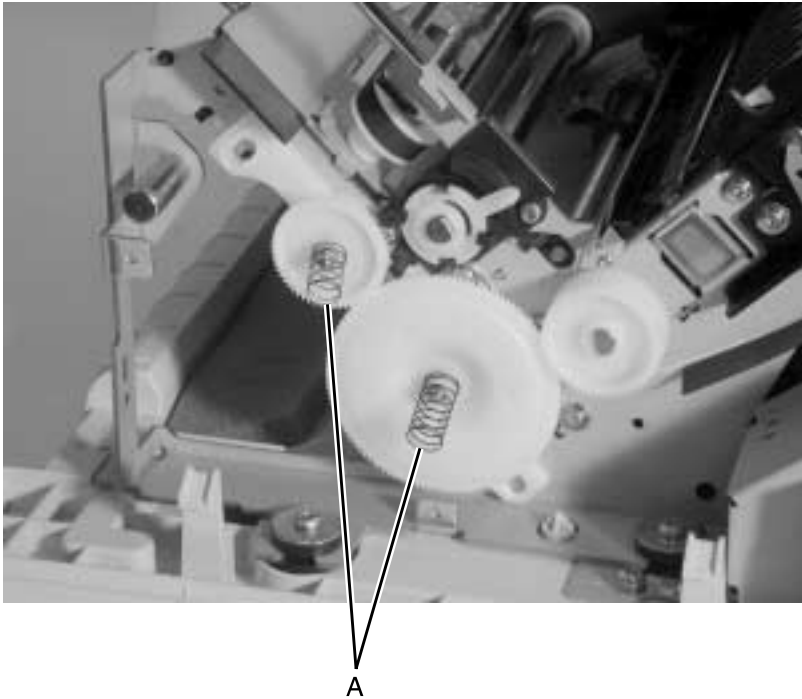

Rollers Removals

Roller, Upper Feed Removal

1. Remove the top cover. Go to **“Covers, Top Removal”** on **page 4-8**.
2. Remove the screw from the print cable shield and remove the shield.
3. Remove the gear from the left end of the upper feed roller, as shown.

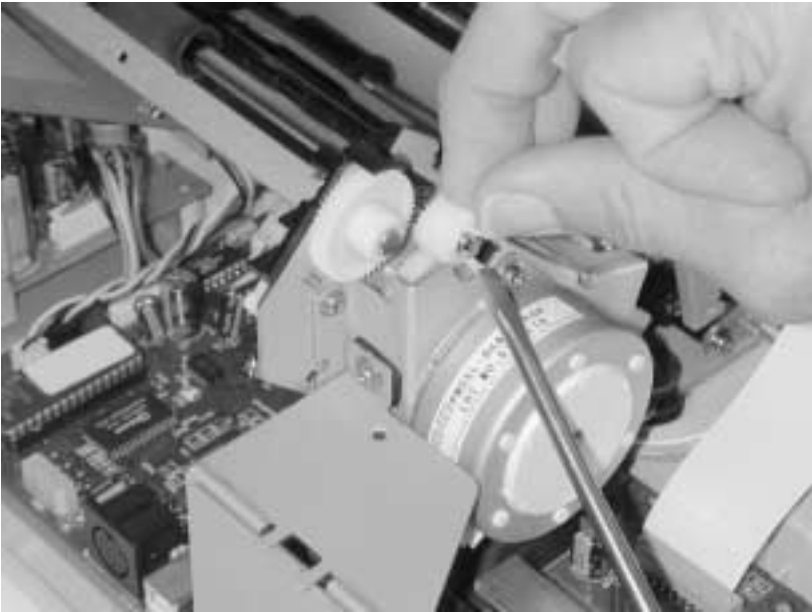

4. Remove the two screws [A] from the right upper feed roller bracket. One screw also retains the upper feed roller ground clip.

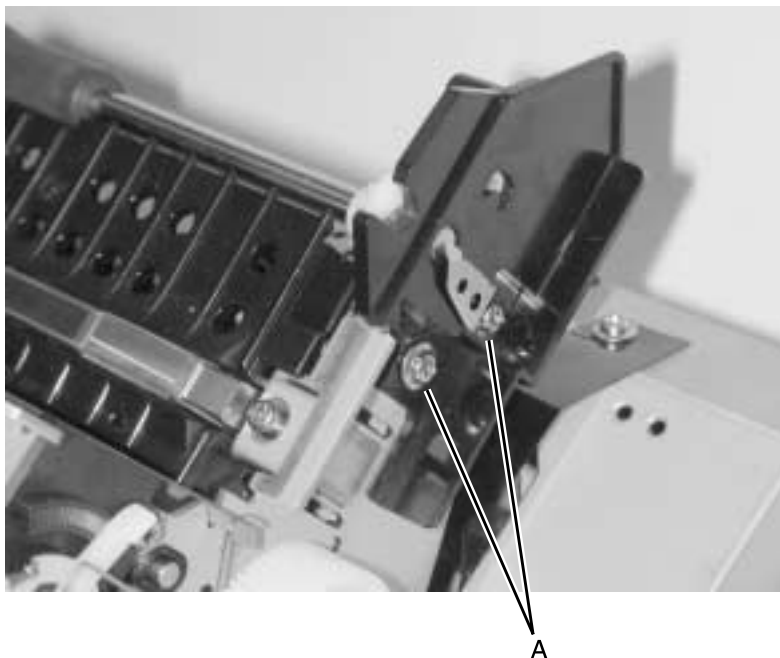

5. Pull the upper feed roller from the left bracket and out of the printer.
6. Be sure to perform the Printhead-to-Platen Gap Adjustment procedure. Go to **“Printhead-to-Platen Gap Adjustment”** on **page 4-2**.

Roller, Lower Pinch Removal

1. Remove the top cover. Go to **“Covers, Top Removal” on page 4-8.**
2. Slide the carrier to the far left of the printer.
3. Remove the four screws [A] from the paper feed motor bracket.

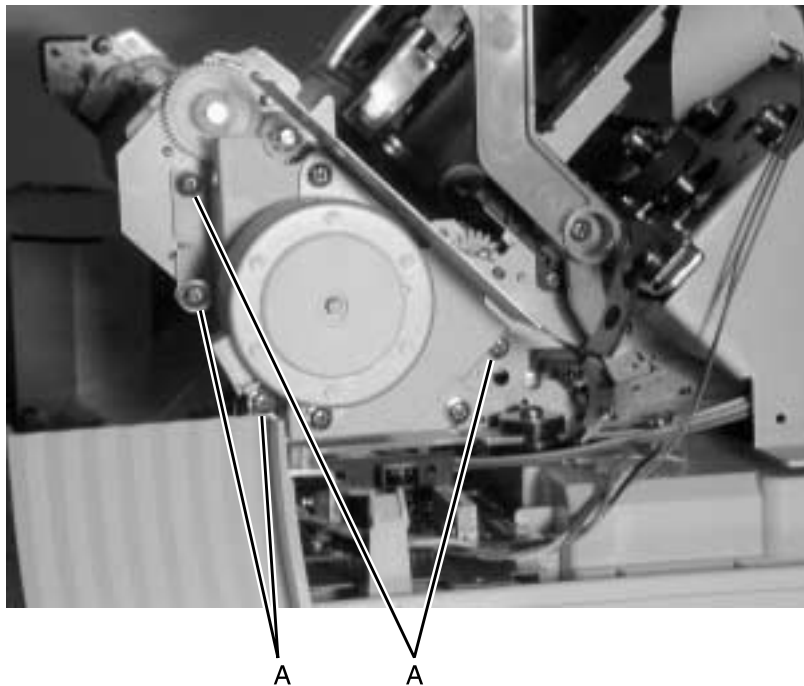

4. Remove the screw from the top of the serial interface card bracket.
5. Disconnect the paper feed motor cable from the logic board and remove the paper feed motor and bracket from the printer.
6. Slide the carrier to the left side of the printer.

7. Unhook the spring clip [A] from the right end of the lower pinch roller shaft and push it off the gray slotted spring block [B] toward the back of the printer, as shown.

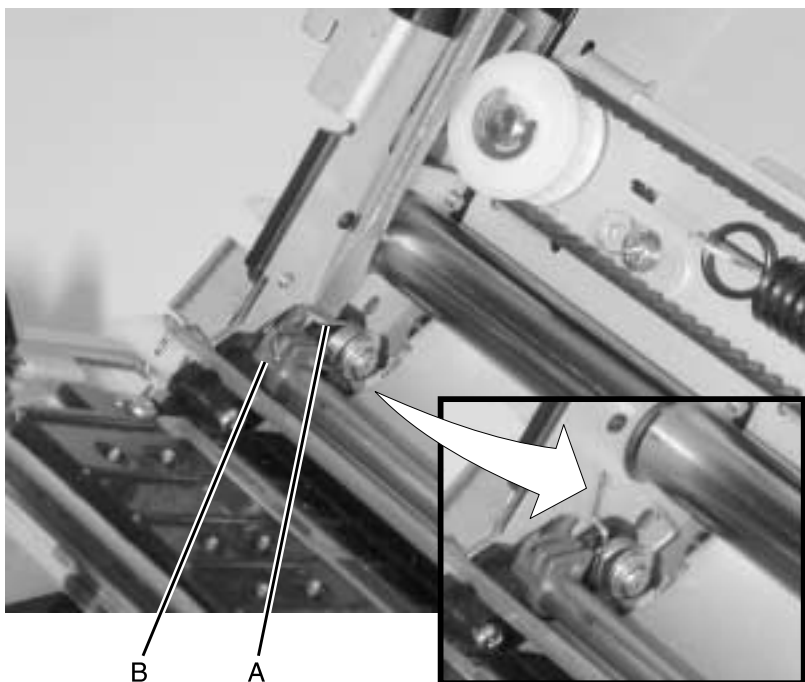

8. Slide the carrier to the right side of the printer.

9. Unhook the spring clip [A] from the left end of the lower pinch roller shaft and push it off the gray slotted spring block [B] toward the back of the printer, as shown.

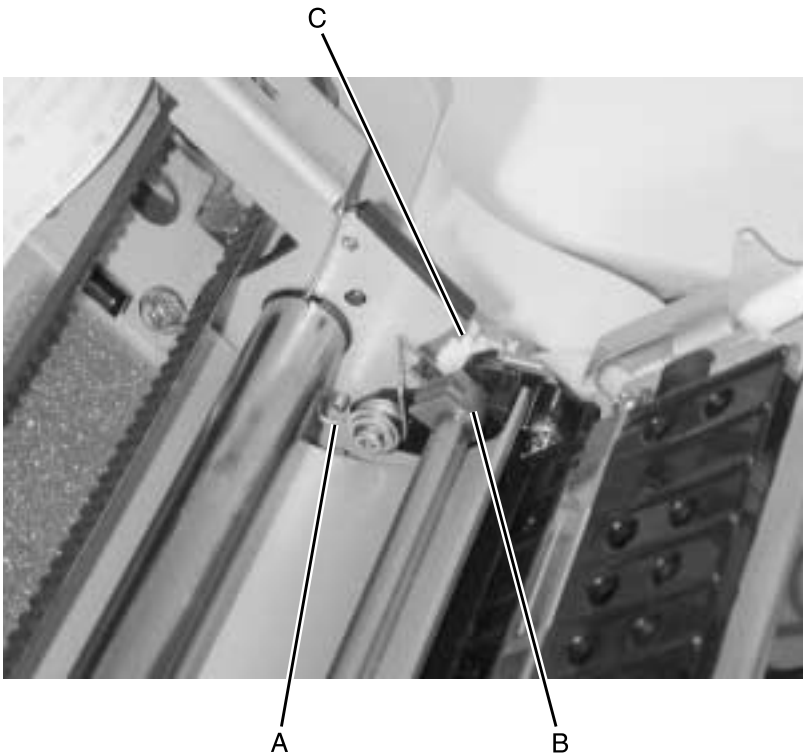

10. Slide the carrier to the center of the printer.
11. Slide the gray slotted spring blocks [B], on each end, toward the center of the roller shaft, taking care that the blocks remain with the shaft during removal.
12. Slide the carrier to the right side of the printer.
13. While holding the lower pinch roller shaft by the gear [C], move the shaft to the left approximately one half inch. Lift the shaft up and to the back of the printer and carefully remove the lower pinch roller and shaft.
14. Be sure to perform the Printhead-to-Platen Gap Adjustment procedure. Go to **“Printhead-to-Platen Gap Adjustment” on page 4-2.**

Roller, Lower Feed Removal

1. Remove the top cover. Go to **“Covers, Top Removal” on page 4-8.**
2. Remove the print unit. Go to **“Print Unit Removal” on page 4-28.**
3. Remove the carrier. Go to **“Carrier Removal” on page 4-16.**
4. Remove the two screws securing the black bracket to the inside of the right side frame.
5. Remove the right side sub frame and the right side gears. Go to **“Right Side Gears, Sub Frame Removal” on page 4-34.**
6. Remove the left side gears. Go to **“Left Side Gears Removal” on page 4-31.**
7. Remove the gears and C-clip from both ends of the lower feed roller.
8. Remove the upper feed roller. Go to **“Roller, Upper Feed Removal” on page 4-36.**

9. Remove the two screws [A] securing the platen to the side frames.

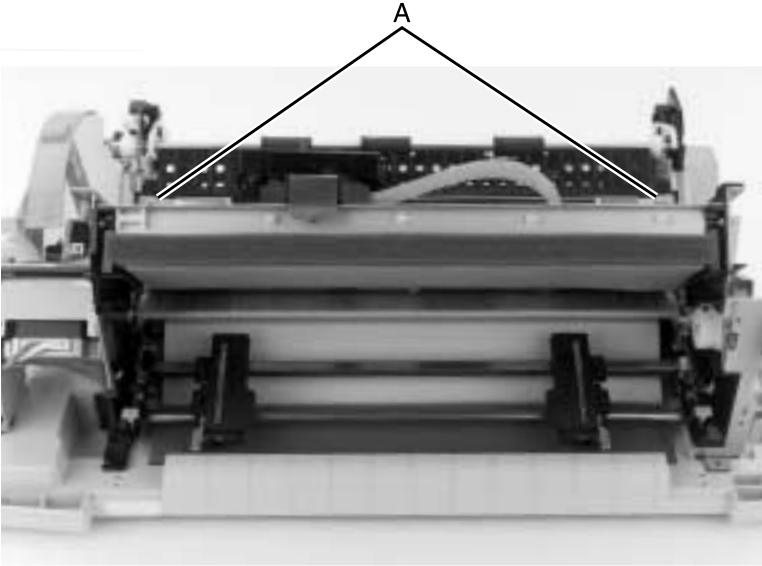

10. Remove the carrier motor bracket. Go to **“Carrier, Motor Assembly Removal” on page 4-21.**
11. Remove the five screws securing the left side frame and remove the frame.
12. Remove the four screws from the right side frame and remove the bottom frame assembly.
13. Remove the five screws from the frame support plate and remove the lower feed roller.
14. Be sure to perform the Printhead-to-Platen Gap Adjustment procedure. Go to **“Printhead-to-Platen Gap Adjustment” on page 4-2.**

Sensors Removals

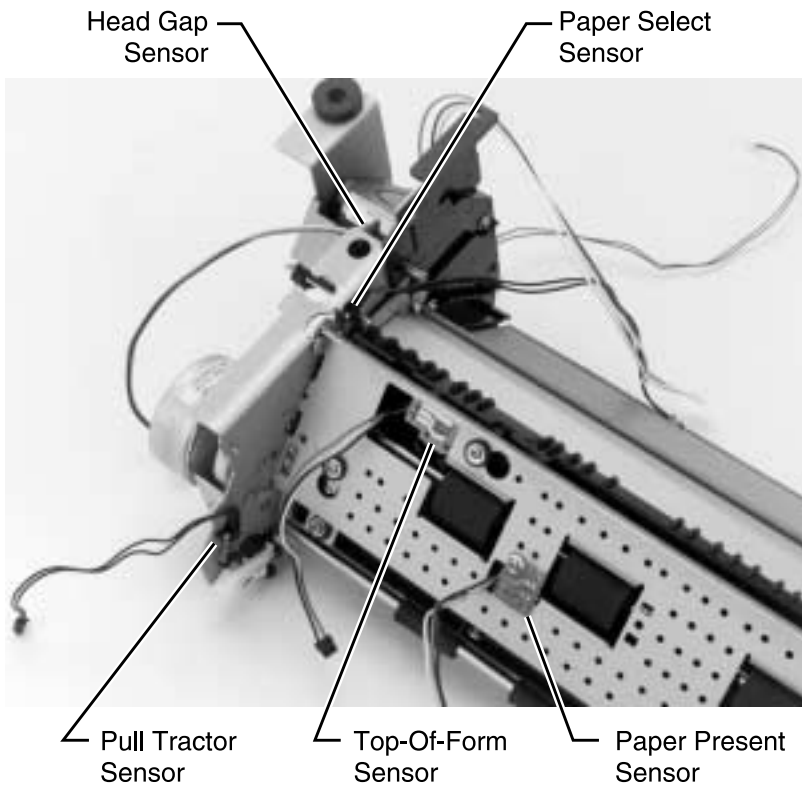

Sensor, Pull Tractor Removal

1. Remove the top cover. Go to **“Covers, Top Removal” on page 4-8.**
2. Remove the small screw securing the pull tractor sensor to the inside of the left frame. Go to **“Sensors Removals” on page 4-43.**
3. Disconnect the pull tractor sensor from the logic board.

Sensor, Head Gap Removal

1. Remove the top cover. Go to **“Covers, Top Removal” on page 4-8.**
2. Remove the screw from the forms thickness lever and remove the lever.
3. Remove the screw from the head gap sensor and remove the sensor.
4. Disconnect the head gap sensor cable from the logic board. Go to **“Sensors Removals” on page 4-43.**

Sensor, Top-Of-Form Removal

1. Remove the top cover. Go to **“Covers, Top Removal” on page 4-8.**
2. Remove the print unit. Go to **“Print Unit Removal” on page 4-28.**
3. Turn the print unit upside down.
4. Unsnap the Top-Of-Form sensor from the platen. Go to **“Sensors Removals” on page 4-43.**

Sensor, Paper Select Removal

1. Remove the top cover. Go to **“Covers, Top Removal” on page 4-8.**
2. Remove the print unit. Go to **“Print Unit Removal” on page 4-28.**
3. Turn the print unit upside down.
4. Remove the 4 small screws securing the paper select sensor to the left side frame. Go to **“Sensors Removals” on page 4-43.**

Sensor, Paper Present Removal

1. Remove the top cover. Go to **“Covers, Top Removal” on page 4-8.**
2. Remove the print unit. Go to **“Print Unit Removal” on page 4-28.**
3. Turn the print unit upside down.
4. Remove the small screw securing the paper present sensor to the bottom frame. Go to **“Sensors Removals” on page 4-43.**

Flags, Paper Present / Top-Of-Form Removal

1. Remove the lower feed roller. Go to **“Roller, Lower Feed Removal” on page 4-41.**
2. Remove the paper present flag, or the top-of-form flag from the paper guide. Go to **“Sensors Removals” on page 4-43.**

Sensor, Home Position Sensor Removal

1. Remove the top cover. Go to **“Covers, Top Removal”** on page 4-8.
2. Disconnect the home position sensor cable from the logic board.
3. Unsnap the home position sensor [A] from the frame.

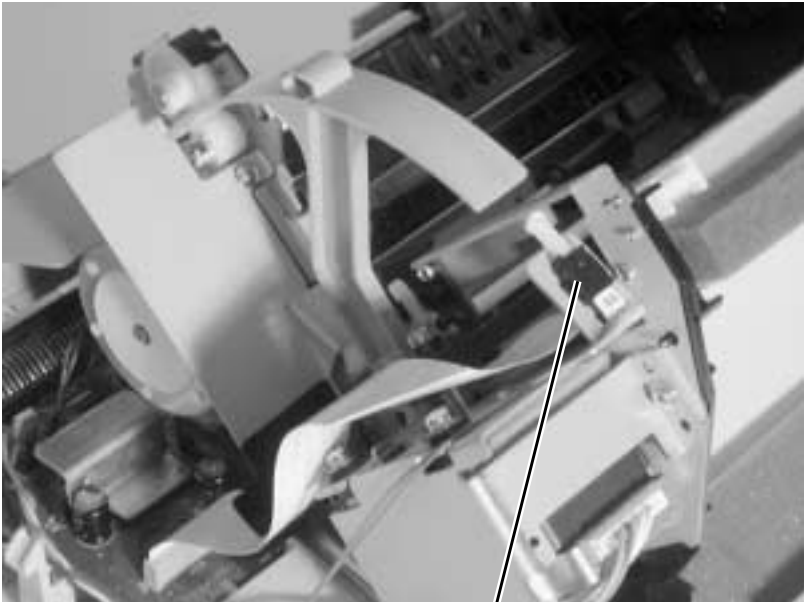

A

Options Removals

Auto Sheet Feeder Gears Removal

1. Remove the right cover.
2. Release the joint gear latch [A] and remove the joint gear.

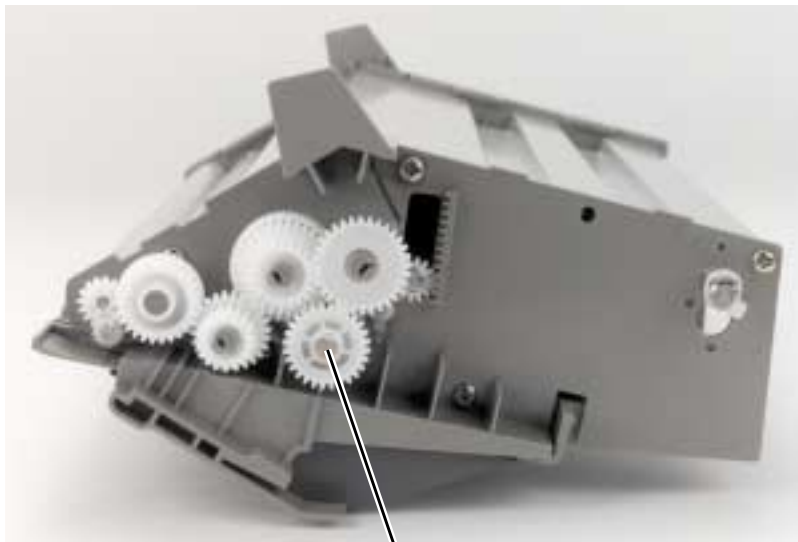

A

3. Release the idler gear latch and remove the idler gear.
4. Release the pick-up gear latch and remove the gear.
5. Release the combination lock mechanism latch.
6. Remove the tension plate on the locker cam and remove the cam.
7. Release the lift gear latch and remove the gear.

Auto Sheet Feeder Pick-up Roller Removal

1. Remove the covers and the cut sheet support.
2. Release the joint gear latch [A] and remove the joint gear, idler gear, and pick-up gear.

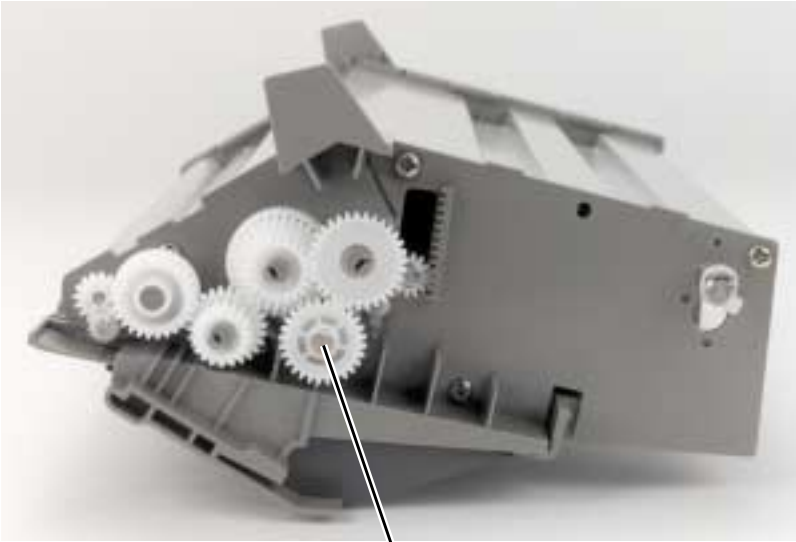

A

3. Remove the left and right roller bushings.
4. Move the pick-up rollers to the ends of the shaft and remove them.

5. Connector Locations

This chapter identifies the locations of specific parts of the printer.

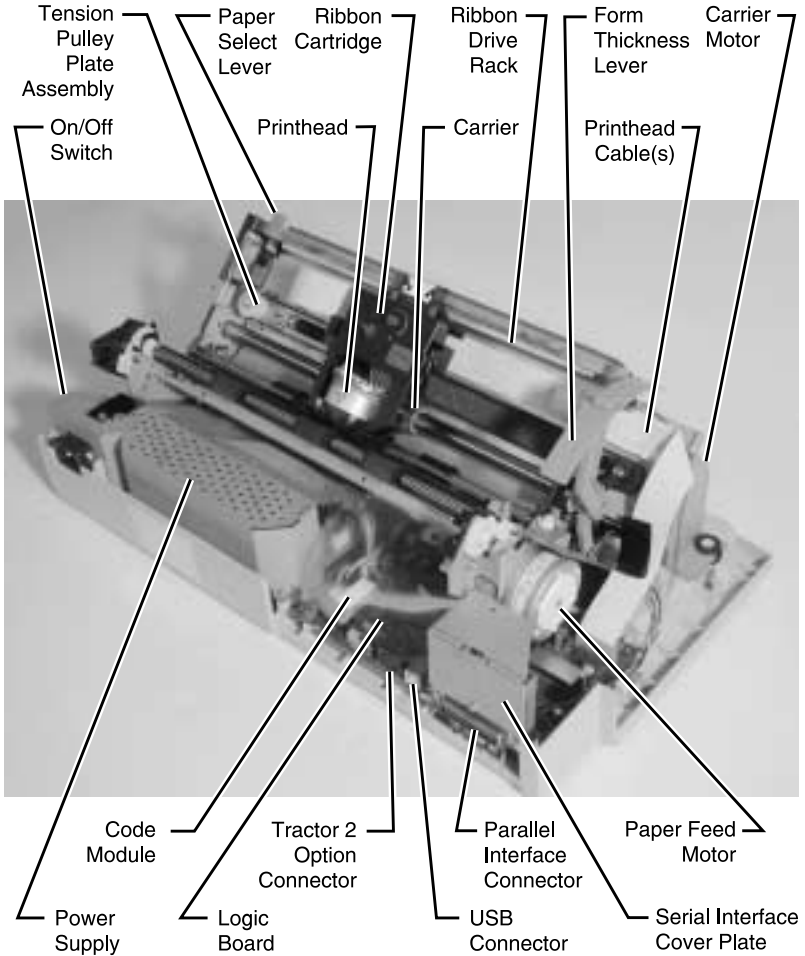

Signal Connections

Power Supply (9w & 24w)

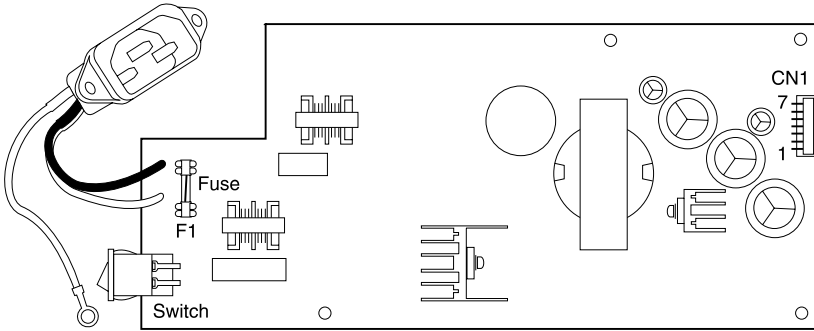

Connector	Pin #	Signal
CN1	1	+40 V dc
	2	+40 V dc
	3	Power Gnd
	4	Power Gnd
	5	Signal Gnd
	6	+5 V dc
	7	Power Save Mode

Connector	Signal
F1	Fuse

Logic Board (9w & 24w)

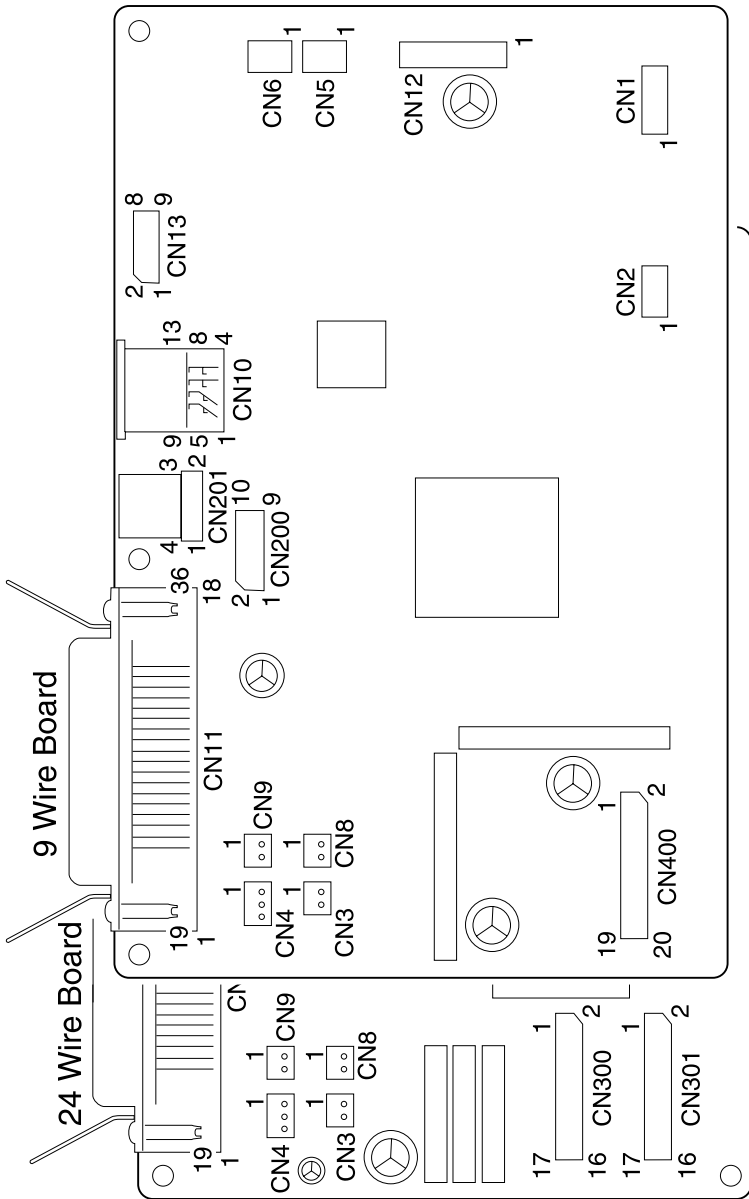

Logic Board - Parallel Interface Cable (9w & 24w)

Connector	Pin #	Signal	Pin #	Signal
CN11	1	-Strobe	19	Signal Gnd
	2	Data 0	20	Signal Gnd
	3	Data 1	21	Signal Gnd
	4	Data 2	22	Signal Gnd
	5	Data 3	23	Signal Gnd
	6	Data 4	24	Signal Gnd
	7	Data 5	25	Signal Gnd
	8	Data 6	26	Signal Gnd
	9	Data 7	27	Signal Gnd
	10	-Acknlg	28	Signal Gnd
	11	Busy	29	Signal Gnd
	12	PE	30	Signal Gnd
	13	Select	31	-INIT
	14	-AUTFED	32	-ERROR
	15	NC	33	Signal Gnd
	16	Signal Gnd	34	NC
	17	Chassis Gnd	35	+5 V dc
	18	+5 V dc	36	-SELIN

Logic Board (9w & 24w)

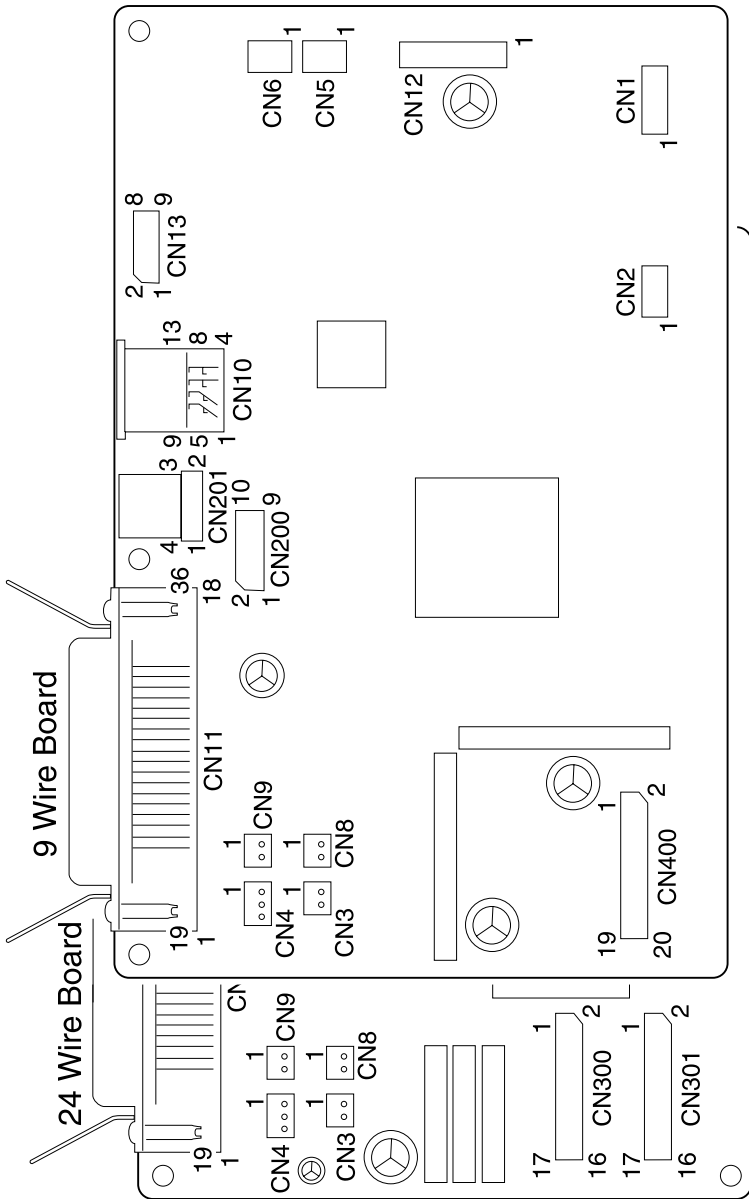

Logic Board - Serial Board (9w & 24w)

Connector	Pin #	Signal
CN200	1	+5 V dc
	2	+5 V dc
	3	-CTS
	4	DTS
	5	RXD
	6	RTS
	7	DSR
	8	TXD
	9	Signal Gnd
	10	SBSET

Connector	Pin #	Signal
CN1	10	+5 V dc
	9	+5 V dc
	8	-CTS
	7	DTS
	6	RXD
	5	RTS
	4	DSR
	3	TXD
	2	Signal Gnd
	1	SBSET

Logic Board (9w & 24w)

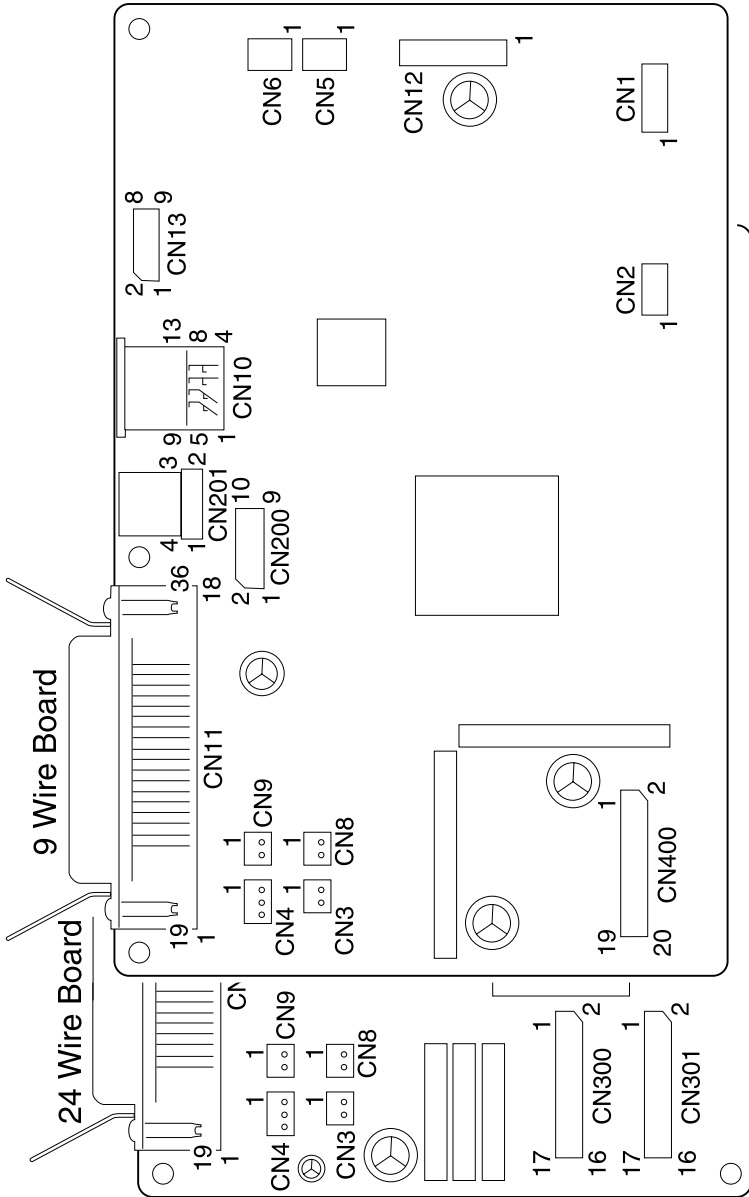

Logic Board - USB Cable (9w & 24w)

Connector	Pin #	Signal
CN201	1	+5 V dc
	2	DMNS
	3	DPLS
	4	Signal Gnd

Logic Board - DC Power (9w & 24w)

Connector	Pin #	Signal
CN12	1	+40 V dc
	2	+40 V dc
	3	Power Gnd
	4	Power Gnd
	5	Signal Gnd
	6	+5 V dc
	7	Power Save Mode

Logic Board - Printhead (9w)

Connector	Pin #	Signal
CN400	1	H4
	2	H6C
	3	H8C
	4	H1C
	5	H6
	6	H2C
	7	H4C
	8	H8
	9	H2
	10	H9
	11	HDTHERMO
	12	+5 V dc
	13	H1
	14	H9C
	15	H3
	16	H7C
	17	H5
	18	H3C
	19	H7
	20	HSC

Logic Board - Printhead (24w)

Connector	Pin #	Signal
CN300	1	+40 V dc
	2	R15
	3	+40 V dc
	4	R21
	5	+40 V dc
	6	R23
	7	+40 V dc
	8	L24
	9	R13
	10	L22
	11	L14
	12	L20
	13	+40 V dc
	14	L18
	15	+40 V dc
	16	L16
	17	+40 V dc

Logic Board (9w & 24w)

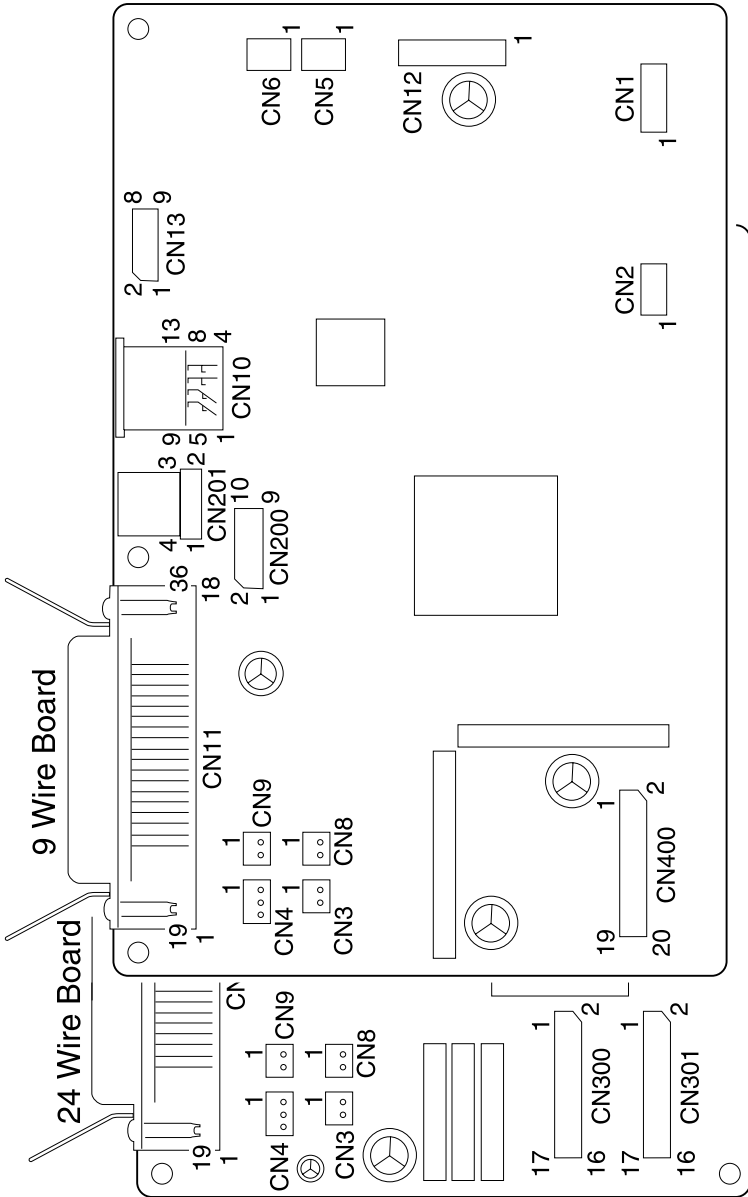

Logic Board - Printhead (24w)

Connector	Pin #	Signal
CN301	1	R9
	2	R11
	3	R7
	4	R17
	5	R5
	6	R19
	7	R3
	8	HDTHERMO
	9	R1
	10	+5 V dc
	11	L2
	12	+40 V dc
	13	L4
	14	+40 V dc
	15	L6
	16	L12
	17	L8
	18	L10

Logic Board (9w & 24w)

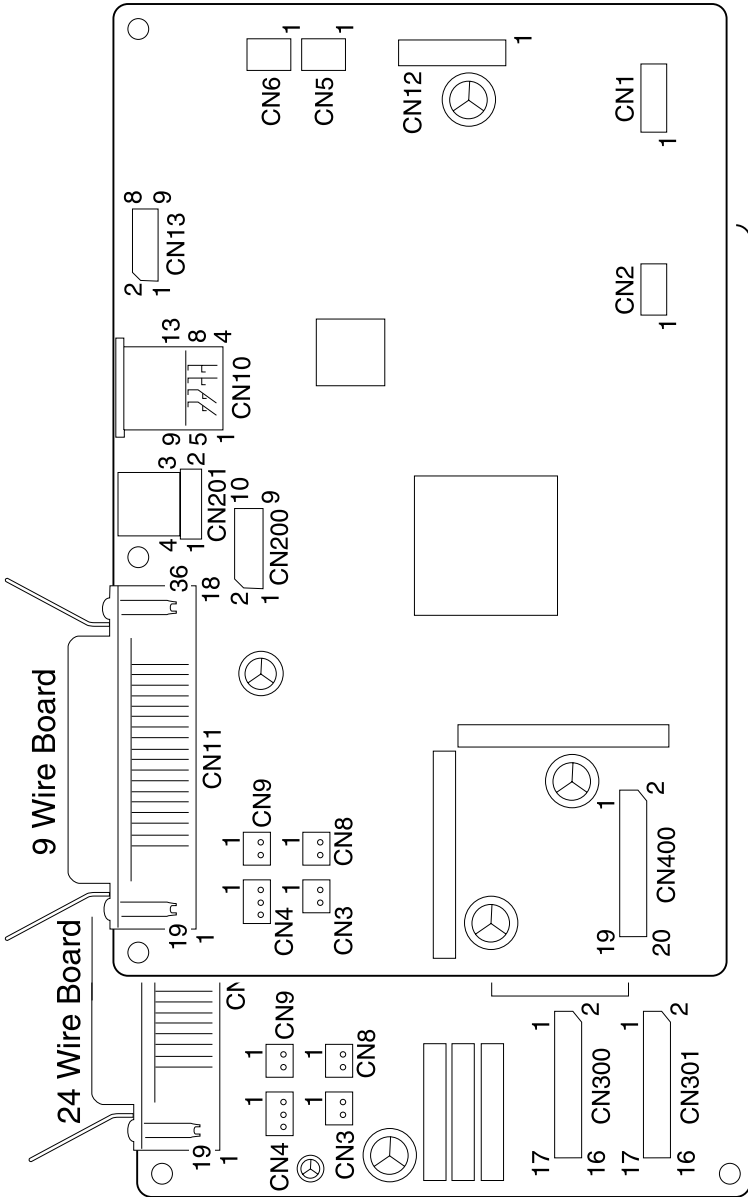

Logic Board - Gap Set Sensor (9w & 24w)

Connector	Pin #	Signal
CN4	1	GAP1
	2	Signal Gnd
	3	GAP2

Logic Board - Home Position Sensor (9w & 24w)

Connector	Pin #	Signal
CN9	1	HPSW
	2	Signal Gnd

Logic Board - Paper Present Sensor (9w & 24w)

Connector	Pin #	Signal
CN5	1	PE1P
	2	PE1
	3	Signal Gnd

Logic Board - Paper Select Sensor (9w & 24w)

Connector	Pin #	Signal
CN8	1	TR/FR
	2	Signal Gnd

Logic Board - Pull Tractor Sensor (9w & 24w)

Connector	Pin #	Signal
CN3	1	PLTR
	2	Signal Gnd

Logic Board - Top Of Form Sensor (9w & 24w)

Connector	Pin #	Signal
CN6	1	Signal Gnd
	2	PE2P
	3	PE2

Logic Board (9w & 24w)

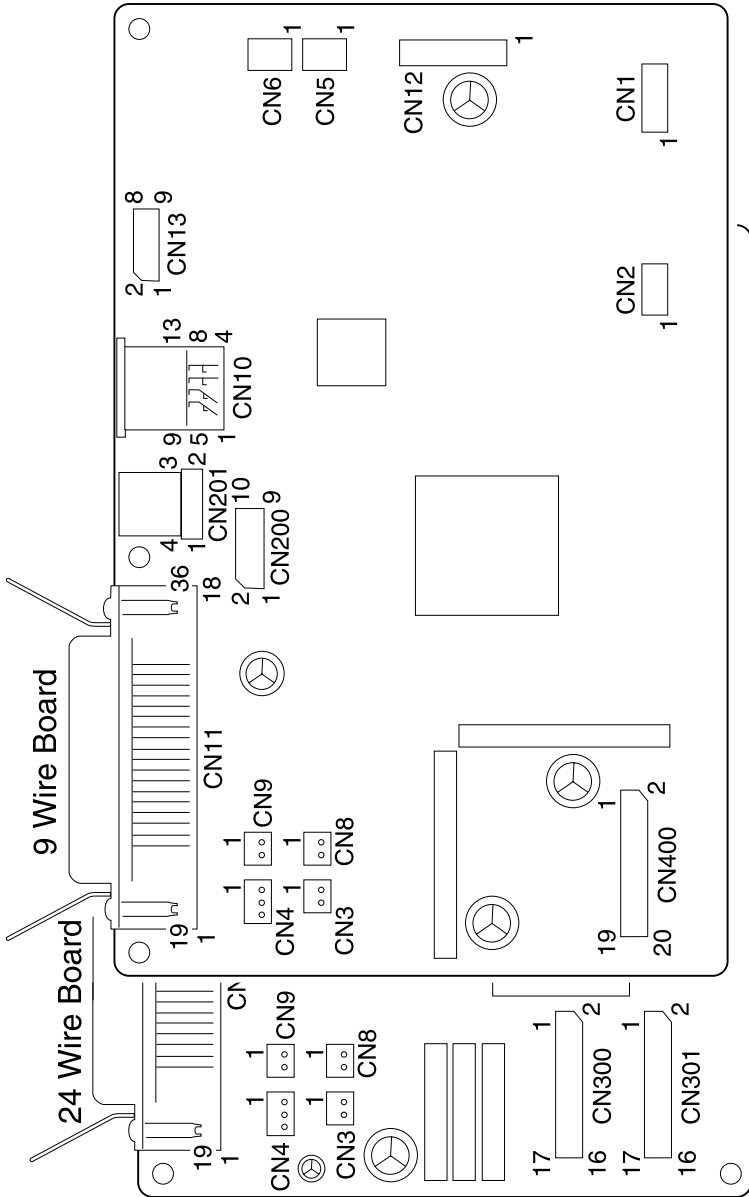

Logic Board - Carrier Motor (9w & 24w)

Connector	Pin #	Signal
CN2	1	CAD
	2	CAC
	3	CAB
	4	CAA

Logic Board - Paper Feed Motor (9w & 24w)

Connector	Pin #	Signal
CN1	1	LFD
	2	LFC
	3	LFB
	4	LFA
	5	NC

Logic Board (9w & 24w)

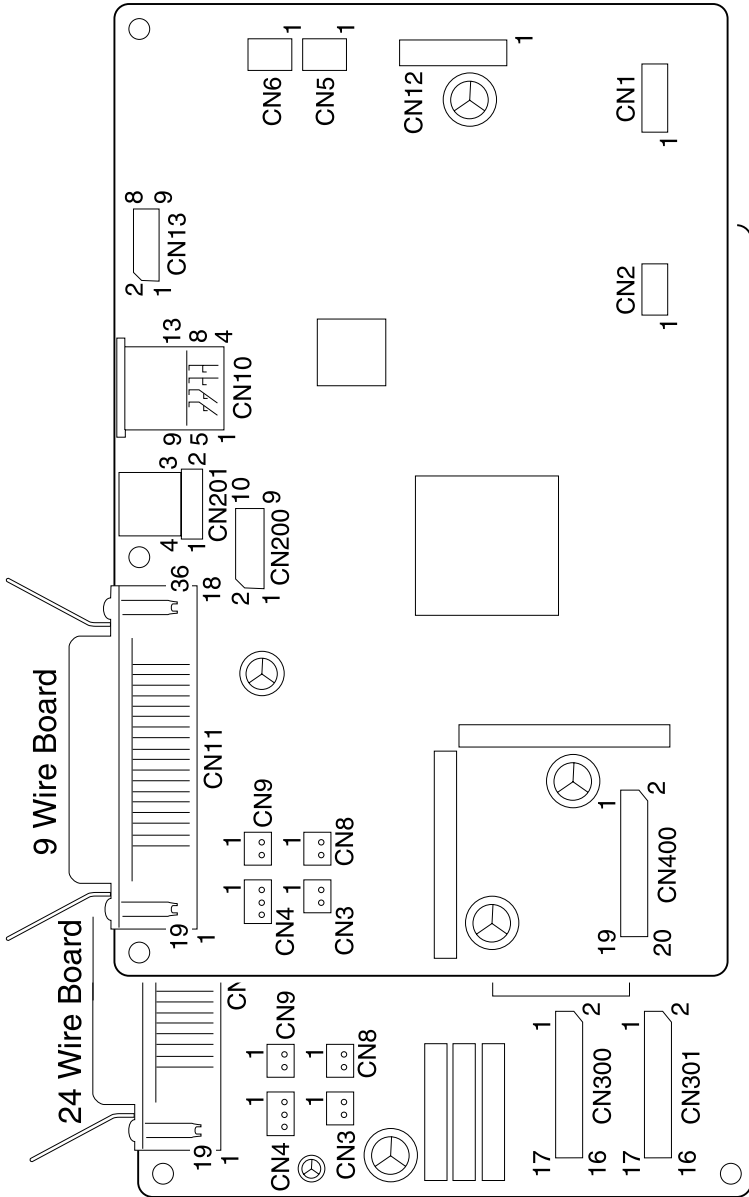

Logic Board - Operator Panel (9w & 24w)

Connector	Pin #	Signal
CN13 Logic Board	1	+5 V dc
	2	SLATCH
	3	+5 V dc
	4	TXD
	5	Signal Gnd
	6	RXD
	7	Signal Gnd
	8	SCLK
	9	SG

Connector	Pin #	Signal
CN1 Operator Panel	1	+5 V dc
	2	SLATCH
	3	+5 V dc
	4	TXD
	5	Signal Gnd
	6	RXD
	7	Signal Gnd
	8	SCLK
	9	SG

Logic Board (9w & 24w)

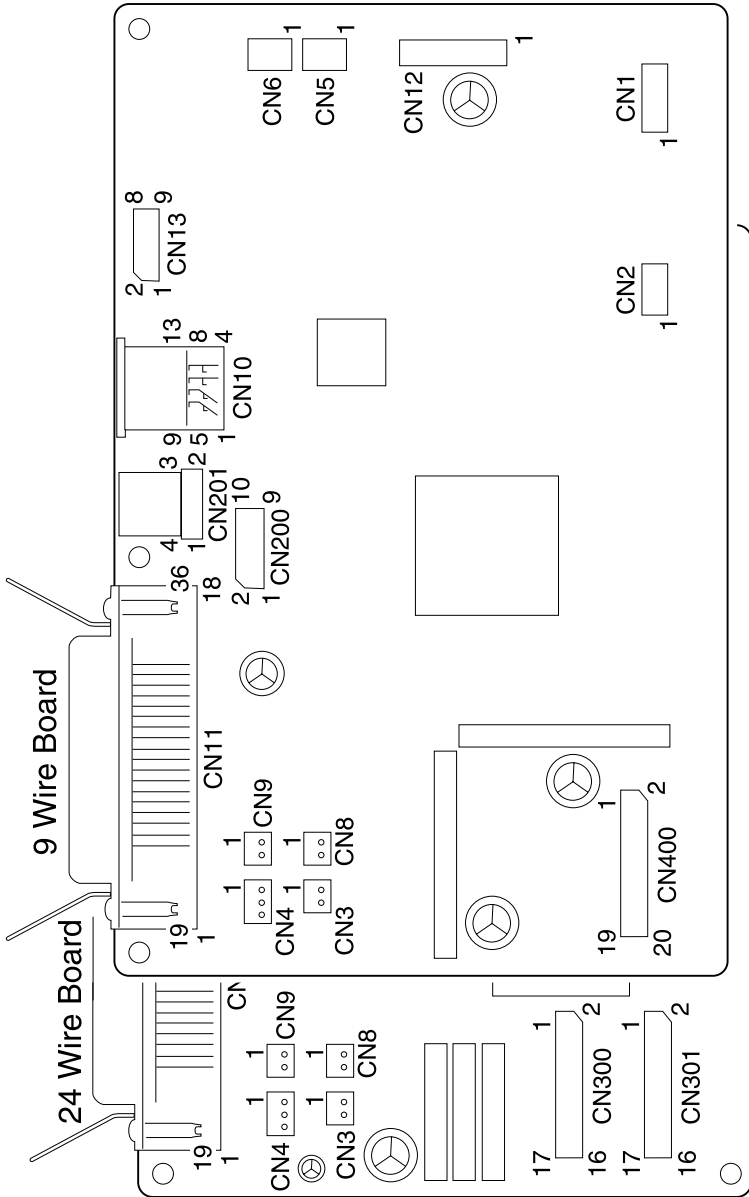

Logic Board - Dual Tractor Cable (9w & 24w)

Connector	Pin #	Signal
CN10	1	+40 V dc
	2	+40 V dc
	3	Power Gnd
	4	Power Gnd
	5	+5 V dc
	6	COCOM
	7	D-SET
	8	Signal Gnd
	9	COA
	10	COB
	11	JAM
	12	D-H.P
	13	D-POS

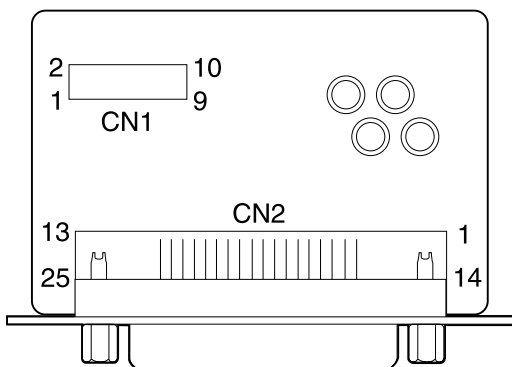
Serial Board - Serial Cable (9w & 24w)

Connector	Pin #	Signal	Pin #	Signal
CN2	1	Chassis Gnd	13	NC
	2	TXD	14	NC
	3	RXD	15	NC
	4	RTS	16	NC
	5	-CTS	17	NC
	6	DSR	18	NC
	7	Signal Gnd	19	NC
	8	NC	20	DTR
	9	NC	21	NC
	10	NC	22	NC
	11	NC	23	NC
	12	NC	24	NC
			25	NC

Tractor 2 Cable Connectors

The Tractor 2 cable is soldered to the Tractor 2 board at CN1; there is no connector.

Connector	Mode
CN1-1	+26 V dc.
CN1-2	+26 V dc.
CN1-3	Frame GND.
CN1-4	Not used.
CN1-5	+5 V dc.
CN1-6	Motor common.
CN1-7	D-Set (signal for Tractor 2 plugged in).
CN1-8	Signal GND.
CN1-9	Motor phase A; 0 V dc except when Tractor 2 motor is on.
CN1-10	Motor phase B; +5 V dc when Tractor 2 not in use; 0 V dc when Tractor 2 is in use.
CN1-11	Not used.
CN1-12	Slider home sensor; +5 V dc when open, 0 V dc when closed.
CN1-13	Tractor 2 in-place sensor; +5 V dc when open, 0 V dc when closed.

6. Preventive Maintenance

This chapter describes procedures for printer preventive maintenance. Following these recommendations can help prevent problems and maintain optimum performance.

Lubrication

Warning: Petroleum-based lubricants can attack polycarbonate parts causing premature failure. Use only mineral oil-based lubricants.

The following parts should be lubricated when replaced:

- Oil felt (carrier block)
- Tractor unit
- Side frame (left)
- Side frame (right)
- Pinch roller (lower)
- Pinch roller spring (left)
- Pinch roller spring (center)
- Pinch roller spring (right)
- Paper separator

Specified Lubricants

- Oil - P/N 1280443
- Approved equivalents:
 - Mobil DTE27
 - Shell Tellus 100
 - Fuchs Renolin MR30
- Grease - P/N 6934659
- Approved equivalent:
 - Mobil 28

Lubrication Points

Oil

- Oil Felt (carrier block)
- Tractor Shaft

Grease

- Side Frame (Left) and Gears
- Side Frame (Right) and ASF Gears
- Pinch Roller, Pinch Roller Springs and Paper Separator
- ASF Side Frames, Gears and Combination Lock Mechanism
- ASF Side Frame (Left) and Upper Feed Roll Shaft
- ASF Pick-up Roller Shaft and Roller Bushings

24xx

Lubrication Points (Oil)

The oil felt [1] in the carrier block.

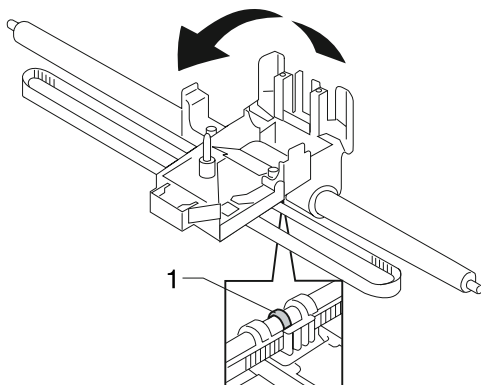

The tractor shaft [1].

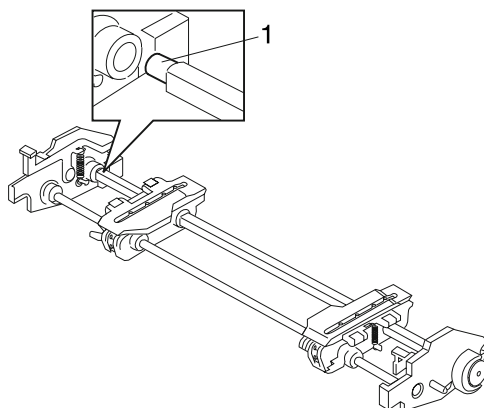

Lubrication Points (Grease)

Gear mounting studs on the right side frame [2].

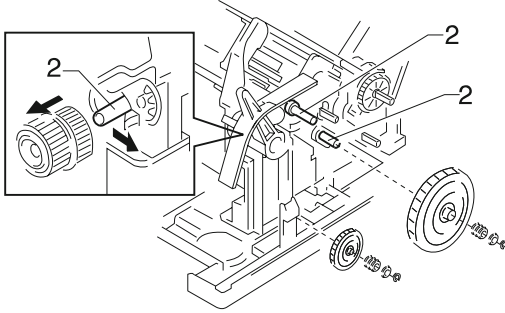

The lower pinch roller [2].

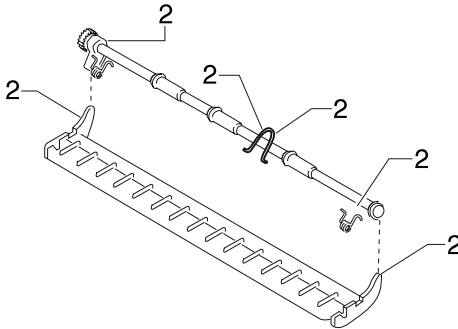

Lubrication Points (Grease) Continued

Gear mounting studs on the left side frame [2].

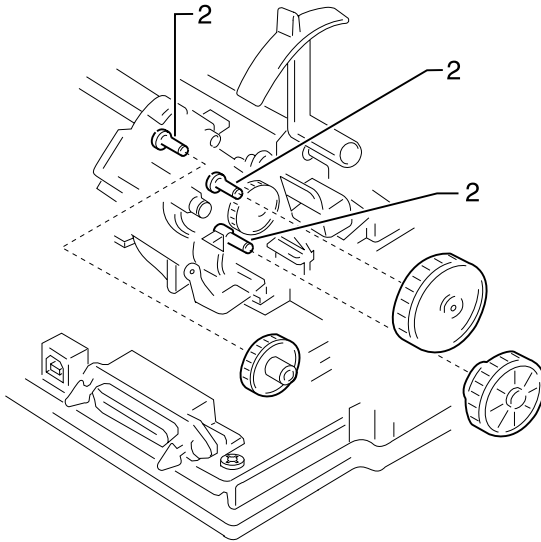

Lubrication Points (Grease) Continued

Gear mounting studs on the left ASF side frame [2].

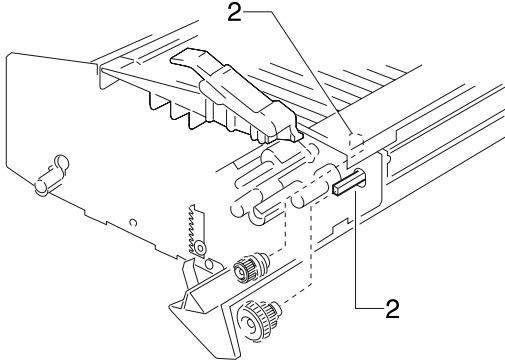

Gear mounting studs on the right ASF side frame [2].

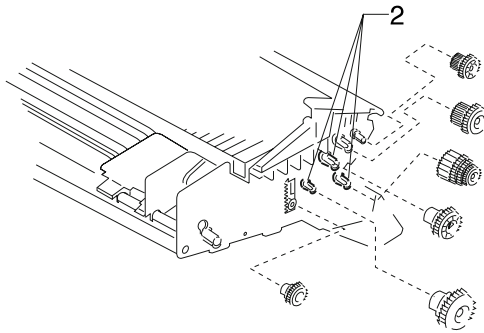

7. Parts Catalog

How To Use This Parts Catalog

SIMILAR ASSEMBLIES: If two assemblies contain a majority of identical parts, they are shown on the same list. Common parts are shown by one index number. Parts peculiar to one or the other of the assemblies are listed separately and identified by description.

NS: (Not Shown) in the Asm-Index column indicates that the part is procurable but is not pictured in the illustration.

Note: Graphic artwork depicting FRU assemblies is designed using the 2480-100 (9-wire) model, as reference. Some of the artwork may not be completely representative of all models. For example, the 24-wire models are not depicted with two printhead cables and there is no artwork depicting the extended carriage models 2481 or 2491.

Assembly 1: Covers

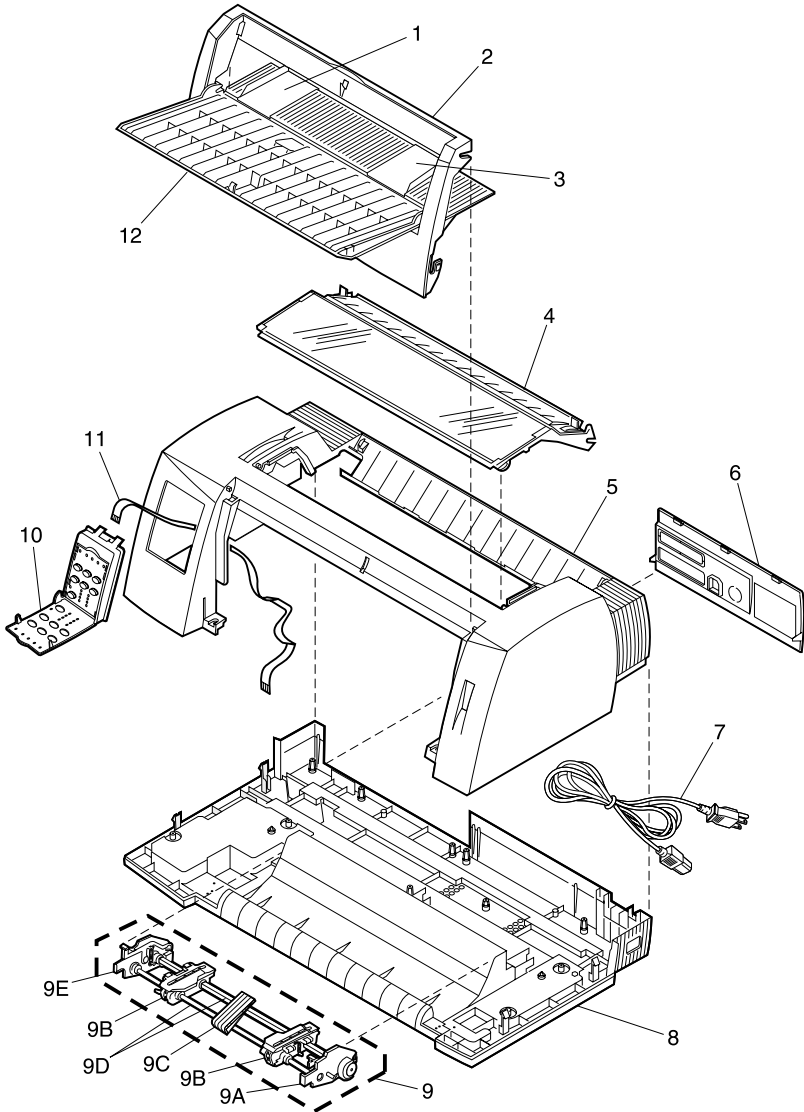

Asm-Index	Part Number	Description
1 - 1	12G3877	Guide, Left Paper
2	12G3873	Cover, Front Unit (2480, 2490)
2	12G3874	Cover, Front Unit (2481, 2491)
3	12G3878	Guide, Right Paper
4	12G3858	Cover, Ribbon Access Unit (2480)
4	12G3859	Cover, Ribbon Access Unit (2481)
4	12G3868	Cover, Ribbon Access Unit (2490)
4	12G3869	Cover, Ribbon Access Cover (2491)
5	12G3871	Cover, Top (2480, 2490)
5	12G3872	Cover, Top (2481, 2491)
6	12G3870	Cover, Option
7	79F4757	Line Cord: U.S., AFE (LV), Canada, Central and South America, Mexico, Saudi Arabia (LV)
7	1339519	Line Cord: Malaysia, and Singapore, United Kingdom
7	1339520	Line Cord: Austria, Belgium, Brazil, Germany, Greece, Finland, France, Indonesia, Luxembourg, Portugal, Norway, Saudi Arabia (HV), Spain, Sweden, The Netherlands, Turkey
7	1339525	Line Cord - Denmark
7	1339524	Line Cord - Chile, Italy
7	1339521	Line Cord - Israel
7	1339523	Line Cord - South Africa
7	1339522	Line Cord - Switzerland
7	1339518	Line Cord: Argentina, Australia, New Zealand, Paraguay
7	1339517	Line Cord - Peru

Assembly 1: Covers

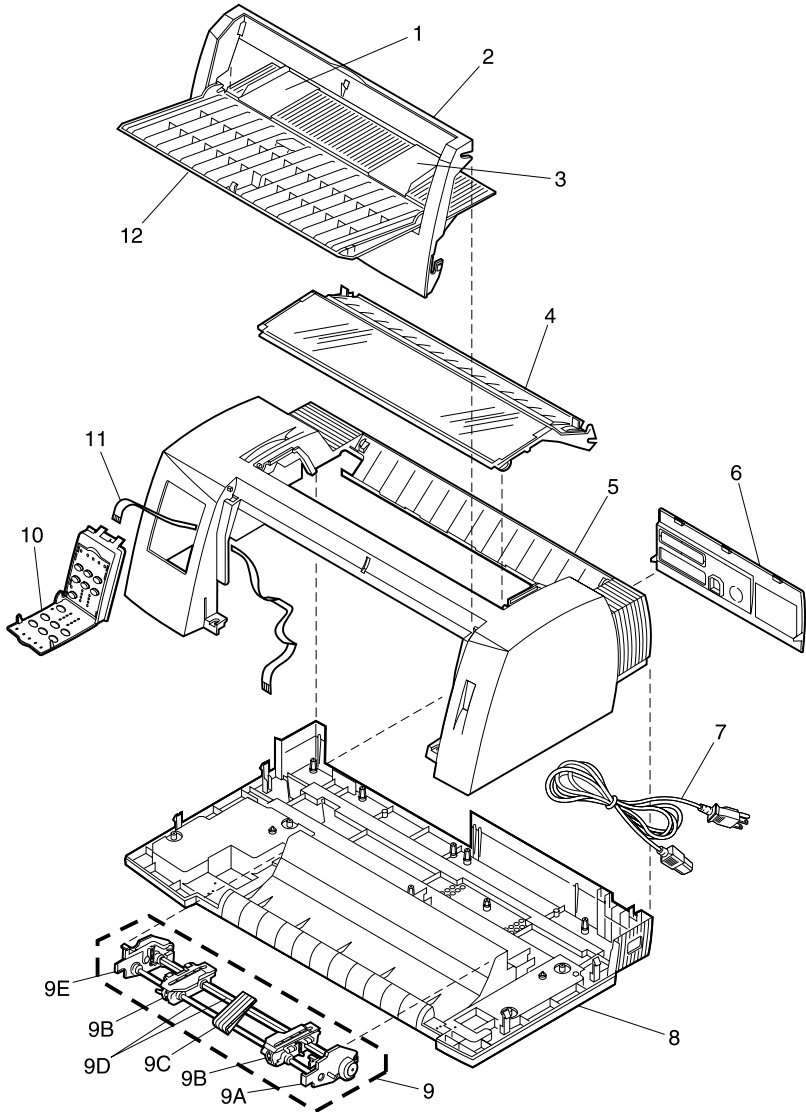

Asm-Index	Part Number	Description
1 - 8	12G3856	Cover, Bottom (2480, 2490)
8	12G3857	Cover, Bottom (2481, 2491)
9	12G3854	Tractor Unit (2480, 2490)
9	12G3855	Tractor Unit (2481, 2491)
9A	12G3850	Frame, Right Side Tractor
9B	12G3853	Tractors, Left and Right
9C	79F4830	Support, Tractor Paper
9D	12G3851	Shaft Set, Tractor (2480, 2490)
9D	12G3852	Shaft Set, Tractor (2481, 2491)
9E	12G3849	Frame, Left Side Tractor
10	12G3810	Operator Panel Assembly (248X)
10	12G3811	Operator Panel Assembly (249X)
11	12G3883	Cable, Operator Panel
12	12G3875	Cover, Front Guide (2480, 2490)
12	12G3876	Cover, Front Guide (2481, 2491)
NS	12G3999	Cover, Operator Panel Front w/ Overlay Packs
NS	12G3881	Overlay Pack, Operator Panel (248X)
NS	12G3882	Overlay Pack, Operator Panel (249X)
NS	12G3939	Stand, Paper

Assembly 2: Carrier / Paper Feed Right Side

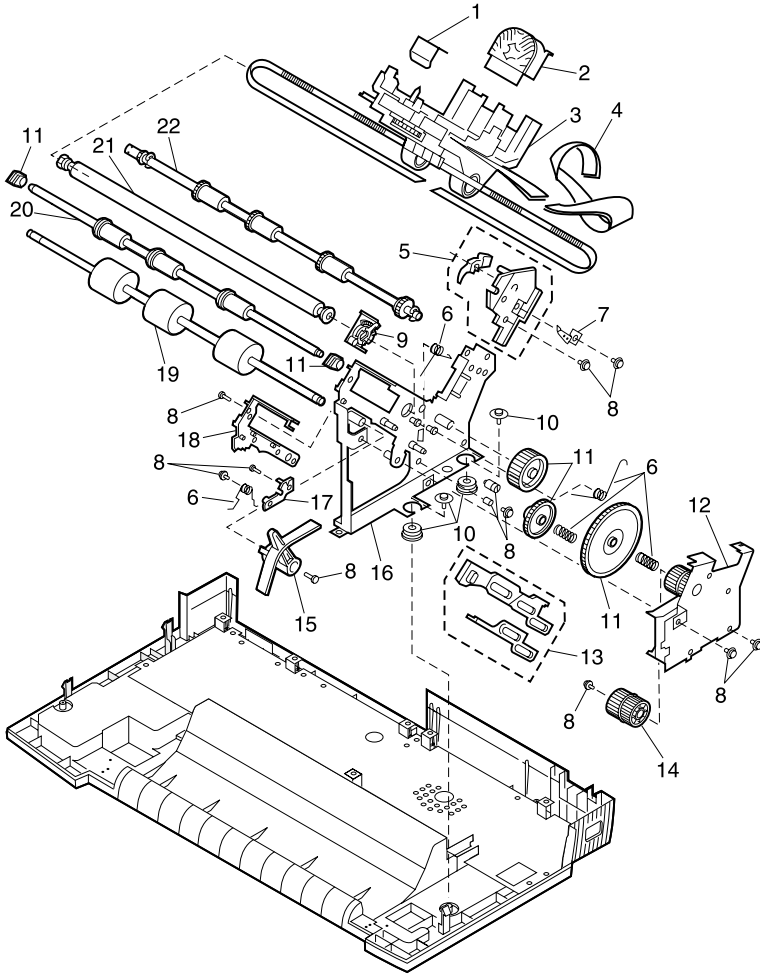

Asm-Index	Part Number	Description
2 - 1	12G3841	Carrier Roller Set
2	12G3894	Printhead Assembly (2480, 2481)
2	12G3895	Printhead Assembly (2490, 2491)
3	12G3838	Carrier Unit (2480)
3	12G3837	Carrier Unit (2481)
3	12G3840	Carrier Unit (2490)
3	12G3839	Carrier Unit (2491)
4	12G3889	Cable, Printhead (2480)
4	12G3888	Cable, Printhead (2481)
4	12G3891	Cable, Printhead (2490)
4	12G3890	Cable, Printhead (2491)
5	12G3942	Kit, Pull Tractor Actuator
6	12G3896	Springs, Parts Packet
7	12G3836	Kit, ESD Ground (2490, 2491)
7	12G3887	Kit, ESD Ground (2480, 2481)
8	12G3907	Screws, Washers and Clips, Parts Packet
9	12G3931	Kit, Head Gap Adjustment
10	12G3884	Damper, Frame Assembly
11	12G3905	Gears and Bushings, Parts Packet (248X)
11	12G3906	Gears and Bushings, Parts Packet (249X)
12	12G3834	Sub Frame, Right Side
13	12G3898	Cam, Release Slider and Sub Slider
14	11A3274	Gear, Idler (2480, 2481)
14	11A3275	Gear, Idler (2490, 2491)
15	12G3897	Lever, Paper Select Lever
16	12G3819	Frame, Right Side
17	12G3932	Holder, Lower Pinch Roller Shaft, Right
18	12G3949	Guide, ASF/DTR, Right
19	12G3823	Roller, Lower Feed (2480, 2490)
19	12G3822	Roller, Lower Feed (2481, 2491)
20	12G3835	Roller, Lower Pinch (2480, 2490)
20	12G3943	Roller, Lower Pinch (2481, 2491)
21	12G3900	Shaft, Carrier (2480, 2490)
21	12G3901	Shaft, Carrier (2481, 2491)

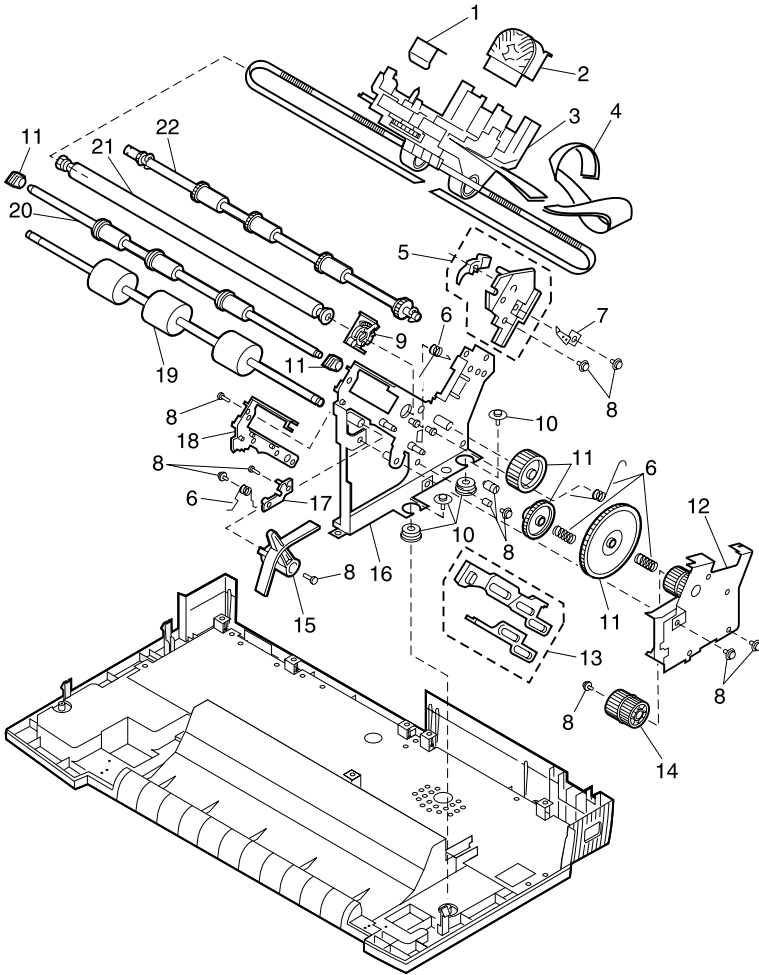
Assembly 2: Carrier / Paper Feed Right Side

24xx

Asm-Index	Part Number	Description
2 - 22	12G3832	Roller, Upper Feed (2480, 2490)
22	12G3833	Roller, Upper Feed (2481, 2491)

Assembly 3: Carrier / Paper Feed Left Side

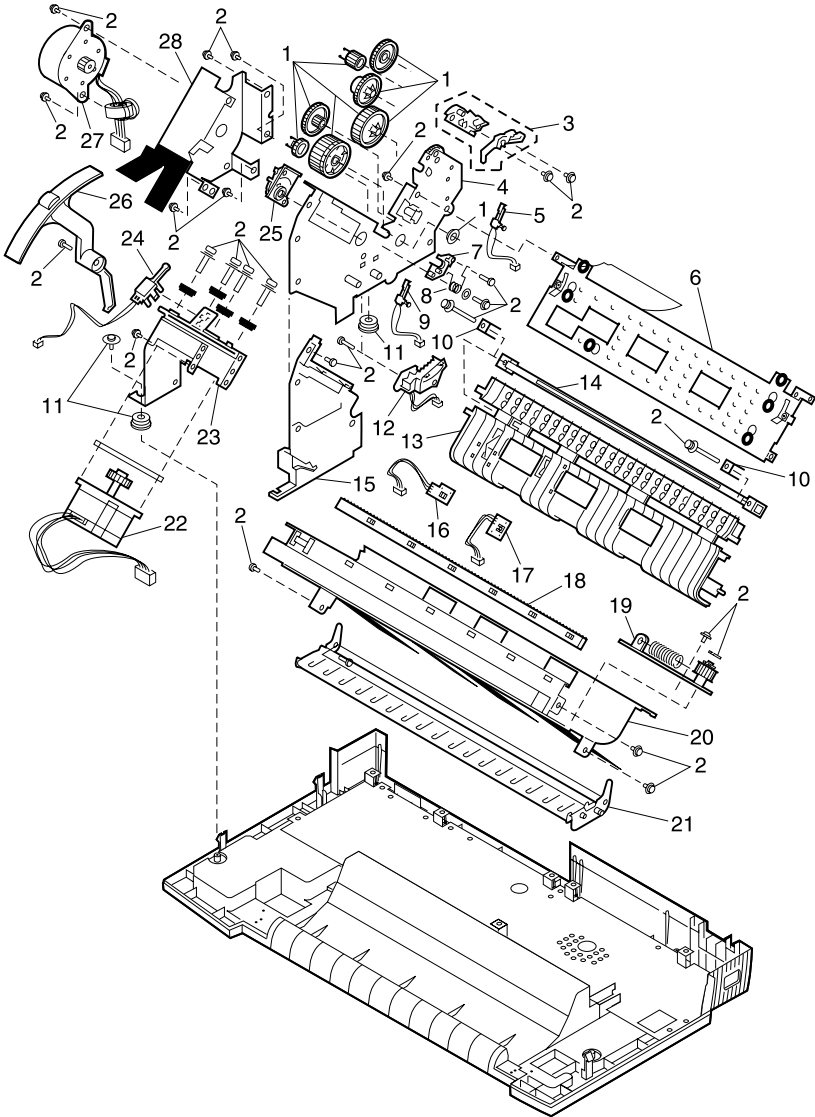

Asm-Index	Part Number	Description
3 - 1	12G3905	Gears and Bushings, Parts Packet (248X)
1	12G3906	Gears and Bushings, Parts Packet (249X)
2	12G3907	Screws, Washers and Clips, Parts Packet
3	12G3942	Kit, Pull Tractor Actuator
4	12G3817	Frame, Left Side (2480, 2481)
4	12G3818	Frame, Left Side (2490, 2491)
5	12G3940	Sensor, Pull Tractor
6	12G3922	Plate, Frame Support (2480, 2490)
6	12G3844	Plate, Frame Support (2481, 2491)
7	12G3935	Holder, Lower Pinch Roller Shaft, Left
8	12G3896	Springs, Parts Packet
9	12G3941	Sensor, Paper Select
10	12G3902	Holder, Platen
11	12G3884	Damper, Frame Assembly
12	12G3946	Sensor, Head Gap
13	12G3821	Guide, Paper Assembly (2480, 2490)
13	12G3820	Guide, Paper Assembly (2481, 2491)
14	12G3826	Platen (2480, 2490)
14	12G3825	Platen (2481, 2491)
15	12G3948	Guide, ASF/DTR, Left
16	12G3909	Top-Of-Form Sensor
17	12G3824	Sensor, Paper Present
18	79F4802	Gear, Ribbon Drive Rack (2480, 2490)
18	79F4834	Gear, Ribbon Drive Rack (2481, 2491)
19	12G3831	Plate, Tension Pulley Assembly
20	12G3937	Plate, Carrier Assembly (2480, 2490)
20	12G3938	Plate, Carrier Assembly (2481, 2491)
21	12G3828	Separator, Paper (2480, 2490)
21	12G3827	Separator, Paper (2481, 2491)
22	12G3846	Motor, Carrier
23	12G3892	Bracket, Carrier Motor
24	12G3845	Sensor, Home Position

Assembly 3: Carrier / Paper Feed Left Side

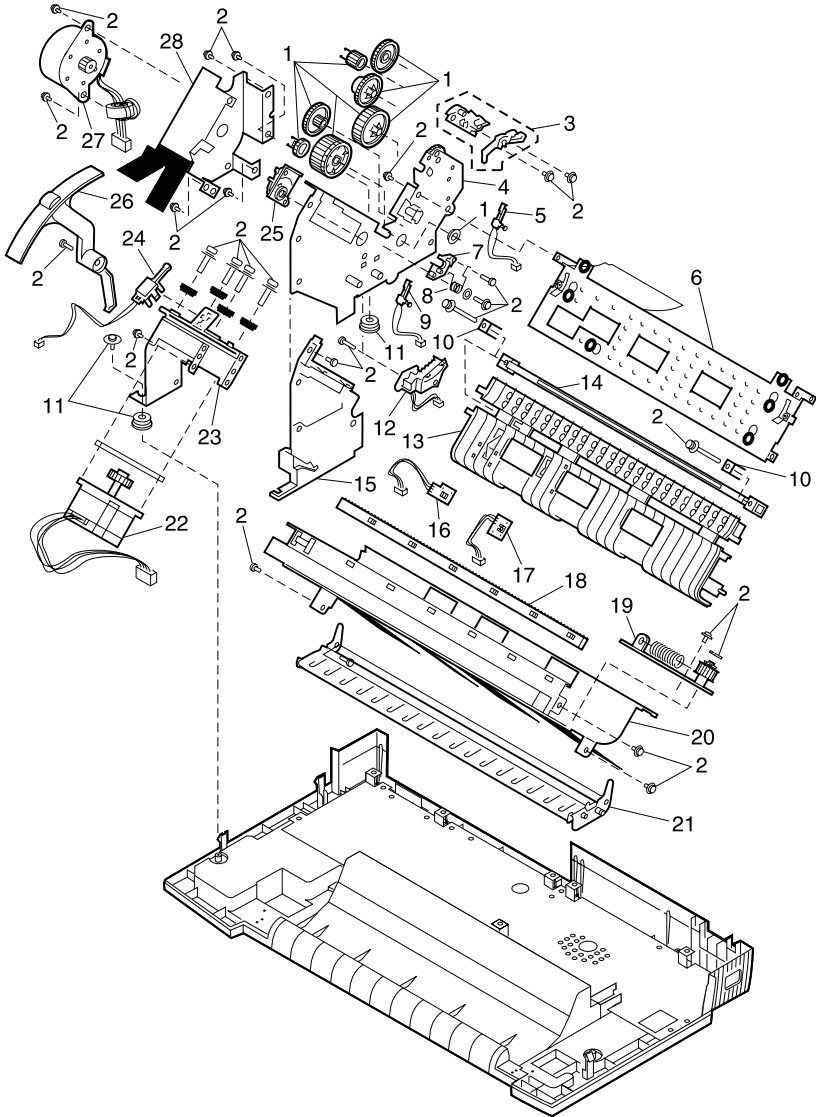

Asm-Index	Part Number	Description
3 - 25	12G3931	Kit, Head Gap Adjustment
26	12G3947	Lever, Form Thickness
27	12G3842	Motor, Paper Feed
28	12G3843	Bracket, Paper Feed Motor Assembly

Assembly 4: Electronics

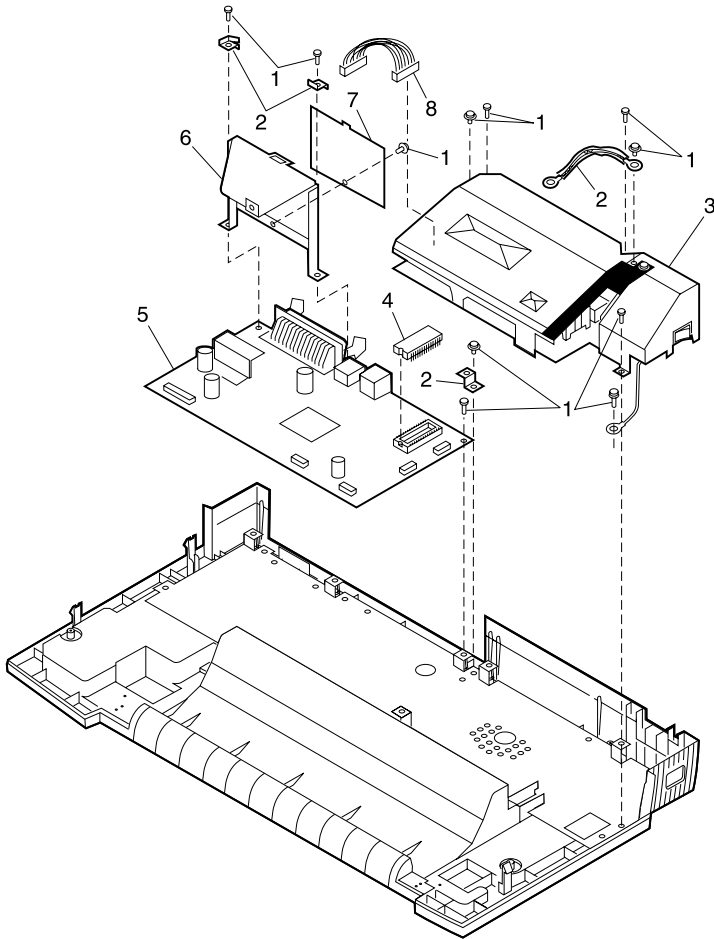

Asm-Index	Part Number	Description
4 - 1	12G3907	Screws, Washers and Clips, Parts Packet
2	12G3836	Kit, ESD Ground (2490, 2491)
2	12G3887	Kit, ESD Ground (2480, 2481)
3	12G3801	Power Supply Unit, LV
3	12G3800	Power Supply Unit, HV
4	12G3812	Module, EPROM (248X)
4	12G3813	Module, EPROM (249X)
4	12G3848	Module, EPROM (Okidata MICROLINE)
5	12G3802	Board, Logic W/O EPROM (2480 LV)
5	12G3806	Board, Logic W/O EPROM (2480 HV)
5	12G3803	Board, Logic W/O EPROM (2481 LV)
5	12G3807	Board, Logic W/O EPROM (2481 HV)
5	12G3804	Board, Logic W/O EPROM (2490 LV)
5	12G3808	Board, Logic W/O EPROM (2490 HV)
5	12G3805	Board, Logic W/O EPROM (2491 LV)
5	12G3809	Board, Logic W/O EPROM (2491 HV)
6	12G3886	Bracket, Serial Interface Card
7	12G3885	Plate, Serial Interface Card
8	12G3861	Cable, Power Supply (2480, 2490)
8	12G3860	Cable, Power Supply (2481, 2491)
NS	12G3903	Kit, Fuse (LV)
NS	12G3904	Kit, Fuse (HV)
NS	12G3929	Card, Serial Interface Card with Plate
NS	12G3936	Cable, Serial Interface Cable

Assembly 5: ASF - Roller / Support

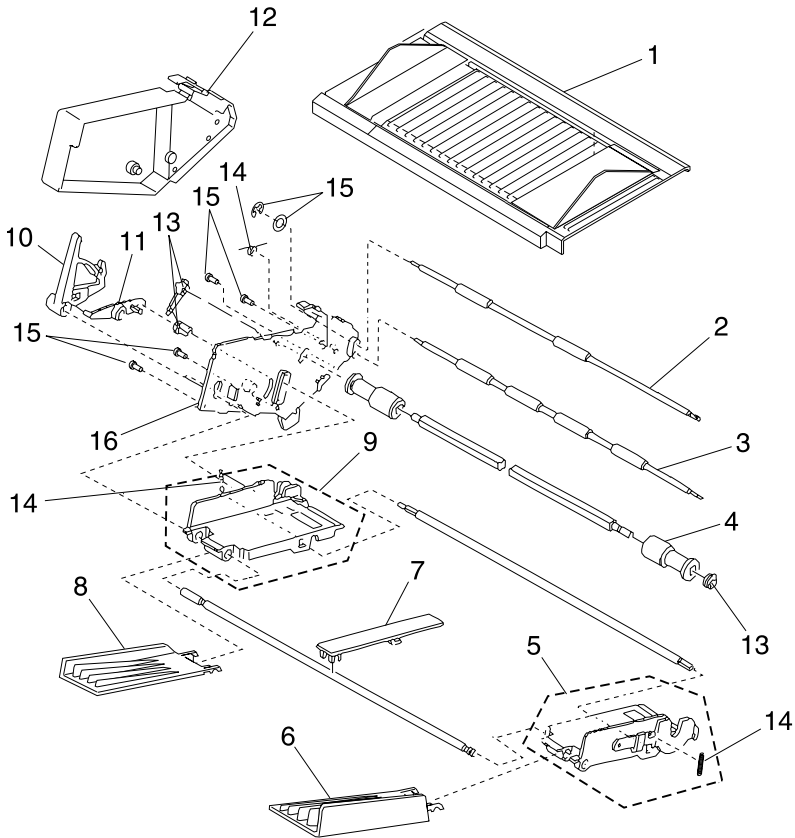

Asm-Index	Part Number	Description
5 - 1	12G3814	Support, ASF Cut Sheet W/ Guides (2480, 2490)
1	12G3908	Support, ASF Cut Sheet W/ Guides (2481, 2491)
2	95F6886	Roller, ASF Upper Feed (2480, 2490)
2	95F6896	Roller, ASF Upper Feed (2481, 2491)
3	95F6887	Roller, ASF Lower Feed (2480, 2490)
3	95F6897	Roller, ASF Lower Feed (2481, 2491)
4	95F6885	Roller, ASF Pick-up Left and Right (2480, 2490)
4	1333275	Roller, ASF Pick-up Left and Right (2481, 2491)
5	12G3911	Hopper, ASF Right (2480, 2490)
5	12G3893	Hopper, ASF Right (2481, 2491)
6	12G3912	Support, ASF Paper Right
7	12G3914	Support, ASF Paper Center (2481, 2491)
8	12G3915	Support, ASF Paper Left
9	12G3916	Hopper, ASF Left
10	12G3933	Lever, ASF Paper Load
11	12G3934	Link, ASF Paper Load
12	12G3918	Cover, ASF Left
13	95F6892	ASF Gears and Bushings, Parts Packet
14	95F6893	ASF Springs, Parts Packet
15	95F6894	ASF Screws, Parts Packet
16	12G3944	Frame, ASF Side Left

Assembly 6: ASF - Side Frame / Covers

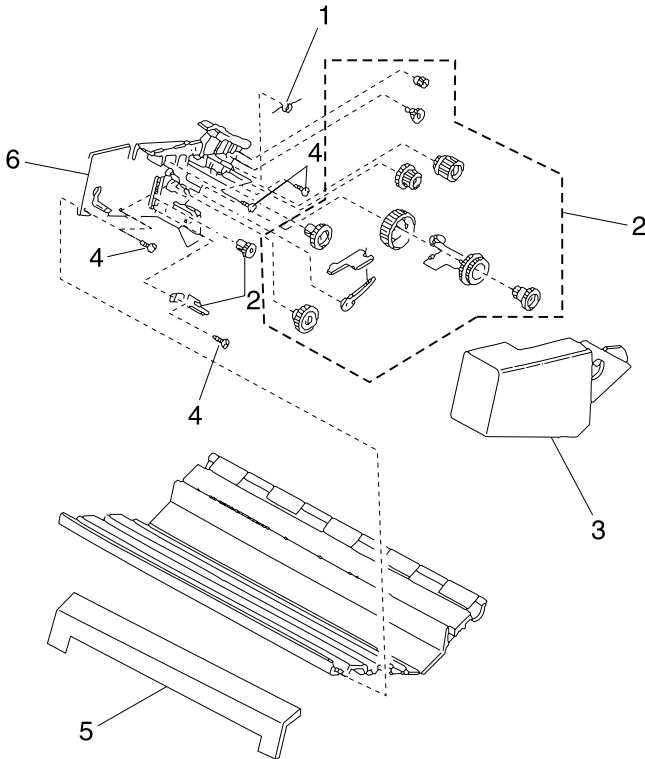

Asm-Index	Part Number	Description
6 -1	95F6893	ASF Springs, Parts Packet
2	95F6892	ASF Gears and Bushings, Parts Packet
3	12G3920	Cover, ASF Right
4	95F6894	ASF Screws, Parts Packet
5	12G3921	Cover, ASF/TR2 Front (2480, 2490)
5	12G3930	Cover, ASF/TR2 Front (2481, 2491)
6	12G3945	Frame, ASF Side Right
NS	12G3939	Stand, Paper

Assembly 7: Tractor 2 Option

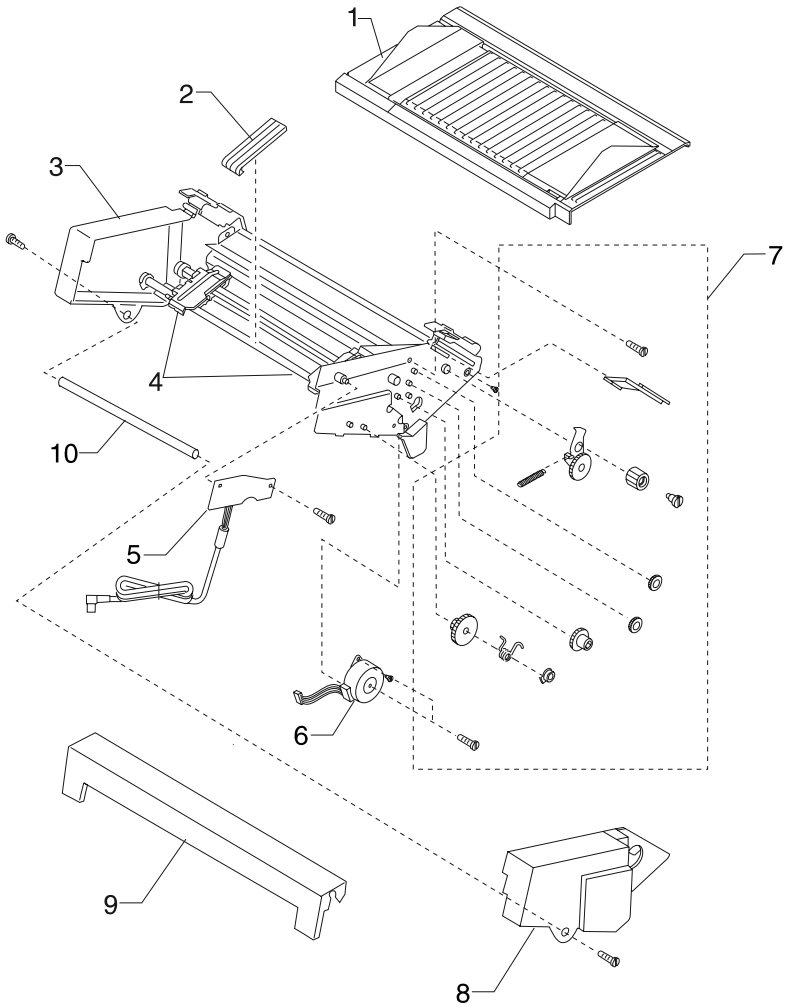

Asm-Index	Part Number	Description
7 - 1	12G3923	Table, Tractor 2 Paper W/ Guides (2480, 2490)
1	12G3924	Table, Tractor 2 Paper W/ Guides (2481, 2491)
2	11A3338	Guide, Tractor 2 Paper
3	12G3926	Tractor and Frame Assembly, Tractor 2 (2480, 2490)
3	12G3927	Tractor and Frame Assembly, Tractor 2 (2481, 2491)
4	12G3853	Kit, Tractors Left and Right
5	11A3335	Board Assembly W/Cable and Ferrite, Tractor 2 (2480, 2490)
5	11A3336	Board Assembly W/Cable and Ferrite, Tractor 2 (2481, 2491)
6	11A3337	Motor, Tractor 2
7	11A3341	Parts Packet, Tractor 2
8	12G3928	Cover, Tractor 2, Right
9	12G3921	Cover, ASF/Tractor 2, Front (2480, 2490)
9	12G3930	Cover, ASF/Tractor 2, Front (2481, 2491)
10	11A3283	Shaft, Tractor 2 Support (2480, 2490)
10	11A3284	Shaft, Tractor 2 Support (2481, 2491)

Coax / Twinax Adapter

Asm-Index	Part Number	Description
NS	12G3704	Adapter, Coax (Power Cable and Adapter)
NS	12G3705	Adapter, Twinax (Power Cable and Adapter)
NS	12G3709	Bracket, Adapter (Bracket Only)
NS	13A0297	Cable, Coax (Cable Only)
NS	13A0296	Cable, Twinax (Cable Only)
NS	11A6109	Cable, Socket Power Coax, Twinax (Socket Power Cable Only)

Index

A

- Abbreviations 1-6
- Adjustments 4-2
 - Bidirectional Print 4-4
 - Printhead-to-Platen Gap 4-2
- ASF
 - Principles of Operation 2-14

C

- Connections
 - Logic Board
 - Carrier Motor 5-20
 - DC Power 5-8
 - Dual Tractor Cable 5-24
 - Gap Set Sensor 5-16
 - Home Position Sensor 5-16
 - Operator Panel 5-22
 - Paper Feed Motor 5-20
 - Paper Present Sensor 5-16
 - Paper Select Sensor 5-18
 - Parallel Interface Cable 5-4
 - Printhead (24w) 5-12
 - Printhead (9w) 5-10
 - Pull Tractor Sensor 5-18
 - Serial Board 5-6
 - Top of Form Sensor 5-18
 - USB Cable 5-8
 - Power Supply 5-2
 - Serial Board
 - Serial Cable 5-25
 - Tractor 2 5-26
- Connector Locations 5-1

D

- Defaults
 - U.S. 3-5
 - World Trade 3-5
- Diagnostic Aids 3-1
- Diagnostic Information 2-1

E

- Entering Setup Mode 1-2

- Error Codes 2-2
- Error Indication Table 2-2
- ESD-sensitive parts 4-1
- Exiting Setup Mode 1-2

G

- General Information 1-1

H

- Hex Trace Mode 3-4

I

- Interface Menu Options 1-3
- Irrecoverable Operator Errors
 - Paper Empty Sensor 2-12
 - Paper Present Sensor 2-12
 - Paper Select Sensor 2-12

L

- Lubrication 6-1

M

- Menu
 - Interface Menu Options 1-3
 - Setup Menu Options 1-3

O

- Operator Errors
 - Irrecoverable 2-12
- Options 1-6

P

- Paper Jams
 - Clearing Continuous Forms 3-6
 - Clearing Cut Sheet 3-6
- Parts
 - ASF
 - Roller/Support 7-16
 - Side Frame/Covers 7-18
 - Carrier/Paper Feed Left Side 7-10, 7-12



24xx

- Carrier/Paper Feed Right Side 7-6, 7-8
- Coax/Twinax Adapter 7-22
- Covers 7-2
- Electronics 7-14
- Tractor 2 Option 7-20
- Parts Catalog
 - How to use 7-1
- POST 3-2
- Preventive Maintenance
 - Lubrication 6-1
 - Lubrication Points 6-2
 - Specified Lubricants 6-1
- Print Test 3-3
- Printer
 - Description 1-1
 - Options 1-6
 - Settings 1-4
 - Specifications 1-1
 - Speeds 1-1
- Printer Default Settings 3-5

R

- Removals 4-5
 - ASF
 - Gears 4-47
 - Pick-up Roller 4-48
 - Carrier 4-16
 - Carrier Motor Assembly 4-21
 - Covers
 - Bottom 4-12
 - Front 4-6
 - Operator Panel 4-11
 - Option 4-7
 - Ribbon Access 4-6
 - Top 4-8
 - Covers Illustration 4-5
 - Electronics
 - EPROM 4-13
 - Logic Board 4-14
 - Power Supply 4-15
 - Form Thickness Lever 4-25
 - Gears
 - Left Side 4-31
 - Right Side 4-34
 - Operator Panel 4-11

- Paper Feed Motor 4-24
- Paper Select Lever 4-24
- Platen 4-26
- Print Unit 4-28
- Printhead 4-27
- Printhead Cables 4-27
- Ribbon Drive Rack Gear 4-30
- Right Side Sub Frame 4-34
- Rollers
 - Lower Feed 4-41
 - Upper Feed 4-36
 - Upper Pinch 4-38
- Sensors
 - Head Gap 4-44
 - Home Position 4-46
 - Paper Present 4-45
 - Paper Present Flag 4-45
 - Paper Select 4-45
 - Pull Tractor 4-44
 - Top-Of-Form 4-44
 - Top-Of-Form Flag 4-45

- Repair Information 4-1

S

- Safety Information vii
- Service Checks 2-13
 - Abnormal Noise 2-13
 - Abnormal Print 2-21
 - Auto Sheet Feeder 2-14
 - Carrier 2-16
 - Intermittent Problem 2-18
 - No Print 2-21
 - Operator Panel 2-21
 - Paper Feed 2-23
 - Paper Present Sensor 2-22
 - Paper Select Sensor 2-25
 - POST 2-26
 - Power 2-27
 - Print Speed 2-28
 - Printhead 2-29
 - Printhead Continuity Tables 2-30
 - Pull Tractor Sensor 2-31
 - Top-Of-Forms 2-32
 - Tractor 2 2-33
- Settings
 - Tear Off Position 1-4



24xx

- Top-Of-Form (Continuous) 1-5
- Top-Of-Form (Cut Forms) 1-5
- Top-Of-Form (Envelopes) 1-5
- Setup Menu Options 1-3
- Setup Mode 1-2
 - Entering 1-2
 - Exiting 1-2
- Signal Connections 5-2
- Specific Printer Parts 5-1
- Specifications 1-1
- Start 2-1
- Symptom Checks 2-5
 - Abnormal Indications 2-5
 - Abnormal Noise Problems 2-5
 - Abnormal Print Problems 2-6
 - ASF Problems 2-6
 - Error Indications 2-7
 - Operator Panel Problems 2-7
 - Paper Feed Problems 2-7
 - Power Problems 2-9
 - Print Quality Problems 2-10
 - Ribbon Feed Problems 2-11

T

- Tools 1-6

V

- Voltage, Ground, and Continuity 2-1

Part Numbers

- 11A3274 7-7
- 11A3275 7-7
- 11A3283 7-21
- 11A3284 7-21
- 11A3335 7-21
- 11A3336 7-21
- 11A3337 7-21
- 11A3338 7-21
- 11A3341 7-21
- 11A6109 7-22
- 12G3704 7-22
- 12G3705 7-22
- 12G3709 7-22
- 12G3800 7-15
- 12G3801 7-15
- 12G3802 7-15
- 12G3803 7-15
- 12G3804 7-15
- 12G3805 7-15
- 12G3806 7-15
- 12G3807 7-15
- 12G3808 7-15
- 12G3809 7-15
- 12G3810 7-5
- 12G3811 7-5
- 12G3812 7-15
- 12G3813 7-15
- 12G3814 7-17
- 12G3817 7-11
- 12G3818 7-11
- 12G3819 7-7
- 12G3820 7-11
- 12G3821 7-11
- 12G3822 7-7
- 12G3823 7-7
- 12G3824 7-11
- 12G3825 7-11
- 12G3826 7-11
- 12G3827 7-11
- 12G3828 7-11
- 12G3831 7-11
- 12G3832 7-9
- 12G3833 7-9
- 12G3834 7-7
- 12G3835 7-7

**24xx**

12G3836	7-7, 7-15	12G3892	7-11
12G3837	7-7	12G3893	7-17
12G3838	7-7	12G3894	7-7
12G3839	7-7	12G3895	7-7
12G3840	7-7	12G3896	7-7, 7-11
12G3841	7-7	12G3897	7-7
12G3842	7-13	12G3898	7-7
12G3843	7-13	12G3900	7-7
12G3844	7-11	12G3901	7-7
12G3845	7-11	12G3902	7-11
12G3846	7-11	12G3903	7-15
12G3848	7-15	12G3904	7-15
12G3849	7-5	12G3905	7-7, 7-11
12G3850	7-5	12G3906	7-7, 7-11
12G3851	7-5	12G3907	7-7, 7-11, 7-15
12G3852	7-5	12G3908	7-17
12G3853	7-5, 7-21	12G3909	7-11
12G3854	7-5	12G3911	7-17
12G3855	7-5	12G3912	7-17
12G3856	7-5	12G3914	7-17
12G3857	7-5	12G3915	7-17
12G3858	7-3	12G3916	7-17
12G3859	7-3	12G3918	7-17
12G3860	7-15	12G3920	7-19
12G3861	7-15	12G3921	7-19, 7-21
12G3868	7-3	12G3922	7-11
12G3869	7-3	12G3923	7-21
12G3870	7-3	12G3924	7-21
12G3871	7-3	12G3926	7-21
12G3872	7-3	12G3927	7-21
12G3873	7-3	12G3928	7-21
12G3874	7-3	12G3929	7-15
12G3875	7-5	12G3930	7-19, 7-21
12G3876	7-5	12G3931	7-7, 7-13
12G3877	7-3	12G3932	7-7
12G3878	7-3	12G3933	7-17
12G3881	7-5	12G3934	7-17
12G3882	7-5	12G3935	7-11
12G3883	7-5	12G3936	7-15
12G3884	7-7, 7-11	12G3937	7-11
12G3885	7-15	12G3938	7-11
12G3886	7-15	12G3939	7-5, 7-19
12G3887	7-7, 7-15	12G3940	7-11
12G3888	7-7	12G3941	7-11
12G3889	7-7	12G3942	7-7, 7-11
12G3890	7-7	12G3943	7-7
12G3891	7-7	12G3944	7-17

I-4 Service Manual

24xx

12G3945	7-19
12G3946	7-11
12G3947	7-13
12G3948	7-7, 7-11
12G3999	7-5
13A0296	7-22
13A0297	7-22
1333275	7-17
1339517	7-3
1339518	7-3
1339519	7-3
1339520	7-3
1339521	7-3
1339522	7-3
1339523	7-3
1339524	7-3
1339525	7-3
79F4757	7-3
79F4802	7-11
79F4830	7-5
79F4834	7-11
95F6885	7-17
95F6886	7-17
95F6887	7-17
95F6892	7-17, 7-19
95F6893	7-17, 7-19
95F6894	7-17, 7-19
95F6896	7-17
95F6897	7-17

24xx



I-6 Service Manual