



Service Manual

Lexmark 23XX Series

23XX-XXX

- ***Table of Contents***
- ***Start Diagnostics***
- ***Safety and Notices***
- ***Trademarks***
- ***Index***
- ***Manuals Menu***

LEXMARK[™]

Lexmark and Lexmark with diamond design are trademarks of Lexmark International, Inc., registered in the United States and/or other countries.

Edition: April 2000

THE FOLLOWING PARAGRAPH DOES NOT APPLY TO THE UNITED KINGDOM OR ANY COUNTRY WHERE SUCH PROVISIONS ARE INCONSISTENT WITH LOCAL LAW: LEXMARK INTERNATIONAL, INC. PROVIDES THIS PUBLICATION "AS IS" WITHOUT WARRANTY OF ANY KIND, EITHER EXPRESS OR IMPLIED, INCLUDING, BUT NOT LIMITED TO, THE IMPLIED WARRANTIES OF MERCHANTABILITY OR FITNESS FOR A PARTICULAR PURPOSE. Some states do not allow disclaimer of express or implied warranties in certain transactions; therefore, this statement may not apply to you.

This publication could include technical inaccuracies or typographical errors. Changes are periodically made to the information herein; these changes will be incorporated in later editions of the publication. Improvements or changes in the products or the programs described in this publication may be made at any time. Publications are not stocked at the address given below; requests for publications should be made to your point of purchase.

A form for reader's comments is provided at the back of this publication. If the form has been removed, comments may be addressed to Lexmark International, Inc., Department F95/032-2, 740 New Circle Road NW, Lexington, Kentucky 40511, U.S.A. Lexmark may use or distribute any of the information you supply in any way it believes appropriate without incurring any obligation to you.

Lexmark is a trademark of Lexmark International, Inc.

© **Copyright Lexmark International, Inc. 1996, 2000**
All rights reserved.

UNITED STATES GOVERNMENT RESTRICTED RIGHTS

This software and documentation are provided with RESTRICTED RIGHTS. Use, duplication or disclosure by the Government is subject to restrictions as set forth in subparagraph (c)(1)(ii) of the Rights in Technical Data and Computer Software clause at DFARS 252.227-7013 and in applicable FAR provisions: Lexmark International, Inc., Greenwich, CT 06836.

Contents

Notices and Safety Information	ix
Safety Notices	ix
Preface	xiii
General Information	1-1
Description	1-1
Specifications	1-3
Recommended Machine Usage	1-3
Options	1-4
Tools	1-4
Abbreviations	1-5
Setup Mode	1-6
How To Change The Printer Functions	1-6
Serial Interface Adapters	1-7
Serial Interface Switches	1-8
Function Switch Setting	1-8
Diagnostic Information	2-1
Start	2-1
Voltage, Ground, And Continuity Readings	2-1
Error Indication Table	2-2
Symptom/Check Table	2-6
Irrecoverable Operator Errors	2-13
Service Checks	2-14
Abnormal Noise Service Check	2-14
Auto Sheet Feeder (ASF) Service Check	2-15
Carrier Drive, Home Position Sensor, Ribbon Feed Service Check	2-17
Intermittent Problem Service Check	2-20
No Print or Abnormal Print Service Check	2-23
Operator Panel Service Check	2-24
Paper Empty Sensor Service Check	2-26
Paper Feed Service Check	2-27
Paper Select Sensor Service Check	2-30
POST Service Check	2-31
Power Service Check	2-32
Print Speed Service Check	2-34
Printhead Service Check	2-36
Pull Tractor Sensor Service Check	2-38
Top of Forms Problem Service Check	2-39
Tractor 2 Service Check	2-40

Diagnostic Aids	3-1
Power-On Self Test (POST)	3-2
Print Test	3-3
Hex Dump Mode	3-5
Serial Interface Adapter Print Test	3-6
Repair Information	4-1
Handling ESD-Sensitive Parts	4-1
Adjustments	4-2
Printhead-to-Platen Gap Adjustment	4-2
Bidirectional Print Adjustment	4-5
Removal Procedures	4-7
Auto Sheet Feeder Gears Removal	4-8
Auto Sheet Feeder Pick-up Roller Removal	4-9
Bottom Cover Removal	4-10
Carrier Removal	4-12
Carrier Motor Assembly Removal	4-16
Carrier Plate Removal	4-18
Download or Print Buffer Module Removal	4-21
Form Thickness Lever Removal	4-22
Head Gap Sensor Removal (238X-001)	4-23
Head Gap Sensor Removal (23XX-002, 003)	4-24
Home Position Sensor Removal	4-25
Label Jam Removal	4-26
Left Side Frame Removal	4-28
Lower Feed Roller Removal	4-30
Lower Pinch Roller Removal	4-32
Main Logic Board Removal	4-33
Operator Panel Assembly Removal	4-34
Paper Empty Sensor And Spring Removal	4-36
Paper Feed Motor Removal	4-38
Paper Guide Removal (Left And Right)	4-39
Paper Guide / Platen Assembly Removal	4-40
Paper Select Lever Removal	4-42
Paper Select Sensor Removal	4-43
Paper Separator Removal	4-44
Power Supply Removal	4-46
Print Unit Removal	4-47
Printhead Removal	4-48
Printhead Cables Removal	4-49
Pull Tractor Removal	4-50
Pull Tractor Actuator Removal	4-51
Pull Tractor Sensor Removal	4-52

Push Tractor Assembly Removal	4-53
Ribbon Drive Rack Gear Removal	4-54
Right Side Frame Removal	4-56
Right Side Frame Gears Removal	4-58
Sub Logic Board Removal	4-59
Tension Pulley Plate Assembly	4-60
Top Cover Removal	4-61
Top of Form Sensor, Sensor Flag And Spring Removal	4-64
Upper Feed Roller Removal	4-66
Connector Locations	5-1
Front View	5-2
Rear View	5-3
Tractor 2 Cable Connectors	5-4
Wiring Diagrams	5-5
Block Diagram 238X-001	5-5
Block Diagram 239X-001	5-6
Block Diagram 238X-002	5-7
Block Diagram 239X-002	5-8
Block Diagram 238X-003	5-9
Block Diagram 239X-003	5-10
Signal Connections	5-11
Connector Locations	5-20
Main Logic Board 23XX-001	5-20
Main Logic Board 23XX-002	5-21
Main Logic Board 23XX-003	5-22
Sub Logic Boards	5-23
Power Supply	5-25
Operator Panel	5-26
Preventive Maintenance	6-1
Lubrication	6-1
Specified Lubricants	6-1
Lubrication Points	6-2
Lubrication Points (Oil)	6-3
Lubrication Points (Grease)	6-4

Parts Catalog	7-1
How To Use This Parts Catalog.....	7-1
Assembly 1: Major Components	7-2
Assembly 2: Covers	7-6
Assembly 3: Carrier	7-10
Assembly 4: Paper Guide / Platen / Feed Roller	7-16
Assembly 5: Electronics	7-20
Assembly 6: ASF - Roller / Support	7-26
Assembly 7: ASF - Side Frame / Covers	7-28
Assembly 8:Tractor 2 Option	7-30

Notices and Safety Information

Safety Notices

- The maintenance information for this product has been prepared for use by a professional service person and is not intended to be used by others.
- There may be an increased risk of electric shock and personal injury during disassembly and servicing of this product. Professional service personnel should understand this and take necessary precautions.
- The safety features of some parts may not always be obvious. Therefore, replacement parts must have the identical or equivalent characteristics as the original parts.

Sicherheitshinweise

- Die Wartungsinformationen für dieses Produkt sind ausschließlich für die Verwendung durch einen Wartungsfachmann bestimmt.
- Während des Auseinandernehmens und der Wartung des Geräts besteht ein zusätzliches Risiko eines elektrischen Schlags und körperlicher Verletzung. Das zuständige Fachpersonal sollte entsprechende Vorsichtsmaßnahmen treffen.
- Ersatzteile müssen gleiche oder gleichwertige Merkmale wie die Originalteile aufweisen, da nicht immer offensichtlich ist, welche Teile des Geräts Sicherheitsmerkmale aufweisen.

Consignes de Sécurité

- Les consignes d'entretien et de réparation de ce produit s'adressent uniquement à un personnel de maintenance qualifié.
- Le démontage et l'entretien de ce produit pouvant présenter certains risques électriques, le personnel d'entretien qualifié devra prendre toutes les précautions nécessaires.
- Les normes de sécurité de certaines pièces n'étant pas toujours explicites, les pièces de rechange doivent être identiques ou conformes aux caractéristiques des pièces d'origine.

Norme di sicurezza

- Le informazioni riguardanti la manutenzione di questo prodotto sono indirizzate soltanto al personale di assistenza autorizzato.
- Durante lo smontaggio e la manutenzione di questo prodotto, il rischio di subire scosse elettriche e danni alla persona è più elevato. Il personale di assistenza autorizzato, deve, quindi, adottare le precauzioni necessarie.
- Poiché non tutti i pezzi di ricambio garantiscono la stessa sicurezza, questi devono avere caratteristiche identiche o equivalenti a quelle dei pezzi originali.

Pautas de Seguridad

- La información sobre el mantenimiento de este producto está dirigida exclusivamente al personal cualificado de mantenimiento.
- Existe mayor riesgo de descarga eléctrica y de daños personales durante el desmontaje y la reparación de la máquina. El personal cualificado debe ser consciente de este peligro y tomar las precauciones necesarias.
- Los dispositivos de seguridad de algunas piezas no siempre pueden reconocerse a simple vista. Por lo tanto, los recambios deben poseer características idénticas o equivalentes a las de las piezas originales.

Informações de Segurança

- As informações de segurança relativas a este produto destinam-se a profissionais destes serviços e não devem ser utilizadas por outras pessoas.
- Risco de choques eléctricos e ferimentos graves durante a desmontagem e manutenção deste produto. Os profissionais destes serviços devem estar avisados deste facto e tomar os cuidados necessários.
- Os dispositivos de segurança de algumas peças poderão não ser sempre suficientemente evidentes. Assim, as peças sobressalentes devem possuir características idênticas ou equivalentes às peças originais.

Informació de Seguretat

- La informació pel manteniment d'aquest producte està orientada exclusivament a professionals i no està destinada a ningú que no ho sigui.
- El risc de xoc elèctric i de danys personals pot augmentar durant el procés de desmuntatge i de servei d'aquest producte. El personal professional ha d'estar-ne assabentat i prendre les mesures convenients.
- Les característiques de seguretat d'algunes de les peces poden no ser òbvies. Per tant, les característiques dels recanvis hauran de ser idèntiques o equivalents a les de les peces originals.

Chinese Safety Information

安全资讯

- 本产品的维护资讯仅供专业服务人员使用，而非针对一般使用者。
- 本产品在拆卸、维修的时候，遭受电击或人员受伤的危险性会增高，专业服务人员对这点必须有所了解，并采取必要的预防措施。
- 有些零件的安全功能可能不明显。因此，所替换零件的性能一定要与原有的零件一致。

Korean Safety Information

안전 사항

- 본 제품에 관한 유지 보수 설명서는 전문 서비스 기술자 용으로 작성된 것이므로 비 전문가가 사용할 수 없습니다.
- 본제품을 해체하거나 정비할 경우 전기적인 충격을 받거나 상처를 입을 위험이 커집니다. 전문 서비스 기술자는 이 사실을 숙지하고 필요한 예방 조치를 취하도록 하십시오.
- 일부 부품의 안전성은 항상 보장되지 않습니다. 따라서, 교체 부품은 원래 부품과 같거나 동등한 특성을 가진 제품을 사용하여야합니다.

Preface

This manual is divided into the following chapters:

- “General Information” contains a general description of the printer and the maintenance approach used to repair it. Special tools and test equipment are listed in this chapter, as well as general environmental and safety instructions.
- “Diagnostic Information” contains error code table, symptom table, and service checks used to isolate failing field replaceable units (FRUs).
- “Diagnostic Aids” contains tests and checks used to locate or repeat symptoms of printer problems.
- “Repair Information” provides instructions for making printer adjustments and removing and installing FRUs.
- “Connector Locations” uses illustrations to identify the major components and test points on the printer.
- “Preventive Maintenance” contains lubrication specifications, and maintenance information to prevent problems and maintain optimum performance.
- “Parts Catalog” contains illustrations and part numbers for individual FRUs.

1. General Information

Description

The Lexmark 238X and 239X - XXX printers are small versatile tabletop printers suitable for use in the home or small business. They are especially well-suited for applications that use continuous or multipart forms. The 2381 and 2391 are wide-carriage versions of the 2380 and 2390.

The 23XX Plus (23XX-002) printers are enhanced versions of the basic 23XX-001 printers. These printers have the following additional features:

- Forms macro and smooth paper scrolling capability, available from the operator panel.
- Option slot.
- Resident bar code.
- Quiet mode.
- Higher print speed (239X).

The 23XX Forms Printers (23XX-003), in addition to the features of the 23XX-002 printers are 9% (9-wire machines) or 28% (24-wire machines) faster in fast draft mode. They also support the Tractor 2 Options.

There is also a PS/1 version of the 2390-001, which has a distinctive PS/1 logo but is otherwise identical to the 2390-001.

The following table summarizes the differences between the printers in the 23XX family:

US Logo Name	WTC Logo Name	Mach Type Model #	No. of Print Wires	Paper Width	Paper Knob
PPSII 2380	2380	2380-001	9	Narrow	Yes
PPSII 2381	2381	2381-001	9	Wide	Yes
PPSII 2390	2390	2390-001	24	Narrow	Yes
PPSII 2391	2391	2391-001	24	Wide	Yes
PS/1	N/A	2390-PS1	24	Narrow	Yes
2380 Plus	2380 Plus	2380-002	9	Narrow	No
2381 Plus	2381 Plus	2381-002	9	Wide	No
2390 Plus	2390 Plus	2390-002	24	Narrow	No
2391 Plus	2391 Plus	2391-002	24	Wide	No
Forms Printer 2380 Plus	Forms Printer 2380 Plus	2380-003	9	Narrow	No
Forms Printer 2381 Plus	Forms Printer 2381 Plus	2381-003	9	Wide	No
Forms Printer 2390 Plus	Forms Printer 2390 Plus	2390-003	24	Narrow	No
Forms Printer 2391 Plus	Forms Printer 2391 Plus	2391-003	24	Wide	No

Specifications

- Printhead life: 140 Million Characters
- Ribbon Life: 4 Million Characters
- Printer Life: 5 Years
- BTU: 409-Maximum/51 Idle (Per Hour)
- Power Consumption: 120 Watts-Maximum/15 Watts Idle

Recommended Machine Usage

- 23XX-001 - 10 million characters per year.
- 23XX-002, 003 - 12 million characters per year.

The character usage per day is calculated by dividing the yearly usage rating by 1300 characters per page, divided by 12 months per year, by 22 working days per month. To reduce the probability of reliability/service problems, field data has shown printer usage should not exceed twice the daily page usage.

Notes:

- All numbers are average or estimates.
- Performance of individual printers may vary.
- Lexmark does not represent or warrant that printers will achieve these results. (See the applicable statement of Limited Warranty for all warranty information).

Options

The following options may be installed on 238X/239X printers:

- Auto Sheet Feeder (ASF)
- 32Kb Memory Module, Volatile
- 32Kb Memory Module, Non-volatile
- Serial Interface Attachment (RS232/RS422).
- Extended National Language Support modules (World Trade only)
- Acoustics Option
- Extended Cut-sheet Paper Guides
- Tractor 2 (23XX-003 Only)

Tools

The basic tools needed are:

- Basic CE tool kit
- #1 Phillips screwdriver
- #2 Phillips screwdriver
- Feeler gauges 0.35 mm (0.014 in.) 0.4 mm (0.016 in.)
- Analog or digital volt-ohmmeter

Abbreviations

ASIC	Application-Specific Integrated Circuit
CSU	Customer Setup
DRAM	Dynamic Random Access Memory
EPROM	Erasable Programmable Read-Only Memory
ESD	Electrostatic Discharge
FRU	Field Replaceable Unit
HVPS	High Voltage Power Supply
LAN	Local Area Network
LCD	Liquid Crystal Display
LED	Light-Emitting Diode
LVPS	Low Voltage Power Supply
NVRAM	Nonvolatile Random Access Memory
OEM	Original Equipment Manufacturer
POR	Power-On Reset
POST	Power-On Self Test
PQET	Print Quality Enhancement Technology
ROS	Read-Only Storage
SRAM	Static Random Access Memory
UPR	Used Parts Replacement
V ac	Volts alternating current
V dc	Volts direct current

Setup Mode

How To Change The Printer Functions

1. Make sure continuous forms are in the printer.
2. Press **Alt** and then press **Setup** to enter Setup Mode. The printer prints out the Main Menu.
3. To select a function, press the buttons listed on the printout.
4. To save the setting and leave Setup Mode, press **Start/Stop** until out of the menu.

Serial Interface Adapters

The 23XX printer product line uses three different serial adapters.

- **23XX-001:**
 - Snaps on back of the printer and plugs into the parallel port.
 - Power lead plugs into the printer's +5 V port.
 - Switch settings are for "Snap-On".
- **23XX-002:**
 - In-line gray box with a short cable to the parallel port.
 - Some units have a separate power lead to the +5 V port.
 - Units without the power cord will not work on the 23XX-001.
 - Switch settings are for "Gray".
- **23XX-003:**
 - Similar to the 23XX-002, but different switch definitions.
 - All units have a power lead.
 - Switch settings are for "Black".

Notes:

- Except as noted, all adapters work with all printers.
- Some adapters may be installed on printers other than what is listed.
- Only the "Black" adapter is available as a FRU.
- Changes to switch settings are valid only after printer power is turned off and then on again.
- Contact Lexmark Technical Support for questions about serial adapters.

Serial Interface Switches

The serial interface has 12 function switches which determine how the printer receives data from the computer or terminal. Set the switches according to your particular equipment requirements.

Function Switch Setting

Switches 1 To 4 - Speed:

Define the serial interface speed in bits per second (bps).

Snap-On and Gray Serial Adapters

Switch 1	Switch 2	Switch 3	Switch 4	Speed (bps)
On	On	Off	Off	150
On	Off	On	Off	300
On	Off	Off	Off	600
Off	On	On	Off	1,200
Off	On	Off	Off	2,400
Off	Off	On	Off	4,800
Off	Off	Off	Off	9,600
On	On	On	Off	19,200
Off	Off	Off	On	38,400 (RS-422 only)

Black Serial Adapter

Switch 1	Switch 2	Switch 3	Speed (bps)
N/A	N/A	N/A	150
On	Off	On	300
On	Off	Off	600
Off	On	On	1,200
Off	On	Off	2,400
Off	Off	On	4,800
Off	Off	Off	9,600
On	On	On	19,200
On	On	Off	38,400 (RS-422 Only)

Switch 5 - Data Bits:

Selects the number of data bits (7 or 8) in each data frame.

Switch 5	Data Bits
Off	8
On	7

Switches 6 and 7 - Parity:

Select the interface parity.

Switch 6	Switch 7	Parity
Off	Off	No
Off	On	Ignore
On	Off	Odd
On	On	Even

Note: When setting the “Ignore” for parity, the printer ignores the received parity and transmits using even parity. For all other parity settings, the transmitted parity matches the received parity.

Switch 8 - Stop Bits (Snap-On):.

Switch 8	Stop Bits
Off	1 Stop Bit
On	2 Stop Bits

Switch 8 - Buffer Size (Gray and Black):

Selects the buffer size.

Switch 8	Buffer Size
Off	Normal (2048 bytes)
On	Minimum (2 bytes)

Switch 9 - Protocol:

Selects the type of protocol. Differs depending on which serial interface unit is installed.

Snap-On and Gray Units

Switch 9	Protocol	
	Snap-On	Gray
Off	XON/XOFF	DTR Pacing (RS232 only)
On	DTR pacing (RS232 only)	XON/XOFF

Black Units

Switch 4	Switch 9	Protocol
Off	On	XON/XOFF
Off	Off	DTR pacing (RS232 only)
On	Off	DTR + XON/XOFF
Off	On	Robust XON/XOFF

Note: DTR protocol is for RS-232C only.

Switch 10 - Print Test (All Units):

Selects the print test for the serial interface adapter. Refer to “Serial Interface Adapter Print Test” on page 3-6.

Switch 10	Print Test
Off	Normal mode
On	Test mode

Switch 11- Polarity For RS-422 Serial Interface (All Units):

NOR/REV reverses the polarity of the receive and transmit data line for the RS-422 serial interface.

Switch 11	Mode
Off	Normal
On	Reverse

Switch 12 - Serial Interface Mode Select: (All Units)

Switch 232/422 sets the serial interface in either RS-232C or RS-422 mode.

Switch 12	Mode
Off	RS-232C
On	RS-422

2. Diagnostic Information

Start

Make a quick visual check for defects (loose or broken parts, unplugged connectors, paper jams, and so on).

Voltage, Ground, And Continuity Readings

Voltage Readings

All DC voltages must be within +5% through -10% of the values to be considered correct. Unless stated otherwise, all connectors should be connected normally when a voltage measurement is done.

When a “Line Voltage” measurement is to be done, the voltage on United States and Canada machines should be between 100 V ac and 127 V ac. On World Trade machines, the voltage is according to each country’s specification.

Ground Checks

To check for a correct ground, measure the voltage between the ground and a known good voltage source. The voltage measurement must be the same as the source voltage to consider that the ground is correct. Continuity measurements may be used to check grounds, however, be sure to measure to a known good ground using the lowest ohms scale and check for zero ohms.

Note: Always unplug the power cord before doing any continuity measurement.

Continuity Readings

When measuring continuity, be sure no back circuits affect the measurement. If necessary, unplug connectors to remove any back circuits. Zero the ohm range on the lowest scale (X1). An open circuit will read infinity. A circuit with correct continuity will read zero ohms.

Error Indication Table

The following table describes the service check entries for the printer error indication codes.

When an error indication changes after you have entered a service check, you have an intermittent problem. If this occurs, leave the service check and go to **“Symptom/Check Table” on page 2-6.**

Indication		Alarm	Action																
<table border="1"> <thead> <tr> <th>LED</th> <th>Status</th> </tr> </thead> <tbody> <tr> <td>Power</td> <td>ON</td> </tr> <tr> <td>Ready</td> <td>ON</td> </tr> <tr> <td>Paper</td> <td>ON</td> </tr> <tr> <td>Font</td> <td>ON</td> </tr> <tr> <td>Pitch</td> <td>ON</td> </tr> <tr> <td>Alt</td> <td>ON</td> </tr> <tr> <td>Others</td> <td>ON</td> </tr> </tbody> </table>		LED	Status	Power	ON	Ready	ON	Paper	ON	Font	ON	Pitch	ON	Alt	ON	Others	ON	None	Post Error Go to “POST Service Check” on page 2-31.
LED	Status																		
Power	ON																		
Ready	ON																		
Paper	ON																		
Font	ON																		
Pitch	ON																		
Alt	ON																		
Others	ON																		
<table border="1"> <thead> <tr> <th>LED</th> <th>Status</th> </tr> </thead> <tbody> <tr> <td>Power</td> <td>ON</td> </tr> <tr> <td>Ready</td> <td>ON</td> </tr> <tr> <td>Paper</td> <td>ON</td> </tr> <tr> <td>Font</td> <td>ON</td> </tr> <tr> <td>Pitch</td> <td>ON</td> </tr> <tr> <td>Alt</td> <td>ON</td> </tr> <tr> <td>Others</td> <td>OFF</td> </tr> </tbody> </table>		LED	Status	Power	ON	Ready	ON	Paper	ON	Font	ON	Pitch	ON	Alt	ON	Others	OFF	None	RAM, ROM, Timer Interrupt Controller Error Turn the machine off and then on. If you get the same error during power-up, replace the main logic board and readjust the bidirectional print adjustment. If the printer completes POST successfully and eventually gets the same error, go to “Intermittent Problem Service Check” on page 2-20.
LED	Status																		
Power	ON																		
Ready	ON																		
Paper	ON																		
Font	ON																		
Pitch	ON																		
Alt	ON																		
Others	OFF																		

Indication		Alarm	Action																
<table border="1"> <thead> <tr> <th>LED</th> <th>Status</th> </tr> </thead> <tbody> <tr> <td>Power</td> <td>ON</td> </tr> <tr> <td>Ready</td> <td>BLINK</td> </tr> <tr> <td>Paper</td> <td>BLINK</td> </tr> <tr> <td>Font</td> <td>OFF</td> </tr> <tr> <td>Pitch</td> <td>BLINK</td> </tr> <tr> <td>Alt</td> <td>OFF</td> </tr> <tr> <td>Others</td> <td>OFF</td> </tr> </tbody> </table>		LED	Status	Power	ON	Ready	BLINK	Paper	BLINK	Font	OFF	Pitch	BLINK	Alt	OFF	Others	OFF	None	<p>Switch Scan Test Error</p> <p>Go to “Operator Panel Service Check” on page 2-24.</p>
LED	Status																		
Power	ON																		
Ready	BLINK																		
Paper	BLINK																		
Font	OFF																		
Pitch	BLINK																		
Alt	OFF																		
Others	OFF																		
<table border="1"> <thead> <tr> <th>LED</th> <th>Status</th> </tr> </thead> <tbody> <tr> <td>Power</td> <td>ON</td> </tr> <tr> <td>Ready</td> <td>BLINK</td> </tr> <tr> <td>Paper</td> <td>BLINK</td> </tr> <tr> <td>Font</td> <td>BLINK</td> </tr> <tr> <td>Pitch</td> <td>OFF</td> </tr> <tr> <td>Alt</td> <td>OFF</td> </tr> <tr> <td>Others</td> <td>OFF</td> </tr> </tbody> </table>		LED	Status	Power	ON	Ready	BLINK	Paper	BLINK	Font	BLINK	Pitch	OFF	Alt	OFF	Others	OFF	None	<p>NVRAM Read/Write Error</p> <p>Turn the machine off and then back on. If you get the same error during power-up, replace the main logic board and readjust the bidirectional print adjustment. If the printer completes POST successfully and eventually gets the same error, go to “Intermittent Problem Service Check” on page 2-20.</p>
LED	Status																		
Power	ON																		
Ready	BLINK																		
Paper	BLINK																		
Font	BLINK																		
Pitch	OFF																		
Alt	OFF																		
Others	OFF																		
<table border="1"> <thead> <tr> <th>LED</th> <th>Status</th> </tr> </thead> <tbody> <tr> <td>Power</td> <td>ON</td> </tr> <tr> <td>Ready</td> <td>BLINK</td> </tr> <tr> <td>Paper</td> <td>BLINK</td> </tr> <tr> <td>Font</td> <td>BLINK</td> </tr> <tr> <td>Pitch</td> <td>BLINK</td> </tr> <tr> <td>Alt</td> <td>OFF</td> </tr> <tr> <td>Others</td> <td>OFF</td> </tr> </tbody> </table>		LED	Status	Power	ON	Ready	BLINK	Paper	BLINK	Font	BLINK	Pitch	BLINK	Alt	OFF	Others	OFF	Beeps 10 times	<p>Home Position Error</p> <p>Go to “Carrier Drive, Home Position Sensor, Ribbon Feed Service Check” on page 2-17.</p> <p>Tractor 2 Home Position Error</p> <p>If Tractor 2 is installed, remove it to determine whether the problem is with the carrier home sensor or the Tractor 2 home sensor. Refer to the “Tractor 2 Service Check” on page 2-40.</p>
LED	Status																		
Power	ON																		
Ready	BLINK																		
Paper	BLINK																		
Font	BLINK																		
Pitch	BLINK																		
Alt	OFF																		
Others	OFF																		
		None	<p>Home Position Error Without Alarm</p> <p>Go to “Power Service Check” on page 2-32.</p>																

Indication		Alarm	Action																
<table border="1"> <thead> <tr> <th>LED</th> <th>Status</th> </tr> </thead> <tbody> <tr> <td>Power</td> <td>ON</td> </tr> <tr> <td>Ready</td> <td>BLINK</td> </tr> <tr> <td>Paper</td> <td>BLINK</td> </tr> <tr> <td>Font</td> <td>BLINK</td> </tr> <tr> <td>Pitch</td> <td>OFF</td> </tr> <tr> <td>Alt</td> <td>BLINK</td> </tr> <tr> <td>Others</td> <td>OFF</td> </tr> </tbody> </table>		LED	Status	Power	ON	Ready	BLINK	Paper	BLINK	Font	BLINK	Pitch	OFF	Alt	BLINK	Others	OFF	None	<p>Logical Error</p> <p>Turn the machine off and then back on. If you get the same error during power-up, replace the main logic board and readjust the bidirectional print adjustment. If the printer completes POST successfully and eventually gets the same error check, go to “Intermittent Problem Service Check” on page 2-20.</p>
LED	Status																		
Power	ON																		
Ready	BLINK																		
Paper	BLINK																		
Font	BLINK																		
Pitch	OFF																		
Alt	BLINK																		
Others	OFF																		
<table border="1"> <thead> <tr> <th>LED</th> <th>Status</th> </tr> </thead> <tbody> <tr> <td>Power</td> <td>ON</td> </tr> <tr> <td>Ready</td> <td>BLINK</td> </tr> <tr> <td>Paper</td> <td>BLINK</td> </tr> <tr> <td>Font</td> <td>OFF</td> </tr> <tr> <td>Pitch</td> <td>BLINK</td> </tr> <tr> <td>Alt</td> <td>BLINK</td> </tr> <tr> <td>Others</td> <td>OFF</td> </tr> </tbody> </table>		LED	Status	Power	ON	Ready	BLINK	Paper	BLINK	Font	OFF	Pitch	BLINK	Alt	BLINK	Others	OFF	None	<p>Hardware Drive Error</p> <p>The printhead or the printhead cables can cause this error. Go to “Printhead Service Check” on page 2-36.</p> <p>Turn the machine off and then back on. If you get the same error, replace the main logic board and readjust the “Bidirectional Print Adjustment” on page 4-5. If the printer completes POST successfully and eventually gets the same error, go to “Intermittent Problem Service Check” on page 2-20.</p> <p>If the problem still exists, remove the new main logic board, install the old main logic board, then replace the sub logic board.</p>
LED	Status																		
Power	ON																		
Ready	BLINK																		
Paper	BLINK																		
Font	OFF																		
Pitch	BLINK																		
Alt	BLINK																		
Others	OFF																		
<table border="1"> <thead> <tr> <th>LED</th> <th>Status</th> </tr> </thead> <tbody> <tr> <td>Power</td> <td>OFF</td> </tr> <tr> <td>Ready</td> <td>OFF</td> </tr> <tr> <td>Paper</td> <td>OFF</td> </tr> <tr> <td>Font</td> <td>OFF</td> </tr> <tr> <td>Pitch</td> <td>OFF</td> </tr> <tr> <td>Alt</td> <td>OFF</td> </tr> <tr> <td>Others</td> <td>OFF</td> </tr> </tbody> </table>		LED	Status	Power	OFF	Ready	OFF	Paper	OFF	Font	OFF	Pitch	OFF	Alt	OFF	Others	OFF	None	<p>Power Failure</p> <p>Check the continuity of the power cord and the voltage of the user’s outlet. If they are correct, go to “Power Service Check” on page 2-32.</p>
LED	Status																		
Power	OFF																		
Ready	OFF																		
Paper	OFF																		
Font	OFF																		
Pitch	OFF																		
Alt	OFF																		
Others	OFF																		

Indication	Alarm	Action																
<table border="1"> <thead> <tr> <th data-bbox="136 224 248 261">LED</th> <th data-bbox="248 224 345 261">Status</th> </tr> </thead> <tbody> <tr> <td data-bbox="136 261 248 293">Power</td> <td data-bbox="248 261 345 293">ON</td> </tr> <tr> <td data-bbox="136 293 248 326">Ready</td> <td data-bbox="248 293 345 326">OFF</td> </tr> <tr> <td data-bbox="136 326 248 358">Paper</td> <td data-bbox="248 326 345 358">OFF</td> </tr> <tr> <td data-bbox="136 358 248 391">Font</td> <td data-bbox="248 358 345 391">OFF</td> </tr> <tr> <td data-bbox="136 391 248 423">Pitch</td> <td data-bbox="248 391 345 423">OFF</td> </tr> <tr> <td data-bbox="136 423 248 456">Alt</td> <td data-bbox="248 423 345 456">OFF</td> </tr> <tr> <td data-bbox="136 456 248 488">Others</td> <td data-bbox="248 456 345 488">OFF</td> </tr> </tbody> </table>	LED	Status	Power	ON	Ready	OFF	Paper	OFF	Font	OFF	Pitch	OFF	Alt	OFF	Others	OFF	None	<p>Operator Panel Failure</p> <p>Go to “Operator Panel Service Check” on page 2-24.</p>
LED	Status																	
Power	ON																	
Ready	OFF																	
Paper	OFF																	
Font	OFF																	
Pitch	OFF																	
Alt	OFF																	
Others	OFF																	
If other LED combinations along with the Power LED are on.	None	Go to “POST Service Check” on page 2-31.																
Any LED on but the Power LED off.	None	Go to “Operator Panel Service Check” on page 2-24.																
If the Power LED blinks or changes intensity.	None	Go to “Power Service Check” on page 2-32.																
Any	Beeps 7 times	<p>(Optional Serial Interface Adapter installed)</p> <ul style="list-style-type: none"> • Turn the printer off and check the connection from the serial interface adapter to the printer. • Turn the printer off and then on. If you get the same error, replace the serial interface adapter. • If turning the printer off and then on is successful, run the “Serial Interface Adapter Print Test” on page 3-6. 																

Symptom/Check Table

1. Select the symptom that best describes the problem.
2. Perform the appropriate action before you go to the indicated service check.

Abnormal Indications

Symptom	Action
<p>7 or more lights turn on but do not turn off.</p> <p>The Power light is on, but POST will not run.</p>	<p>Disconnect the interface cable from the printer and turn the printer off and then on. If POST now runs correctly, the problem is in the computer or interface cable.</p> <p>Go to the “POST Service Check” on page 2-31.</p>

Abnormal Noise Problems

Symptom	Action
<p>During POST, abnormal noise comes from the carrier.</p>	<p>Check the ribbon cartridge for binds or damage.</p> <p>Go to the “Carrier Drive, Home Position Sensor, Ribbon Feed Service Check” on page 2-17.</p>
<p>During idling, abnormal noise comes from the printer.</p> <p>When feeding paper, abnormal noise is created.</p> <p>During printing or POST, abnormal noise is created.</p>	<p>Go to “Abnormal Noise Service Check” on page 2-14.</p>

Abnormal Print Operation Problems

Symptom	Action
<p>Printer will not print, or become Ready.</p> <p>Abnormal operation, incorrect characters, or incorrect line width.</p> <p>Printer is ready but will not print from the computer correctly.</p> <p>Undefined or incorrect character(s).</p>	<p>Be sure the interface cable is connected properly.</p> <p>If the serial interface adapter is installed, be sure it and its power interface cable are installed correctly. (Some adapters do not have a separate power cable.)</p> <p>Go to the “No Print or Abnormal Print Service Check” on page 2-23.</p>
<p>Slow printing speed.</p>	<p>Go to the “Print Speed Service Check” on page 2-34.</p>

Auto Sheet Feeder Problems

Symptom	Action
<p>Auto sheet feeder will not feed paper.</p> <p>Auto sheet feeder double feeds.</p> <p>Auto sheet feeder has intermittent feed problems.</p>	<p>Be sure Sheet Feed is enabled in the Setup Mode.</p> <p>Be sure the paper select lever is in the cut sheet position.</p> <p>Go to the “Auto Sheet Feeder (ASF) Service Check” on page 2-15.</p>

Error Indications

Symptom	Action
Ready and Paper Out lights blink to indicate a Hardware Error.	Turn the printer off and then on. Go to “Abnormal Indications” on page 2-6.
Paper Out and Alt lights blink to indicate an operator error.	Turn the printer off and then on. Go to “Irrecoverable Operator Errors” on page 2-13.

Paper Feed Problems

Symptom	Action
Paper Out is blinking with paper in the printer.	Go to the “Paper Empty Sensor Service Check” on page 2-26.
Paper Out does not blink when no paper is in the printer and ASF is not installed. Print operation starts without paper.	Be sure the paper empty sensor is not blocked. Go to the “Paper Empty Sensor Service Check” on page 2-26.
Alt + Park/Load does not function when the push tractor is installed. Form feed length is not correct. Alt + Park/Load functions with cut sheets in use.	Be sure the paper select lever is in the correct position. Go to the “Paper Select Sensor Service Check” on page 2-30.

Symptom	Action
<p>Paper feeds, but Auto Loading does not work.</p>	<p>Be sure the paper select lever is in the cut sheet position.</p> <p>Be sure Auto Loading is enabled in the Setup Mode.</p> <p>Go to the “Paper Select Sensor Service Check” on page 2-30.</p>
<p>Alt + Park/Load functions when the pull tractor is installed.</p> <p>With Paper Out blinking, Form Feed does not operate until paper is located at first print line.</p>	<p>Be sure the paper select lever is in the tractor position.</p> <p>Go to the “Pull Tractor Sensor Service Check” on page 2-38.</p>
<p>Lower feed roll shaft rotates, but paper does not feed.</p> <p>Pressing Form Feed does not feed paper.</p> <p>Abnormal noise created while feeding.</p> <p>Paper jams, skews or creases.</p> <p>Incorrect or no line spacing: wider, narrower, or overlapping lines.</p> <p>Push/Pull Tractor does not work.</p>	<p>Be sure the paper select lever is in the correct position.</p> <p>Go to the “Paper Feed Service Check” on page 2-27.</p>
<p>Incorrect Top of Form positioning.</p>	<p>Go to the “Top of Forms Problem Service Check” on page 2-39.</p>

Operator Panel Problems

Symptom	Action
<p>Start/Stop does not function but no error is indicated.</p> <p>Only the Power light turns on.</p> <p>One or more buttons do not function.</p> <p>One or more lights do not function.</p>	<p>Turn the printer off and then on.</p> <p>Go to the “Operator Panel Service Check” on page 2-24.</p>

Power Problems

Symptom	Action
<p>When the power switch is on, the Power light does not turn on or the printer does not start.</p> <p>The Power light blinks or changes intensity.</p>	<p>Check continuity of the power cord and the voltage of the user's outlet.</p> <p>Go to the “Power Service Check” on page 2-32.</p>

Print Quality Problems

Symptom	Action
No print, but carrier moves as if printing.	<p>Adjust the form thickness lever to a lower number.</p> <p>Be sure the printhead cables are not loose or damaged.</p> <p>Be sure the interface cable is connected properly.</p> <p>Be sure the serial interface adapter is installed correctly and the dip switches are set correctly.</p> <p>Check the ribbon cartridge for binds or damage.</p> <p>Go to the “Print Speed Service Check” on page 2-34.</p>
Print density is light.	<p>Verify that the ribbon density control knob on the ribbon cartridge is not set to 0.</p> <p>If the ribbon has reached its end of life or is worn, the ribbon cartridge needs to be replaced.</p> <p>Go to the “Carrier Drive, Home Position Sensor, Ribbon Feed Service Check” on page 2-17.</p>
<p>Uneven print density across the print line.</p> <p>Specific dots missing.</p> <p>Extra dots or lines printing.</p>	<p>Be sure the printhead cables are connected correctly to the printhead and the sub logic board.</p> <p>Clean the printhead.</p> <p>Set the form thickness lever to position “1” and run the print test.</p> <p>Go to the “Carrier Drive, Home Position Sensor, Ribbon Feed Service Check” on page 2-17.</p>
<p>Scattered ink smearing, blurred characters.</p> <p>Fuzzy print.</p>	<p>Clean the printhead nose.</p> <p>Clean the ribbon guide and shield.</p> <p>If the ribbon has reached its end of life or is worn, the ribbon cartridge needs to be replaced.</p> <p>Go to the “Carrier Drive, Home Position Sensor, Ribbon Feed Service Check” on page 2-17.</p>

Symptom	Action
Wavy vertical lines, uneven left margin or character width is reduced.	Clean and lubricate the carrier shaft. If the carrier drive belt is worn or broken, replace the carrier unit. Go to the “Carrier Drive, Home Position Sensor, Ribbon Feed Service Check” on page 2-17.

Ribbon Feed Problems

Symptom	Action
Ribbon comes off, becomes loose or folded, or jams. Ribbon feeds correctly but is noisy.	Check the ribbon cartridge for binds or damage. Go to the “Carrier Drive, Home Position Sensor, Ribbon Feed Service Check” on page 2-17.

Irrecoverable Operator Errors

Alt and **Paper Out** lights blink to indicate an operator error. If this indication cannot be recovered, the problem may be the paper empty sensor or the paper select sensor. Check the following in the order listed and if the printer does not work correctly, go to the indicated service check.

Paper Empty Sensor

Action	Check
Remove all paper from the printer. Turn the power on.	Paper Out blinks when paper does not exist. Paper Out turns off when paper exists. Go to the "Paper Empty Sensor Service Check" on page 2-26.

Paper Select Sensor

Action	Check
Turn the power off. Install the Push Tractor. Set the paper select lever to the tractor position and load the continuous forms. Turn the power on.	Alt + Park/Load function correctly. Go to the "Paper Select Sensor Service Check" on page 2-30.
Remove the continuous forms. Set the paper select lever to the cut sheet position and insert a cut sheet.	When Auto Loading is enabled, paper feeds automatically. When Auto Loading is disabled, press Form Feed to load a cut sheet. Check that Alt + Park/Load does not function. Go to the "Paper Select Sensor Service Check" on page 2-30.

Service Checks

Abnormal Noise Service Check

Check the entire printer for loose parts.

	FRU	Action
1	Ribbon Cartridge	Remove and reinstall the ribbon cartridge.
2	Printhead	Disconnect the printhead cables. Run the print test (do not fold or damage the cables during the test). Replace the printhead if the noise is gone.
3	Carrier Motor Ribbon Drive Mechanism	Disconnect the carrier motor connector CN9 from the main logic board, and turn the printer off and then on. If the abnormal noise is gone, look for a problem with the carrier motor or ribbon drive mechanism.
4	Paper Feed Mechanism	Disconnect the paper feed motor from CN10 from the main logic board. Perform the Print Test. If the abnormal noise is gone, look for the problem in the paper feed mechanism.

Auto Sheet Feeder (ASF) Service Check

Note: Be sure the sheet feeder is enabled. Refer to “Setup Mode” on page 1-6.

Auto Sheet Feeder Principles of Operation

The auto-sheet feeder (ASF) feeds into the cut sheet paper entry throat. To use the ASF:

- The paper select lever must be set to cut sheet.
- Auto Sheet Feeder must be selected in the Setup menu.

Continuous forms can be used with the ASF installed by moving the paper select lever to continuous forms and pressing Start to feed the continuous forms to the first print line.

The ASF contains no electrical parts. It is driven from the gear on the inside of the printer’s right side frame.

The combination lock mechanism is a clutch that causes the ASF pick rollers to feed only one sheet of paper at a time. When **Auto Sheet Feeder** is selected on the Setup Menu, the cut sheet paper drive reverses itself for a short distance during paper loading. This reversal engages the clutch and thus engages the paper picker rollers, which feed the top sheet from the cut sheet paper stack. The sheet is fed about 5 inches (125 mm) and the paper path briefly reverses again; this disengages the clutch and the picker rollers. The sheet is then fed to the print line by the ASF’s upper and lower feed rollers and the printer’s lower feed rollers. Although the ASF picker rollers continue to turn as the paper is fed, their drive is disengaged and they are actually being turned by the paper.

	FRU	Action
1	Paper Select Sensor	With the paper select lever in the cut sheet position, do the following: <ul style="list-style-type: none">• Try to load a sheet with Alt+Park/Load. (This button should not work)• If the paper loads go to the “Paper Select Sensor Service Check” on page 2-30.

	FRU	Action
2	Paper Feed	<p>If the paper does not feed, do the following:</p> <ul style="list-style-type: none">• Remove the ASF.• Be sure the base printer feeds paper correctly.• If it does not feed paper correctly, go to the “Paper Feed Service Check” on page 2-27.
3	Gear Train	<p>Be sure the ASF drive gear on the inside of the printer's right frame rotates.</p> <p>Inspect the right side gear train for damage or debris.</p> <p>Remove the ASF right cover and ensure that all gears are in good condition.</p>
4	Combination Lock Mechanism	<p>Install the ASF and press Form Feed.</p> <p>If the picker drive shaft does not rotate, replace the combination lock mechanism.</p>
5	Left and Right Hoppers	<p>If the ASF picker rollers rotate but a single sheet is not picked, inspect the springs and corner separators on the left and right hoppers.</p> <p>Make sure the paper load lever is in the correct position.</p>

Carrier Drive, Home Position Sensor, Ribbon Feed Service Check

23XX-001 only: If the carrier stops but the print wires continue to fire (printing one vertical column of dots), or if the carrier does not move after turning the printer off and then on, inspect the area of the main logic board that is below the paperfeed motor. If this area is damaged or cracked, replace the main logic board. Also check the continuity of soldered-on fuse FU1 located on the main logic board near the paper empty sensor. If this fuse is open, replace the main logic board. Turn the printer off and then on. The carrier should move to the left, contact the home position sensor on the left side frame, and immediately move slightly away from the sensor.

A Home Position Error occurs when:

- The sensor is not closed.
- The sensor is not quickly opened.
- The sensor is closed any time other than when the printer is turned off and then on.

	FRU	Action
1	Carrier	<p>If there is no Home Position Error, check the carrier belt and the ribbon cartridge for wear or damage. Check the belt and pulley engagement.</p> <p>Manually move the carrier the full length of the carriage to check for binds and to make sure the ribbon advances when the carriage moves in either direction.</p> <p>If the carrier binds check the following:</p> <ul style="list-style-type: none"> • Correct printhead-to-platen gap. • Clean and lubricated carrier shaft. • Idler pulley not binding. • Ribbon drive rack gear teeth not damaged. <p>If the carrier still binds:</p> <p>Remove the belt and move the carrier again. If the bind is gone, replace the carrier motor. If the bind still exists, replace the carrier.</p>
2	Home Position Sensor Sub Logic Board Short Flexible Cable	<p>If the carrier moves manually without binding but the Home Position Error still occurs, verify that the main logic board is receiving +26 V dc on pin CP11-1. Check that the 5 V dc home position sensor signal is getting to the main logic board. Check CP3-7 on the main logic board. Check CP6-1 on the sub logic board.</p> <p>Replace the sensor, the sub logic board, or the short flexible cable as necessary.</p>

	FRU	Action												
3	Carrier Motor	<p>If the home position sensor is OK, refer to the table and make sure the resistance of the carrier motor windings are from 1 to 5 ohms for all printers.</p> <table border="0"> <tr> <td>238X-001,002,003</td> <td></td> </tr> <tr> <td>239X-002,003</td> <td>239X-001</td> </tr> <tr> <td>CP9-1 & CP9-5</td> <td>CP9-1 & CP9-6</td> </tr> <tr> <td>CP9-2 & CP9-6</td> <td>CP9-2 & CP9-5</td> </tr> <tr> <td>CP9-3 & CP9-5</td> <td>CP9-3 & CP9-6</td> </tr> <tr> <td>CP9-4 & CP9-6</td> <td>CP9-4 & CP9-5</td> </tr> </table>	238X-001,002,003		239X-002,003	239X-001	CP9-1 & CP9-5	CP9-1 & CP9-6	CP9-2 & CP9-6	CP9-2 & CP9-5	CP9-3 & CP9-5	CP9-3 & CP9-6	CP9-4 & CP9-6	CP9-4 & CP9-5
238X-001,002,003														
239X-002,003	239X-001													
CP9-1 & CP9-5	CP9-1 & CP9-6													
CP9-2 & CP9-6	CP9-2 & CP9-5													
CP9-3 & CP9-5	CP9-3 & CP9-6													
CP9-4 & CP9-6	CP9-4 & CP9-5													
4	Main Logic Board	<p>If all parts appear OK but the Home Position Error still occurs, replace the main logic board.</p> <p>After replacing the main logic board or any parts affecting the carrier, perform the bidirectional print adjustment. See “Bidirectional Print Adjustment” on page 4-5.</p>												

Intermittent Problem Service Check

	FRU/Symptom	Action
1	The machine sometimes fails before POST is complete.	<p>Check for the following:</p> <ol style="list-style-type: none"> 1. Loose connectors. Reconnect all connectors to the main and sub logic boards. 2. Electrical noise or static discharge. Check the following items: <ul style="list-style-type: none"> • Power supply ground. • Machine frame ground. • Printer interface cable is grounded and shielded. • If the upper feed roll shaft does not have a ground spring, install P/N 1368036. 3. Intermittently low voltages. Check for ac and all dc voltages and short circuits on the main and sub logic boards. <ol style="list-style-type: none"> a. Check the customer's outlet voltage and ensure that it is within tolerance. b. Check the continuity of the power cord. c. Disconnect the power supply cable from the connectors CN11 on the main logic board and CN1 on the sub logic board. Turn the printer power on and check all dc output voltages at CP11 and CP1. <p>Ensure the output voltages are:</p> <p>CP11-1 (+26 V dc $\pm 10\%$) & CP11-2 (GND) CP11-3 (+5 V dc $\pm 5\%$) & CP11-4 (Signal GND) CP 1-1 (+26 V dc $\pm 10\%$) & CP1-2 (GND) CP 1-3 (+5 V dc $\pm 5\%$) & CP1-4 (Signal GND)</p> <p>If the voltages are not correct, replace the Power Supply Unit. If the failure remains, replace the main logic board and sub logic board.</p> <p>Note: When replacing the main logic board, always reset the bidirectional print adjustment. Refer to "Bidirectional Print Adjustment" on page 4-5.</p>

	FRU/Symptom	Action
2	Machine power sometimes turns off.	<p>The cause of this problem may be that the power circuit is failing, or the wiring is intermittently open. Check the following in sequence:</p> <ol style="list-style-type: none"> 1. Check the customer's outlet voltage and be sure it is within tolerance. 2. Check the continuity of the power cord. 3. Disconnect the power supply cable from the connectors CN11 on the main logic board and CN1 on the sub logic board. Turn the printer power on and check all dc output voltages at CP11 and CP1. Be sure the output voltages are as follows: CP11-1 (+26 V dc $\pm 10\%$) & CP11-2 (GND) CP11-3 (+5 V dc $\pm 5\%$) & CP11-4 (Signal GND) CP 1-1 (+26 V dc $\pm 10\%$) & CP1-2 (GND) CP 1-3 (+5 V dc $\pm 5\%$) & CP1-4 (Signal GND) <p>If one of the voltages is 0, go to the “Power Service Check” on page 2-32. If the voltages are not 0 but are incorrect, replace the power supply unit.</p>
3	Intermittently poor print quality.	<p>Do the following:</p> <ul style="list-style-type: none"> • Remove paper jams from the paper path. • Clean all feed roller surfaces. • Clean the ribbon shield and printhead. • Clean the platen surface. • Install the ribbon cartridge correctly. • If the ribbon end of life has been reached, have the customer replace the ribbon cartridge.

	FRU/Symptom	Action
4	If the prior suggestions have not corrected the problem.	<p>The service check has not defined the failure, or the machine is having intermittent failures. The following may cause undefined or intermittent failures:</p> <ol style="list-style-type: none"> 1. Customer's outlet voltage. Be sure that it is within the tolerance. 2. Loose connector pins or keys that fail to contact. Check the following: <ol style="list-style-type: none"> a. Reconnect the connectors of all FRUs and printer interface cables. b. Check the continuity of the line cord. 3. Electrical noise. Check the following: <ol style="list-style-type: none"> a. Power supply ground. b. Machine frame ground. c. Printer interface cable is grounded or shielded. 4. Undefined data in customer applications. Check the baud rate at the controller. Check that the printer interface cable matches the printer.
5	Problem occurs only in specific customer applications.	<p>Perform the Trace Print (hexadecimal printing) by the following procedure and check the data streams.</p> <ol style="list-style-type: none"> 1. Turn the power off. 2. Turn the power on while pressing and holding Alt. 3. Have the customer print the failing job. 4. To stop printing, turn the power switch off. <p>If the failure still occurs, replace the main logic board. Be sure to reset the bidirectional print adjustment, refer to the "Bidirectional Print Adjustment" on page 4-5.</p>

No Print or Abnormal Print Service Check

	FRU/Function	Action
1	Main Logic Board	<p>If the Print Test does not complete correctly, do the following:</p> <ul style="list-style-type: none">• Replace the main logic board.• Reset the bidirectional print adjustment. Refer to “Bidirectional Print Adjustment” on page 4-5.
2	Interface Cable	Check the connection and continuity of the interface cable.
3	Emulation Mode	Enter the Setup Menu and make sure the printer is in the correct emulation mode for the computer, either IBM or Epson.
4	Serial Interface Adapter	<p>If the serial interface adapter is installed, make sure the dip switches match the computer settings.</p> <ul style="list-style-type: none">• Make sure the serial adapter power cable, if present, is securely connected to the printer power connector CN5.• On newer models, make sure the serial interface adapter’s power LED is on when printer power is on. <p>Run the “Serial Interface Adapter Print Test” on page 3-6. If the test is not successful replace the serial interface adapter.</p> <p>If no defect is found, the printer and serial interface adapter are working correctly. The problem may be with the interface cable, the computer, the printer driver, or the specific job being sent.</p>

Operator Panel Service Check

Note: If the Op-Panel Asm is locked, only the **Start/Stop, Form Feed, Alt + Tear Off** and **Alt + Park/Load** buttons are active. Model 2 and 3 printers have a “Lock” LED to indicate that the operator panel is locked. To unlock the operator panel, turn the printer off and then on while pressing Micro \uparrow and Micro \downarrow .

	FRU	Action						
1	Op-Panel Cable Sub Logic Board	<p>Check the connections from the operator panel to the sub logic board and from the sub logic board to the main logic board.</p> <p>Disconnect the operator panel from its cable and make sure +5 V dc is present on the following pins on the cable:</p> <table><tr><td>23XX-001</td><td>23XX-002,003</td></tr><tr><td>CP1-1</td><td>CP1-2</td></tr><tr><td>CP1-7</td><td>CP1-8</td></tr></table> <p>If there is a voltage problem make sure the sub logic board is receiving +5 V dc on CN1-3. Replace the operator panel cable, the sub logic board, or the power cable as necessary.</p>	23XX-001	23XX-002,003	CP1-1	CP1-2	CP1-7	CP1-8
23XX-001	23XX-002,003							
CP1-1	CP1-2							
CP1-7	CP1-8							

	FRU	Action																				
2	Short Flexible Cable	<p>Disconnect the short flexible cable from the main logic board.</p> <p>Check the continuity of the operator panel signal lines between the end of the short flexible cable and the operator panel connector on the sub logic board.</p> <table border="0"> <tr> <td>238X-001</td> <td>238X-002,003</td> </tr> <tr> <td>CP3-4 & CN8-5</td> <td>CP3-4 & CN8-2</td> </tr> <tr> <td>CP3-3 & CN8-6</td> <td>CP3-3 & CN8-4</td> </tr> <tr> <td>CP3-2 & CN8-4</td> <td>CP3-2 & CN8-8</td> </tr> <tr> <td>CP3-1 & CN8-8</td> <td>CP3-1 & CN8-6</td> </tr> </table> <table border="0"> <tr> <td>239X-001</td> <td>239X-002,003</td> </tr> <tr> <td>CP3-4 & CN7-5</td> <td>CP3-4 & CN7-2</td> </tr> <tr> <td>CP3-3 & CN7-6</td> <td>CP3-3 & CN7-4</td> </tr> <tr> <td>CP3-2 & CN7-4</td> <td>CP3-2 & CN7-8</td> </tr> <tr> <td>CP3-1 & CN7-8</td> <td>CP3-1 & CN7-6</td> </tr> </table> <p>Replace the short flexible cable or the sub logic board as necessary.</p> <p>If there is still a problem, replace the operator panel. If that does not fix the problem, re-install the old operator panel and replace the main logic board. If you replace the main logic board, reset the "Bidirectional Print Adjustment" on page 4-5.</p>	238X-001	238X-002,003	CP3-4 & CN8-5	CP3-4 & CN8-2	CP3-3 & CN8-6	CP3-3 & CN8-4	CP3-2 & CN8-4	CP3-2 & CN8-8	CP3-1 & CN8-8	CP3-1 & CN8-6	239X-001	239X-002,003	CP3-4 & CN7-5	CP3-4 & CN7-2	CP3-3 & CN7-6	CP3-3 & CN7-4	CP3-2 & CN7-4	CP3-2 & CN7-8	CP3-1 & CN7-8	CP3-1 & CN7-6
238X-001	238X-002,003																					
CP3-4 & CN8-5	CP3-4 & CN8-2																					
CP3-3 & CN8-6	CP3-3 & CN8-4																					
CP3-2 & CN8-4	CP3-2 & CN8-8																					
CP3-1 & CN8-8	CP3-1 & CN8-6																					
239X-001	239X-002,003																					
CP3-4 & CN7-5	CP3-4 & CN7-2																					
CP3-3 & CN7-6	CP3-3 & CN7-4																					
CP3-2 & CN7-4	CP3-2 & CN7-8																					
CP3-1 & CN7-8	CP3-1 & CN7-6																					

Paper Empty Sensor Service Check

Note: 23XX-001 machines have a single paper sensor that serves as a paper empty sensor and also determines the top of form setting.

23XX-002 and 23XX-003 machines have two sensors:

- The left sensor is paper empty.
- The right sensor is Top of Form.

	FRU	Action
1	Paper Empty Sensor	<p>With no paper in the printer, the tractor in the push position, and the paper select lever set to continuous forms, press Alt+Park/Load; the gear train should turn forward (to try to load paper).</p> <p>Activate the paper empty sensor with a screwdriver and press Alt+Park/Load again; the gear train should turn backward (to try to park paper).</p> <p>Measure the voltage between CN7-2 (paper empty signal) and CN7-3 (GND) on the main logic board. There should be 0 V dc when there is paper in the printer, and +5 V dc when there is no paper in the printer.</p> <p>Make sure the sensor and its actuator are properly installed and undamaged. Correct the problem or replace the sensor.</p>
2	Main Logic Board	<p>If the ASF is being used, it is normal for the Paper Out LED not to blink when there is no paper in the printer. Do the following:</p> <ul style="list-style-type: none"> • Enter the Setup Menu. • Make sure the ASF setting is off unless the ASF is installed. • If the sensor and the ASF setting are OK, replace the main logic board. • Reset the "Bidirectional Print Adjustment" on page 4-5.

Paper Feed Service Check

Note: If the problem is frequent jams or paper creases, verify that the paper is neither very thick nor very thin. If necessary refer the customer to the User's Guide for specifications of acceptable papers. On 23XX-001 printers check for equal gap between the lower feed rollers and lower pinch rollers. If the gap is smaller on the left, install Shim Kit, P/N 1368067.

If the paper does not stop in the correct location, refer to the **"Paper Empty Sensor Service Check"** on page 2-26 and the **"Top of Forms Problem Service Check"** on page 2-39.

	FRU / Symptom	Action
1	Auto Sheet Feeder	<p>If the Auto Sheet Feeder is installed, remove it. Enter the Setup Menu and reset "ASF" to off. Verify that the machine works correctly without the ASF installed.</p> <p>If the printer fails only with the Auto Sheet Feeder installed, refer to the "Auto Sheet Feeder (ASF) Service Check" on page 2-15.</p>
2	Gear Train	<p>Remove all paper from the machine.</p> <p>Press Form Feed several times and examine all rotating parts to find the problem.</p> <p>For better visibility, remove the covers and reconnect the operator panel to the sub logic board.</p> <p>The upper and lower feed rollers and the upper and lower pinch rollers should all be clean and in good condition, and should all rotate during Form Feed.</p> <p>To turn the gear train manually on a 23XX-002 or 23XX-003, turn the right end of the lower feed roller shaft with a 6 mm wrench.</p>

	FRU / Symptom	Action
3	Paper Selector Lever	<p>Make sure the selector lever alternately engages and disengages the tractor gear and the ASF drive gear.</p> <p>Check the operation of the following parts as you move the paper select lever:</p> <ul style="list-style-type: none"> • The tractor gear engages correctly in the continuous forms position. • The tractor belts are in good condition and rotate correctly. • The pinch roller shafts move downward as the lever moves to the cut sheet position. • The paper separator moves upward as the lever moves to the cut sheet position.
4	Operator Panel	<p>If paper does not move at all, verify that the Form Feed button is working as follows:</p> <p>With the tractor in the push position, power off, power on, then press Alt/Load. The carrier should move to the center of the platen. If it does not, go to the “Operator Panel Service Check” on page 2-24.</p>
5	Paper Feed Motor	<p>Disconnect the paper feed motor cable CN10 from the main logic board. No pin should have continuity to ground. The resistances should be as follows:</p> <p>23XX-001, 002 = 21 to 24 ohms.</p> <p>CP10-1 to CP10-5 CP10-1 to CP10-6 CP10-2 to CP10-5 CP10-2 to CP10-6 CP10-3 to CP10-5 CP10-3 to CP10-6 CP10-4 to CP10-5 CP10-4 to CP10-6</p> <p>23XX-003 = 8 to 9 ohms.</p> <p>CP10-1 to CP10-5 CP10-2 to CP10-5 CP10-3 to CP10-5 CP10-4 to CP10-5</p>

	FRU / Symptom	Action
6	Paper Select Sensor	<p>Remove all paper from the printer and place the tractor in the push position.</p> <p>Press Form Feed and time how long the gear train rotates.</p> <ul style="list-style-type: none"> • With the paper select lever in the cut sheet position (sensor open) the gear train should rotate for less than 2 seconds; • With the lever in the continuous forms position (sensor closed), the gear train should rotate for more than 3 seconds. <p>If the printer does not do this, inspect the sensor to make sure it is being opened and closed by the paper separator.</p> <p>Disconnect CN5 from the sub logic board and measure the paper selector sensor resistance from CP5-1 to CP5-2.</p> <p>Replace the sensor if the resistance does not change from zero to infinite as the paper select lever is moved.</p>
7	Pull Tractor Sensor	<p>If the pull tractor sensor has failed to close, Park/Load and Auto Tear Off will not work when using push tractors.</p> <p>If the sensor has failed to open, Park/Load will try to park paper when using pull tractors, but the paper will feed all the way out of the tractors and cannot reload. Refer to the “Pull Tractor Sensor Service Check” on page 2-38.</p>
8	Main Logic Board	<p>If no other problem is found replace the main logic board. Reset the “Bidirectional Print Adjustment” on page 4-5.</p>

Paper Select Sensor Service Check

If form feed length is off by about 1 inch (25 mm), enter Setup Mode and verify that the form length setting is correct. See the Setup Mode and Switch Settings section.

	FRU	Action								
1	Paper Select Sensor	<p>Remove all paper from the printer and place the tractor in the push position. Make sure the Auto Sheet Feed (ASF) is set to OFF in the Setup Mode.</p> <p>Press Form Feed and time how long the gear train rotates.</p> <p>With the paper select lever in the cut sheet position (sensor open) the gear train should rotate for less than 2 seconds; with the lever in the continuous forms position (sensor closed), the gear train should rotate for more than 3 seconds. If the printer does not do this, inspect the sensor to make sure it is being opened and closed by the paper separator.</p> <p>Disconnect CN5 from the sub logic board and measure the paper selector sensor resistance from CP5-1 to CP5-2.</p> <p>Replace the sensor if the resistance does not change from zero to infinite as the paper select lever is moved from cut sheet to continuous forms.</p> <p>If the sensor is good but the gear train does not run the right length of time, set the head gap to position 1 and disconnect the short flexible cable from CN3 on the main logic board. Check the continuity between CP3-6 (paper select sensor) and GND while actuating the paper select lever.</p> <table data-bbox="452 1274 909 1380"> <thead> <tr> <th>Cut Sheet</th> <th>Continuous Forms</th> </tr> </thead> <tbody> <tr> <td><u>23XX-001</u></td> <td><u>23XX-002</u></td> </tr> <tr> <td>1K ± 0.5K ohms</td> <td>0K ± 0.5K ohms</td> </tr> <tr> <td>12K ± 0.5K ohms</td> <td>3.5K ± 0.5K ohms</td> </tr> </tbody> </table> <p>If the resistance is correct, replace the main logic board. If the resistance is incorrect, replace the sub logic board.</p>	Cut Sheet	Continuous Forms	<u>23XX-001</u>	<u>23XX-002</u>	1K ± 0.5K ohms	0K ± 0.5K ohms	12K ± 0.5K ohms	3.5K ± 0.5K ohms
Cut Sheet	Continuous Forms									
<u>23XX-001</u>	<u>23XX-002</u>									
1K ± 0.5K ohms	0K ± 0.5K ohms									
12K ± 0.5K ohms	3.5K ± 0.5K ohms									

	FRU	Action
2	Pull Tractor Sensor	A failed pull tractor sensor can cause Alt + Park/Load not to function. With the tractor in the push position, press Alt+Park/Load several times while alternately holding down and releasing the left pull tractor actuator. The paper should not park or load when the pull tractor actuator is held down. If it does, go to the "Pull Tractor Sensor Service Check" on page 2-38.

POST Service Check

	FRU	Action
1	Power LED	If the power LED is not on, go to the "Power Service Check" on page 2-32.
2	Cables	<p>A faulty interface cable can cause POST errors. Disconnect the interface cable from the printer and turn the printer off and then on.</p> <p>Check the connections of the short flexible cable and the power cable to the main logic board and sub logic board.</p> <p>Check the condition and continuity of the operator panel cable.</p>
3	Operator Panel	If no problem is found, the problem may be in either the operator panel or the main logic board. Replace the operator panel and retest the printer.
4	Main Logic Board	<p>Replace the main logic board if necessary.</p> <p>Reset the bidirectional print adjustment; refer to "Bidirectional Print Adjustment" on page 4-5.</p>

Power Service Check

If the symptom is that the Power light varies in intensity, make sure the upper feed roll shaft has the ground spring. If it does not, install ESD Kit P/N 1368036.

	FRU	Action
1	Power Supply	<p>If the carrier does not move to the left after turning the printer off and then on, do the following:</p> <ul style="list-style-type: none"> • Make sure the line cord voltage to the power supply is correct. • Make sure the power supply outputs are +5 V dc at CN1-2 and +26 V dc at CN1-4. If the voltage is incorrect, check the internal fuses before replacing the power supply. Generally if F3 is blown it is due to a short in the printhead; replace the printhead and the fuse before powering on again. • Check for +5 V dc at main logic board CN11-3 and sub logic board CN1-3, and for +26 V dc at main logic board CN11-1 and sub logic board CN1-1. • Make sure the short flexible cable is undamaged and correctly installed.
2	Sub Logic Board	<p>If the carrier moves to the left after turning the printer off and then on, do the following:</p> <ul style="list-style-type: none"> • Move the carrier to the right and turn power on. The carrier should move to the left. The power LED should be on steady whenever the printer is on. If the carrier moves to the left during after turning the printer off and then on, but the power LED is not on steady: Make sure the sub logic board is receiving voltage by checking for +5 V dc at sub logic board CN1-3. • If no voltage or power cable problem is found, make sure there is +5 V on pins 3 and 9 of the sub logic board connector for the operator panel cable. If the voltage is incorrect replace the sub logic board.

	FRU	Action
3	Op-Panel Op-Panel Cable	If there is still a power LED problem, check the operator panel cable continuity and replace the cable or the operator panel.
4	Carrier Motor	Disconnect the carrier motor from main logic board CN9 and turn the printer off and then on. If the power LED lights correctly only with the carrier motor disconnected, replace the carrier motor.
5	Paper Feed Motor	Disconnect the paper feed motor from main logic board CN10 and turn the printer off and then on. If the power LED lights correctly only with the paper feed motor disconnected, replace the paper feed motor.
6	Printhead Printhead Cables	<p>Disconnect the printhead cable from the sub logic board and turn the printer on. If the power LED lights correctly only with the printhead cables disconnected from the sub logic board, there is a short in the printhead or printhead cables.</p> <p>Disconnect the printhead cable from the sub logic board and make sure none of the leads on the cable are shorted to ground.</p>
7	Main Logic Board	<p>If no problem is found with other components but the printer still has a power problem, replace the main logic board.</p> <p>Reset the bidirectional print adjustment; refer to “Bidirectional Print Adjustment” on page 4-5.</p>

Print Speed Service Check

Reduced speed while printing the top 2 inch (51 mm) of a job is normal; for Model 003 printers, the slow down can be eliminated by entering **Setup Mode** and disabling **TOF Read**. The speed of the 23XX printers varies with the font, forms thickness setting and printhead temperature. Graphics output may print slowly due to data throughput limitations. Thermal sensing is built into the printhead on 239X printers and protects the printhead from overheating.

Depending on the job content, thermal slowdown may occur after 5 to 10 minutes of continuous operation on 239X-001 printers and after 10 to 20 minutes on 239X-002, 003 printers.

Print slowdown modes are as follows:

	Thermal Slowdown	Forms Thickness Slowdown
238X-001	No	26% speed reduction at Forms Thickness 7. Head Gap Sensor contains one switch.
239X-001	Yes	No Forms Thickness speed reduction. No Head Gap Sensor.
238X-002 238X-003	No	Reduced print wire force at Forms Thickness 1. 23% speed reduction at Forms Thickness 4 through 7. Head Gap Sensor Assembly contains two switches.
239X-002 239X-003	Yes	Reduced print wire force at Forms Thickness 1. 20% speed reductions at Forms Thickness 4 through 7. Head Gap Sensor Assembly contains two switches.

	FRU	Action
1	Head Gap Sensor 23XX-001	<p>Check the function of the head gap sensor by moving the forms thickness lever from 6 to 7 and back while printing the Demo Page Alt + Demo. Print speed is reset at the beginning of each line; listen for the printer to slow down in position 7.</p> <p>Disconnect the head gap sensor from connector CN3 on the sub logic board. Check the resistance of the sensor while moving the forms thickness lever. Resistance should be 0 ohms at forms thickness position 7 and infinite at positions 1 through 6.</p>
2	Head Gap Sensor 23XX-002 23XX-003	<p>Check the function of the head gap sensor by turning the power on with the Alt + Macro buttons pressed.</p> <ul style="list-style-type: none"> • With the forms thickness lever at 1, Macro LED 1 will light. • With the forms thickness lever at 2 and 3, Macro LED 2 will light. • With the forms thickness lever at 4 through 7, Macro LED 3 will light. <p>Disconnect the head gap sensor asm from connector CN3 on the sub logic board. Check the resistance of the sensor while moving the forms thickness lever. Resistance should be 0 ohms at position 1 and infinite at positions 2 through 7.</p> <p>Disconnect the head gap sensor asm from connector CN4 on the sub logic board. Check the resistance of the sensor while moving the forms thickness lever. Resistance should be 0 ohms at positions 1 through 3 and infinite at positions 4 through 7.</p>

Printhead Service Check

	FRU	Action
1	Printhead Cables Printhead	<p>If the problem is missing or extra dots or lines, do the following:</p> <ul style="list-style-type: none">• Check the continuity and connection of the printhead cables and the short flexible cable.• Make sure the voltages to the sub logic board are correct. <p>If dots are missing:</p> <ul style="list-style-type: none">• Perform the print test to determine which wire is not firing.• Remove the printhead and check the printhead resistance according to the following table. Make sure no pins have continuity to the printhead housing.

	FRU	Action
1	Printhead	<p>Continuity Table The correct resistance is: 2.8 to 3.8 ohms (238X) or 7 to 15 ohms (239X).</p> <p>238X CP9-10 & CP9-12 (Dot1) CP9- 6 & CP9- 4 (Dot2) CP9-17 & CP9-14 (Dot3) CP9- 7 & CP9- 3 (Dot4) CP9-15 & CP9-11 (Dot5) CP9- 1 & CP9- 5 (Dot6) CP9-18 & CP9-13 (Dot7) CP9- 2 & CP9- 8 (Dot8) CP9-16 & CP9- 9 (Dot9)</p> <p>239X CP8-10 & CP8-13 (Dot1) CP8- 8 & CP8- 7 (Dot2) CP8-12 & CP8-13 (Dot3) CP8- 6 & CP8- 7 (Dot4) CP8-14 & CP8-11 (Dot5) CP8- 4 & CP8- 7 (Dot6) CP8-16 & CP8-11 (Dot7) CP8- 2 & CP8- 9 (Dot8) CP8-18 & CP8-11 (Dot9) CP8- 1 & CP8- 9 (Dot10) CP8-17 & CP9-10 (Dot11) CP8- 3 & CP8- 9 (Dot12) CP8-15 & CP9-10 (Dot13) CP8- 5 & CP9- 8 (Dot14) CP9-16 & CP9-12 (Dot15) CP9- 4 & CP9- 8 (Dot16) CP9-17 & CP9-12 (Dot17) CP9- 2 & CP9- 8 (Dot18) CP9-15 & CP9-12 (Dot19) CP9- 1 & CP9- 6 (Dot20) CP9-13 & CP9-14 (Dot21) CP9- 3 & CP9- 6 (Dot22) CP9-11 & CP9-14 (Dot23) CP9- 5 & CP9- 6 (Dot24)</p> <p>If the problem is not missing or extra dots or lines, do the following:</p> <ul style="list-style-type: none"> • Make sure the printhead is securely installed in the carrier. • Perform the Printhead-to-Platen Gap adjustment.

	FRU	Action
2	Carrier Shaft Carrier Unit Platen Assembly Printhead Nose Ribbon Guide	Check and replace worn or damaged parts.

Pull Tractor Sensor Service Check

Note: The pull tractor sensor detects the tractor in the pull position and disables park/load and auto tear-off. A failed sensor may prevent park/load from functioning with the tractor in the push position.

	FRU	Action
1	Pull Tractor Sensor	<p>With the tractor in the push position, press Alt+Park/Load several times while alternately holding down and releasing the left pull tractor actuator. The paper should park and load when the actuator is not held down, and should not park or load when the pull tractor actuator is held down.</p> <p>If the paper does not move correctly:</p> <ul style="list-style-type: none"> • Disconnect CN4 from the main logic board. • There should be 0 ohms from CP4-1 to CP4-2 when the left pull tractor actuator is pressed, and infinite resistance when the actuator is not pressed. • Replace the sensor if necessary. <p>If the sensor is good but the paper still does not move correctly:</p> <ul style="list-style-type: none"> • Replace the main logic board. • Reset the Bidirectional Alignment, see "Bidirectional Print Adjustment" on page 4-5.

Top of Forms Problem Service Check

Note: This service check applies to the 23XX-002 and 23XX-003 printers only. 23XX-001 machines have a single paper sensor that serves as a paper empty sensor and also determines the top of form setting. For top of forms problems on 23XX-001 printers, refer to the **“Paper Empty Sensor Service Check”** on page 2-26.

23XX-002 and 23XX-003 machines have two sensors:

- The left sensor is paper empty.
- The right sensor is top of form.

	FRU	Action
1	Top of Form Sensor	Check that the top of form sensor and its flag are properly installed and are undamaged.
2	Main Logic Board	<p>Remove the paper and set the paper select lever to the cut sheet position and turn the power on.</p> <p>Measure the voltage between main logic board CN8-2 (TOF signal) and CN8-3 (GND).</p> <ul style="list-style-type: none">• When there is paper in the printer the voltage should be 0 V dc.• When there is no paper in the printer the voltage should be 5 V dc. <p>Replace the sensor if the voltage is incorrect.</p> <p>Replace the main logic board if the voltage is correct and there is still a problem.</p> <p>Reset the “Bidirectional Print Adjustment” on page 4-5.</p>

Tractor 2 Service Check

Note: This option can be used only on 23XX-003 printers.

The Tractor 2 in-place sensor opens during installation, when its actuator touches the printer cover. The home sensor detects the position of the slider.

- When Tractor 2 is selected the motor-driven Tractor 2 slider pushes the printer sub slider cam lever to engage the printer gear train which drives the Tractor 2 tractors.
- When the Tractor 2 is deselected, the motor retracts the slider, disengaging the Tractor 2 gear drive and reengaging the printer tractors.

10 Beeps and Blinking Ready, Paper, Font and Pitch LEDs

Tractor 2 home sensor never made after turning the printer off and then on, or made at the wrong time.

(The same error indication is used for carrier home failure.)

	FRU	Action
1	Tractor 2 Home Sensor	<p>Remove the Tractor 2 and turn the printer off and then on again to determine if the fault is in the printer or Tractor 2.</p> <p>If the gear teeth chatter just before the beeps, replace the home sensor.</p>
2	Main Logic Board	<p>Remove Tractor 2 from the printer but leave the cable connected. Make sure the slider (the black plastic piece just above the right cover) moves after turning the printer off and then on.</p> <p>If the slider does not move after turning the printer off and then on:</p> <ul style="list-style-type: none"> • Make sure the slider and gear train are properly connected and move freely with the power off. • Make sure the Tractor 2 board is receiving: <ul style="list-style-type: none"> +26 V dc on CN1-1 and + 5 V dc on CN1-5. <p>If not, check the cable connection and the voltages at main logic board CN6-1. The upper right pin at CN6 is pin 1 (+26 V dc) and the pin just beneath it is pin 5 (+5 V dc).</p> <p>If these voltages are not present replace the main logic board.</p>
3	Tractor 2 Motor Board /Cable Asm	<p>Check the resistances of the Tractor 2 motor windings: there should be 101 ± 5 ohms between pins: 1 and 5, 3 and 5, 2 and 6 and 4 and 6. If the motor is good, replace the board/cable assembly.</p> <p>For information on the Tractor 2 cable connectors, see "Tractor 2 Cable Connectors" on page 5-4.</p>

3 Beeps and Tractor 2 LED blinks 3 times

Tractor 2 selected from operator panel but printer does not detect Tractor 2 or detects that the Tractor 2 mechanism is not installed.

	FRU	Action
1	Tractor 2 Board/Cable Asm.	<p>Check the Tractor 2 in-place sensor or the cable connection.</p> <p>The in-place sensor actuator extends through the Tractor 2 cover and rests on the printer cover when Tractor 2 is installed.</p> <p>Remove the Tractor 2 cover and make sure the in-place sensor opens when the Tractor 2 is installed. The voltage at Tractor 2 CN1-13 should be +5 V dc with the sensor open and 0 with it closed.</p> <p>Replace the Tractor 2 board/cable asm if the sensor signal is wrong.</p> <p>For information on the Tractor 2 cable connectors, see "Tractor 2 Cable Connectors" on page 5-4.</p>
2	Main Logic Board	<p>Check the cable connection from Tractor 2 to the printer.</p> <p>If possible, try the Tractor 2 with another printer to determine if the problem is the Tractor 2 board/cable assembly or the printer main logic board.</p>

Paper Feed Problems

	FRU	Action
1	Tractor 2	<p>On the printer, make sure the gear that drives Tractor 2 turns freely when the lever is not pressed, but remain still when the lever is pressed.</p> <p>Remove Tractor 2 from the printer and remove all paper. With the paper select lever in the continuous forms position, press Line Feed; the tractors should rotate.</p> <p>Press the sub slider cam lever below the ASF/ Tractor 2 drive gear and press Line Feed again; the tractors should not rotate but the drive gear should.</p> <p>Check the condition of the pin feed belts. With the power off, make sure the slider does not bind.</p> <p><u>Verify:</u></p> <ul style="list-style-type: none"> • When the slider is to the rear, the white gear drives the tractors; • When the slider is to the front the gear and tractors are not connected. <p>Remove the Tractor 2 cover and reinstall Tractor 2 in the printer (if necessary remove the printer covers also). Note that the small idler gear just below the slider is held in place by the cover; with the cover removed it will tend to move off the stud. Also note that when operating the Tractor 2 with the printer cover removed, the Tractor 2 in-place sensor must be held open.</p> <p>Turn the printer on and look for mechanical problems.</p> <p>For information on the Tractor 2 cable connectors, see “Tractor 2 Cable Connectors” on page 5-4.</p>

3. Diagnostic Aids

The printer contains self tests to help find and solve problems. You need not connect the printer to a computer or terminal to run these tests.

Types of self tests are as follows:

- Power-On Self Test (POST)
- Print Test
- Hex Dump Mode (a computer or terminal is needed)
- Serial Interface Adapter Print Test

The following are special machine modes that run when the printer is turned off and then back on:

Turn the printer on while Pressing:	Does This:
Line Feed	Print test with sample fonts.
Alt	Sets printer in Hex Dump mode.
Micro↑ & Micro↓	Disables/Enables Operator Panel Lockout Mode.
Alt + Tear Off (with printhead at extreme left)	Resets to World Trade default paper sizes.
Alt + Setup (with printhead at extreme left)	Resets to US default paper sizes.
Alt + Macro (23XX-002, 003)	Head Gap Sensor Test: Macro LEDs indicate sensor position.

Power-On Self Test (POST)

The following tests are automatically performed when the printer is turned on.

- LEDs Test (Checks that the LEDs on the operator panel work. The LEDs turn on and off after the printer is turned on then all LEDs turn on for a few seconds.)
- RAM Test (Checks that the CPU can write/read the RAM.)
- Font ROM/Microcode Sum Test (Checks that the ROM data is correct.)
- Timer/Interrupt Controller Test (Checks that this function works.)
- NVRAM Test (Checks that the NVRAM data is correct.)
- Switch Scan Test (Checks the buttons on operator panel.)
- Carrier Initialization (Carrier moves to the left to activate the home position sensor, then moves to the first print position.)
- Feed Initialization (Form feed motor rotates forward, then backward.)

If any errors occur during the POST tests, a combination of blinking LEDs will indicate which test failed. See “Start” on page 2-1.

Print Test

The print test can help you test and troubleshoot the printer. To start the print test, do the following:

1. Paper must be at the print position; test does not print if paper is parked.
2. Press and hold **Line Feed** and then turn the printer on.
3. Release **Line Feed** when the printing starts.
4. To interrupt the printer test:
 - Press **Start/Stop**. The test stops after a complete line of characters has printed.
 - Press **Start/Stop** to continue the test sample.
5. To stop the printer test, turn the printer off.

The printout should be similar to the print test samples shown on page 3-4.

If the printout is not like the sample, go to “Start” on page 2-1.

Note that the short horizontal lines at the top of the sample are a test of each printhead wire numbered in sequence from top to bottom.

Service Notes

- Before starting the 2380 and 2390 print test, be sure letter size paper is loaded in the machine.
- Before starting the 2381 and 2391 print test, be sure wide paper is loaded in the machine, and that the right margin is set to 13.6 inches.
- After you complete any repairs, run the print test several times to be sure the printer is operating correctly.

Print Test Sample (9 wire)

NO. DVT2.311A3209 © Copyright Lexmark,

1 — 2 — 3 — 4 — 5 — 6 —

FastDraft

0123456789 ; <=> ? @ ABCDEFGHIJ KLMNOPQRST
xyz < |) ^ ¨ 0 1 2 3 4 5 6 7 8 9 : ; <=> ? @ ABCDEFGHIJ KLMNOPQRST
123456789 ; <=> ? @ ABCDEFGHIJ KLMNOPQRSTU

Draft

0123456789 ; <=> ? @ ABCDEFGHIJ KLMNOPQRST
xyz < |) ^ ¨ 0 1 2 3 4 5 6 7 8 9 : ; <=> ? @ ABCDEFGHIJ KLMNOPQRST
123456789 ; <=> ? @ ABCDEFGHIJ KLMNOPQRSTU

Gothic

0123456789 ; <=> ? @ ABCDEFGHIJ KLMNOPQRST
xyz < |) ^ ¨ 0 1 2 3 4 5 6 7 8 9 : ; <=> ? @ ABCDEFGHIJ KLMNOPQRST
123456789 ; <=> ? @ ABCDEFGHIJ KLMNOPQRSTU

Courier

Print Test Sample (24 wire)

NO.070 1332983 © Copyright Lexmark, 1

1 — 2 — 3 — 4 — 5 — 6 —
13 — 14 — 15 — 16 — 17 — 18 —

0123456789 ; <=> ? @ ABCDEFGHIJ KLMNOPQRST
xyz < |) ^ ¨ 0 1 2 3 4 5 6 7 8 9 : ; <=> ? @ ABCDEFGHIJ KLMNOPQRST
123456789 ; <=> ? @ ABCDEFGHIJ KLMNOPQRSTU

32 11 ABCDEFGHIJKLMNOPQRSTUVWXYZabcdefghijklmnopqrstuvwxyz
96 11 ABCDEFGHIJKLMNOPQRSTUVWXYZabcdefghijklmnopqrstuvwxyz
160 11 ABCDEFGHIJKLMNOPQRSTUVWXYZabcdefghijklmnopqrstuvwxyz
160 12 ABCDEFGHIJKLMNOPQRSTUVWXYZabcdefghijklmnopqrstuvwxyz
160 36 ABCDEFGHIJKLMNOPQRSTUVWXYZabcdefghijklmnopqrstuvwxyz
160 25 ABCDEFGHIJKLMNOPQRSTUVWXYZabcdefghijklmnopqrstuvwxyz
160 5 ABCDEFGHIJKLMNOPQRSTUVWXYZabcdefghijklmnopqrstuvwxyz

Hex Dump Mode

The hex dump mode can help the user test and troubleshoot programs. You can use the hex dump procedure to get a hexadecimal printout of the data stream sent to the printer. All data, including both control and character data, print in hexadecimal instead of ASCII.

To activate hex dump mode:

1. Press and hold **Alt** and then turn the printer on.
2. After a few seconds, release **Alt**.
3. Start your application program. Be sure the printout is similar to the hex dump sample shown. Two hexadecimal digits, followed by a space, are printed for each byte of data sent to the printer.
4. The printer continues to print in hexadecimal until you turn the printer off.

Hex Dump Mode Sample

```

20 20 20 30 20 20 40 20 20 50 20 20 60 20 20 70 20 20 80 20 20 90 20 20
20 00 20 20 E0 20 20 F0 00 20 61 20 20 71 20 20 81 20 20
91 20 20 A1 20 20 B1 20 20 C1 20 20 D1 20 20 E1 20 20 F1 20 20 0A
20 20 62 20 20 72 20 20 82 20 20 92 20 20 A2 20 20 B2 20 20 C2 20 20
0A 23 20 20 33 20 20 43 20 20 53 20 20 63 20 20 73 20 20 83 20 20 C3
20 20 03 20 20 E3 20 20 F3 20 20 04 20 20 14 20 20 24 20 20 34 20 20
20 94 20 20 A4 20 20 B4 20 20 C4 20 20 D4 20 20 E4 20 20 F4 20 20 05
55 20 20 65 20 20 75 20 20 85 20 20 95 20 20 A5 20 20 B5 20 20 C5 20 20
0A 0A 26 20 20 36 20 20 46 20 20 56 20 20 66 20 20 76 20 20 86 20 20
C6 20 20 D6 20 20 E6 20 20 F6 20 20 07 20 20 17 20 20 27 20 20 37 20 20
20 20 97 20 20 A7 20 20 B7 20 20 C7 20 20 D7 20 20 E7 20 20 F7 20 20 08
20 59 20 20 69 20 20 79 20 20 89 20 20 99 20 20 A9 20 20 B9 20 20 C9
0D 0A 0A 29 20 20 39 20 20 49 20 20 59 20 20 69 20 20 79 20 20 89
20 C9 20 20 D9 20 20 E9 20 20 F9 20 20 0A 20 20 1A 20 20 2A 20 20 3A
8A 20 20 9A 20 20 AA 20 20 BA 20 20 CA 20 20 DA 20 20 EA 20 20 FA 20 20
20 20 58 20 20 68 20 20 78 20 20 88 20 20 98 20 20 A8 20 20 B8 20 20
FB 0D 0A 0A 2C 20 20 3C 20 20 4C 20 20 5C 20 20 6C 20 20 7C 20 20 8C
20 20 CC 20 20 DC 20 20 EC 20 20 FC 20 20 0D 20 20 1D 20 20 2D 20 20
20 8D 20 20 9D 20 20 AD 20 20 BD 20 20 CD 20 20 DD 20 20 0E 20 20 1E
4E 20 20 5E 20 20 6E 20 20 7E 20 20 8E 20 20 9E 20 20 AE 20 20 BE
20 FE 0D 0A 0A 2F 20 20 3F 20 20 4F 20 20 5F 20 20 6F 20 20 7F 20 20
BF 20 20 CF 20 20 DF 20 20 EF 20 20 FF 20 20 00 20 20 01 20 20 02 20 20

```

Serial Interface Adapter Print Test

The serial interface adapter has a switch that enables a test of the connection between the serial interface adapter and the printer main logic board. This generates a short test print containing the serial interface adapter code level and switch settings, and the printer character set.

To run the serial interface test print:

1. Turn the printer off.
2. Turn on serial interface Switch 10.
3. Turn the printer on.

If the printer does not generate a printout, there is a problem with the serial interface adapter or its connection to the printer. Check the switch settings and be sure the serial interface adapter is correctly installed.

When the test is complete, turn off Switch 10.

4. Repair Information

This chapter contains adjustments and removal procedures. Whenever parts are replaced, make sure that all adjustments are correct by running diagnostics procedures and checking adjustments as needed.

Handling ESD-Sensitive Parts

Many electronic products use parts that are known to be sensitive to electrostatic discharge (ESD). To prevent damage to ESD-sensitive parts, follow the instructions below in addition to all the usual precautions, such as turning off power before removing logic boards:

- Keep the ESD-sensitive part in its original shipping container (a special “ESD bag”) until you are ready to install the part into the machine.
- Make the least-possible movements with your body to prevent an increase of static electricity from clothing fibers, carpets, and furniture.
- Put the ESD wrist strap on your wrist. Connect the wrist band to the system ground point. This discharges any static electricity in your body to the machine.
- Hold the ESD-sensitive part by its edge connector shroud (cover); do not touch its pins. If you are removing a pluggable module, use the correct tool.
- Do not place the ESD-sensitive part on the machine cover or on a metal table; if you need to put down the ESD-sensitive part for any reason, first put it into its special bag.
- Machine covers and metal tables are electrical grounds. They increase the risk of damage because they make a discharge path from your body through the ESD-sensitive part. (Large metal objects can be discharge paths without being grounded.)
- Prevent ESD-sensitive parts from touching other personnel. Install machine covers when not working on the machine, and do not put unprotected ESD-sensitive parts on a table.
- Keep all ESD-sensitive parts in a grounded metal cabinet (case).
- Low humidity increases static electricity during cold-weather.

Adjustments

CAUTION: Be sure to unplug the power cord whenever you are working on the printer with one of the covers removed.

Printhead-to-Platen Gap Adjustment

WARNING: To prevent damage to the printhead when this adjustment is made, be sure a gap exists between the printhead and the right end of the platen before you turn the printer on.

Perform the printhead-to-platen gap adjustment after replacing or disassembling any of the following parts:

- Carrier
- Platen
- Pinch Roller (Lower)
- Ribbon Drive Rack Gear
- Side Frame (Left)
- Side Frame (Right)
- Paper Separator
- Feed Roller (Lower)
- Paper Guide.

Note: Make sure the top cover is installed.

1. Turn the printer off.
2. Remove the ribbon access cover.
3. Remove the ribbon cartridge and paper.
4. Set the form thickness lever to position 1.
5. Move the carrier so that it is just to the left of the left upper feed roller, approximately 50 mm (2.0 in.) from the left side frame.
6. Using feeler gauges [1] of 0.35 mm and 0.40 mm (0.014 in. and 0.016 in.), move the left carrier bushing [2] forward or backward until the gap between the printhead [3] and platen [4] is between 0.35 mm - 0.40 mm (0.014 in. - 0.016 in.).

Note: The gap should be wide enough for the 0.35 mm (0.014 in.) feeler gauge to slide in smoothly without catching, but too narrow to insert the 0.40 mm (0.016 in.) feeler gauge.

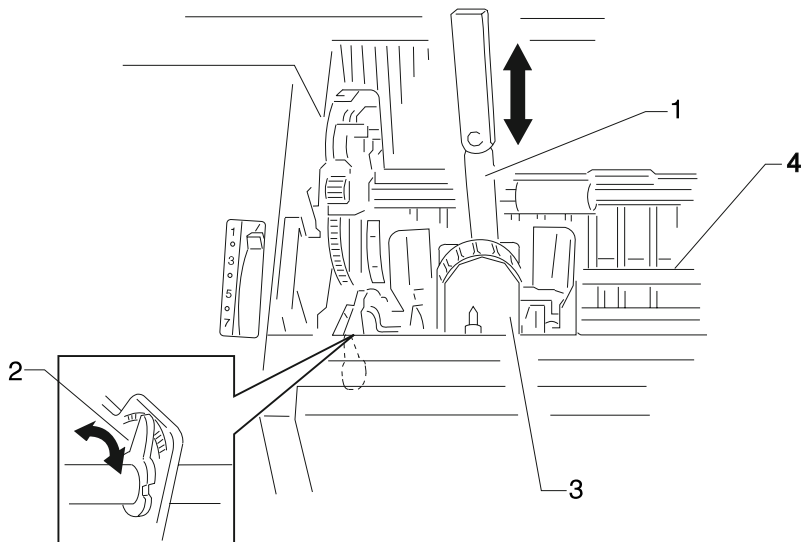

7. Move the carrier so that it is just to the right of the right upper feed roller, approximately 50 mm (2.0 in.) from the right side frame.
8. Using feeler gauges [1] of 0.35 mm and 0.40 mm (0.014 in. and 0.016 in.), move the right carrier bushing [2] forward or backward until the gap between the printhead [3] and platen [4] is between 0.35 mm - 0.40 mm (0.014 in. - 0.016 in.).

Note: The gap should be wide enough for the 0.35 mm (0.014 in.) feeler gauge to slide in smoothly without catching, but too narrow to insert the 0.40 mm (0.016 in.) feeler gauge.

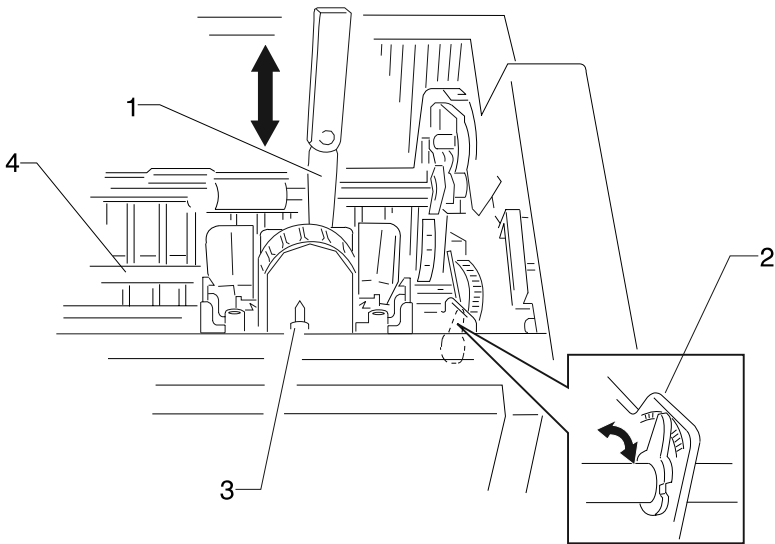

9. Repeat Steps 5 and 6 and readjust the gap if necessary.
10. Repeat Steps 7 and 8 and readjust the gap if necessary.
11. Set the form thickness lever to suit the paper thickness you are using.
12. Install the ribbon cartridge and paper.
13. Install the ribbon access cover.
14. Run the self test and check the density of the printing. Repeat procedure if necessary.

Bidirectional Print Adjustment

After replacing any mechanical part which affects the operation of the main logic board or the carrier, perform the following procedure to adjust the bidirectional print.

Note: This adjustment cannot be completed if the printer runs out of paper, so be sure to use continuous forms.

1. Be sure the ribbon cartridge and continuous forms are installed.
2. Turn the printer on.
3. Press **Alt** and then press **Micro**↑ . The printer enters Setup Mode.
4. Press the Control Options button. (Button varies with model.)
5. Press the Bidirectional Alignment button. (Button varies with model.)
6. Press **Font**. The printer prints out the pattern shown below. The first and third lines are printed from left to right. The second and fourth lines are printed from right to left.

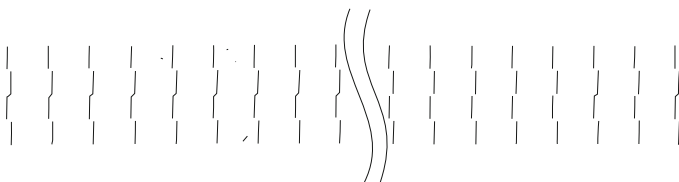

7. Align the second and fourth lines to the first and third lines.
Each time **Micro**↑ is pressed, the second and fourth lines shift toward the left. Each time **Micro**↓ is pressed, the second and fourth lines shift toward the right.
8. Continue adjusting the bidirectional alignment by repeating step 7, until your printout resembles the one shown.

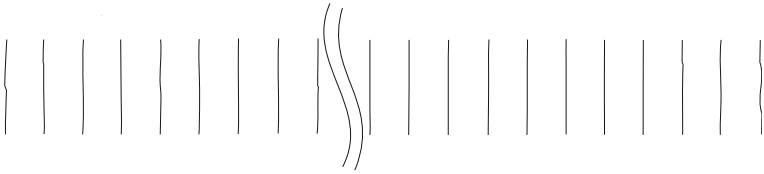

9. When the bidirectional alignment is satisfactory, press **Start/Stop** to exit the bidirectional alignment mode.

Removal Procedures

Use the following procedures to remove and replace individual FRUs. The procedures in this section are mainly for the 2380 and 2390 printers. When a procedure for the 2381 and 2391 printers differ, the procedure for the 2381 and 2391 is described under “Wide Carriage”.

CAUTION: Be sure to unplug the power cord whenever you are working on the printer with one of the covers removed.

Auto Sheet Feeder Gears Removal

1. Remove the right cover.
2. Release the latch [A], and then remove the joint gear [1].
3. Remove the idler gear [2].
4. Release the latch [A], and then remove the idler gear [3].
5. Release the latch [8], and then remove the pick-up gear [4].
6. Release the latch [A], and then remove the combination lock mechanism [5].
7. Remove the tension plate [10] on the locker cam [6].
8. Remove the locker cam [6].
9. Release the latch [9], and then remove the lift gear [7].

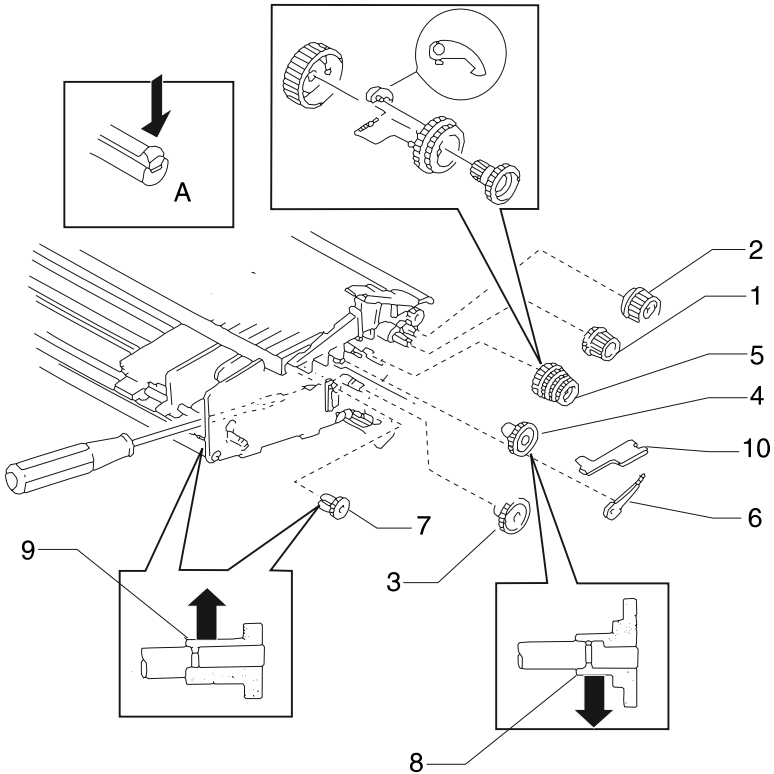

Auto Sheet Feeder Pick-up Roller Removal

1. Remove the covers and the cut sheet support.
2. Remove the idler gear and pick-up gear
see “Auto Sheet Feeder Gears Removal” on page 4-8.
3. Remove the left roller bushing [1] as shown.
4. Remove the right roller bushing [2].
5. Move the pick-up roller [3] to both ends of the shaft, and then remove them.

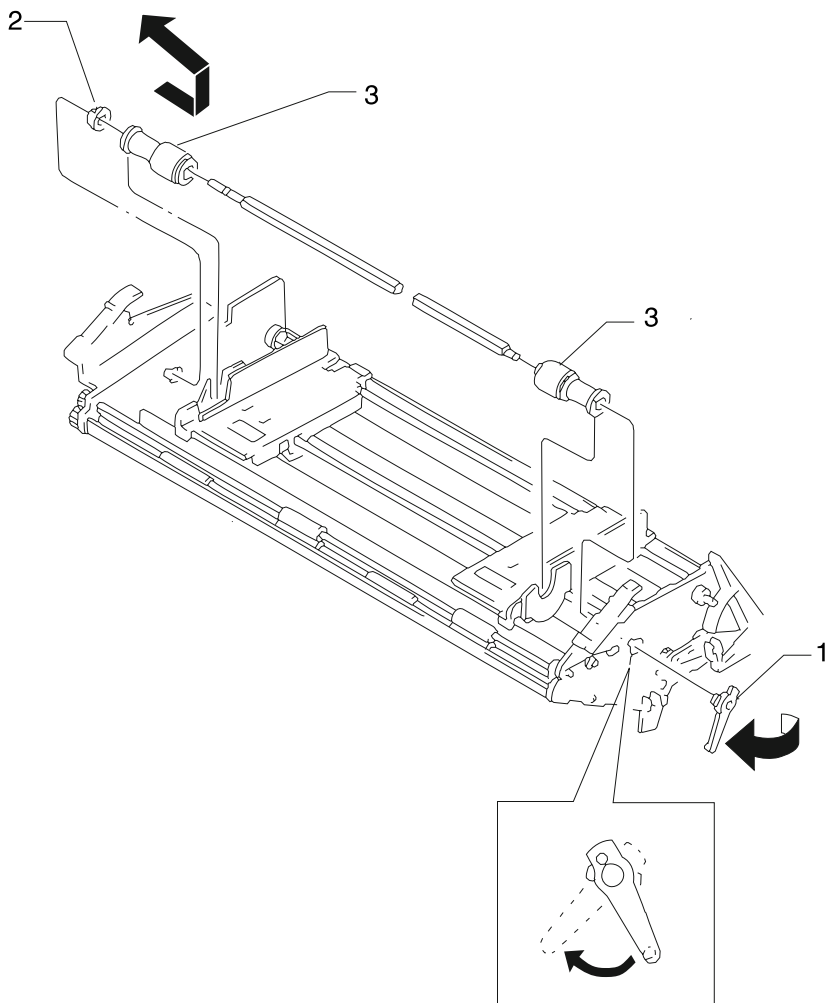

Bottom Cover Removal

1. Remove the tractor assembly
see “[Push Tractor Assembly Removal](#)” on page 4-53.
2. Remove the top cover
see “[Top Cover Removal](#)” on page 4-61.
3. Remove the main logic board
see “[Main Logic Board Removal](#)” on page 4-33.
4. Remove the power supply unit
see “[Power Supply Removal](#)” on page 4-46.
5. Remove the print unit see “[Print Unit Removal](#)” on page 4-47.
6. Remove the rubber board support [5].
7. **2380 & 2390** - Release the two latches [1] and then remove the Main Logic Board ground plate [2] by sliding it toward you.
 - **2381 & 2391** - Remove the two screws securing the Main Logic Board ground plate [2] to the bottom cover. Release the two latches [1] and then remove the Main Logic Board ground plate from the bottom cover by sliding it toward you.
8. Release the two latches [1] then remove the power supply ground plate [4] by sliding it toward you.

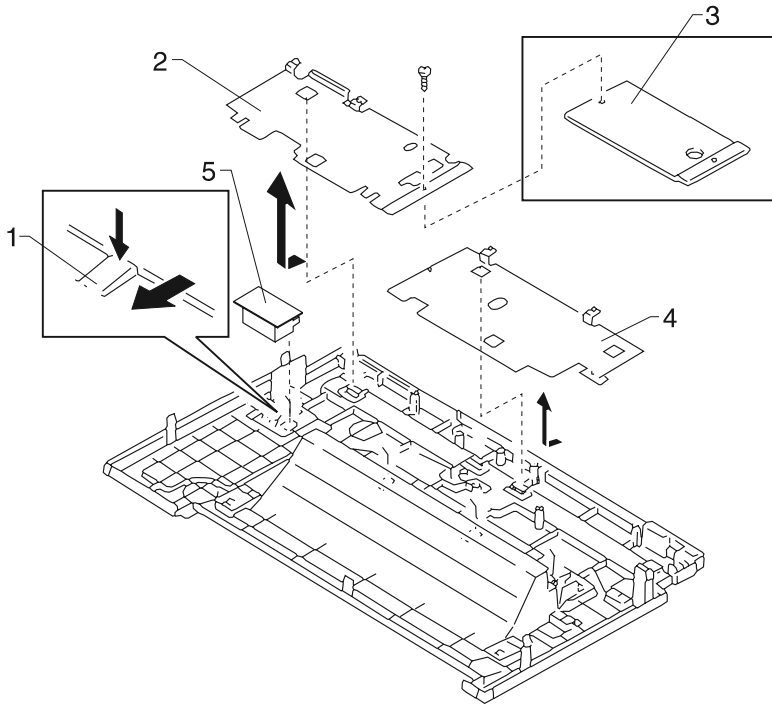

Repair Information 4-11

Carrier Removal

1. Remove the top cover
see “**Top Cover Removal**” on page 4-61.
2. Remove the printhead
see “**Printhead Removal**” on page 4-48.
3. Remove the printhead cables from the carrier assembly
see “**Printhead Cables Removal**” on page 4-49.
4. Remove the sub logic board
see “**Sub Logic Board Removal**” on page 4-59.
5. Remove the paper feed motor and the paper feed motor plate
see “**Paper Guide / Platen Assembly Removal**” on page 4-40.
6. Move the carrier to the center of the printer.
7. Remove the belt tension spring [1] from the hook closest to the tension pulley.
8. Loosen the screw [4] securing the tension pulley plate asm [2].
9. Remove the carrier belt [3] from the tension pulley.

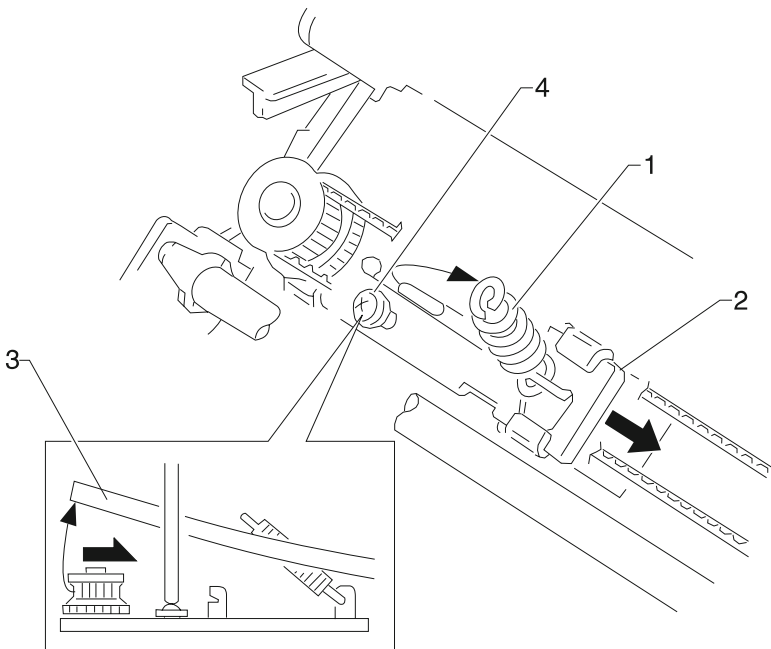

10. Release the ground spring [11] from the end of the carrier shaft; the spring need not be removed.
11. Rotate the left carrier bushing.

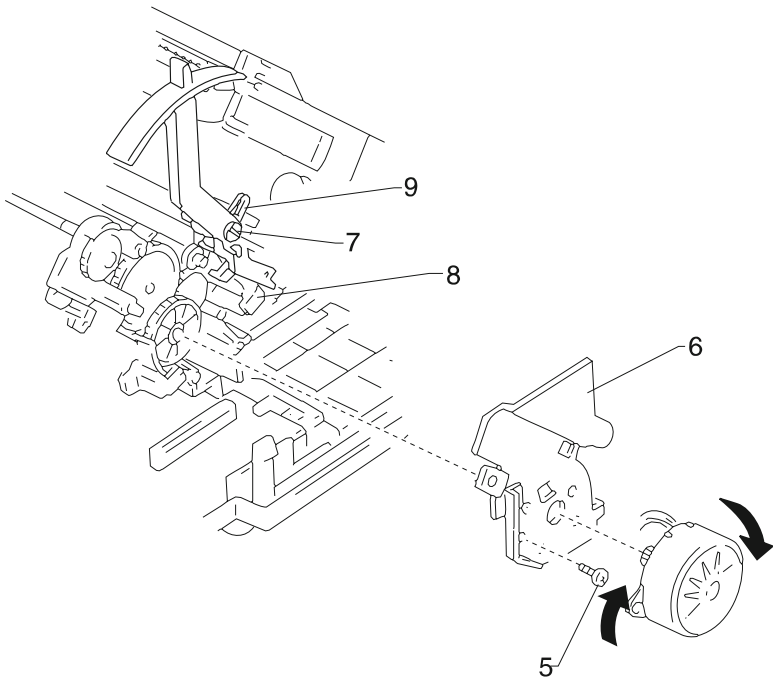

12. Remove the lever stop bracket from the carrier motor (bracket not present on all machines).
13. Release the latch [8] and slide the carrier shaft and forms thickness lever to the left and remove them together from the printer. Do not to lose the gap set collar [15] attached to the right end of the carrier shaft.
14. Lift the rear of the carrier [12] to disengage the carrier ribbon drive gears, then remove the carrier. Do not to lose the oil felt [14].
15. Be sure to get the carrier shaft correctly through the oil felt.
16. Perform the Printhead-to-Platen Gap Adjustment see **“Printhead-to-Platen Gap Adjustment”** on page 4-2.

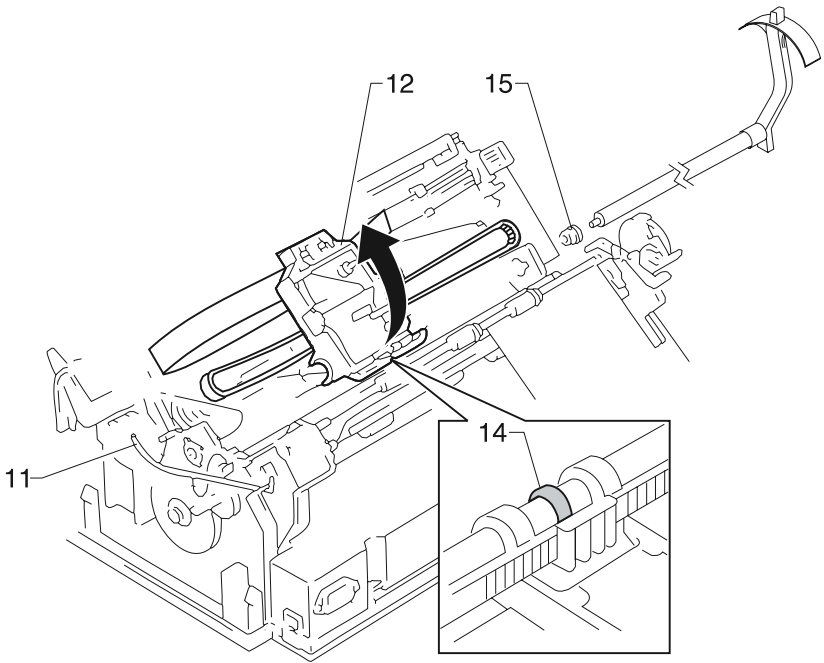

This Page Intentionally Blank.

Carrier Motor Assembly Removal

1. Remove the top cover
see **“Top Cover Removal”** on page 4-61.
2. Remove the sub logic board
see **“Sub Logic Board Removal”** on page 4-59.
3. Move the carrier to the center of the printer.
4. Remove the belt tension spring [1] and loosen the screw [2].
5. Remove the carrier belt [3] from the tension pulley and the carrier motor pulley.

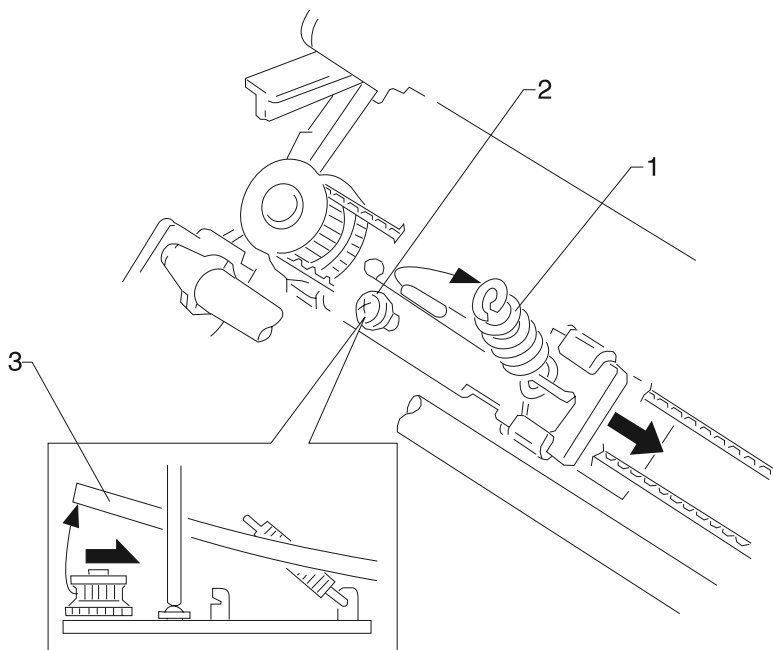

6. Disconnect the carrier motor cable [4] from connector CN9 on the main logic board.
7. Remove the screws [5] and [6] and then remove the carrier motor assembly from the left side frame.

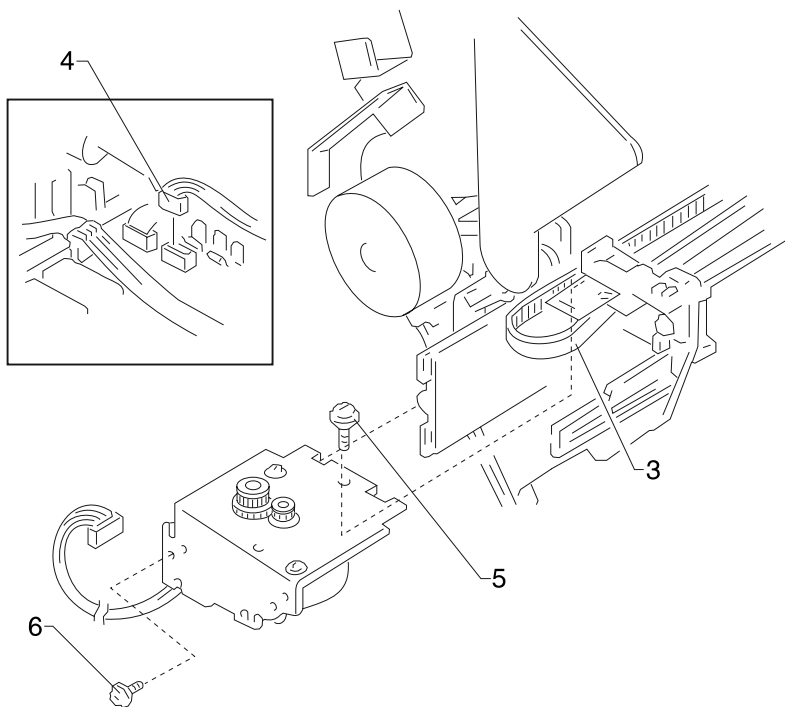

Carrier Plate Removal

1. Remove the tractor assembly
see “[Push Tractor Assembly Removal](#)” on page 4-53.
2. Remove the top cover
see “[Top Cover Removal](#)” on page 4-61.
3. Remove the paper select lever
see “[Paper Select Lever Removal](#)” on page 4-42.
4. Remove the printhead
see “[Printhead Removal](#)” on page 4-48.
5. Remove the printhead cables
see “[Printhead Cables Removal](#)” on page 4-49.
6. Remove the sub logic board
see “[Sub Logic Board Removal](#)” on page 4-59.
7. Remove the paper feed motor
see “[Paper Guide / Platen Assembly Removal](#)” on page 4-40.
8. Remove the carrier motor assembly
see “[Carrier Motor Assembly Removal](#)” on page 4-16.
9. Remove the tension pulley plate assembly
see “[Tension Pulley Plate Assembly](#)” on page 4-60.
10. Remove the carrier see “[Carrier Removal](#)” on page 4-12.
11. **23XX-002, 003:** Remove the tractor idler gear.
12. **23XX-002, 003:** Remove the support plate.
13. Remove the lower pinch roller
see “[Lower Pinch Roller Removal](#)” on page 4-32.
14. Remove the gears on the right side frame
see “[Right Side Frame Gears Removal](#)” on page 4-58.
15. Remove the ribbon drive rack gear
see “[Ribbon Drive Rack Gear Removal](#)” on page 4-54.
16. Remove the home position sensor
see “[Home Position Sensor Removal](#)” on page 4-25.
17. Remove the paper separator spring [2].
18. Remove the screw [3] from the paper separator.
19. **23XX-001, 002** - Release the latch, and then remove the release slider cam [4] from the right side frame.
23XX-003 - Remove the slider cam screw and spring. Remove the sub slider cam and the slider cam from the right side frame.
20. Remove the two screws [5] and the screw [6].

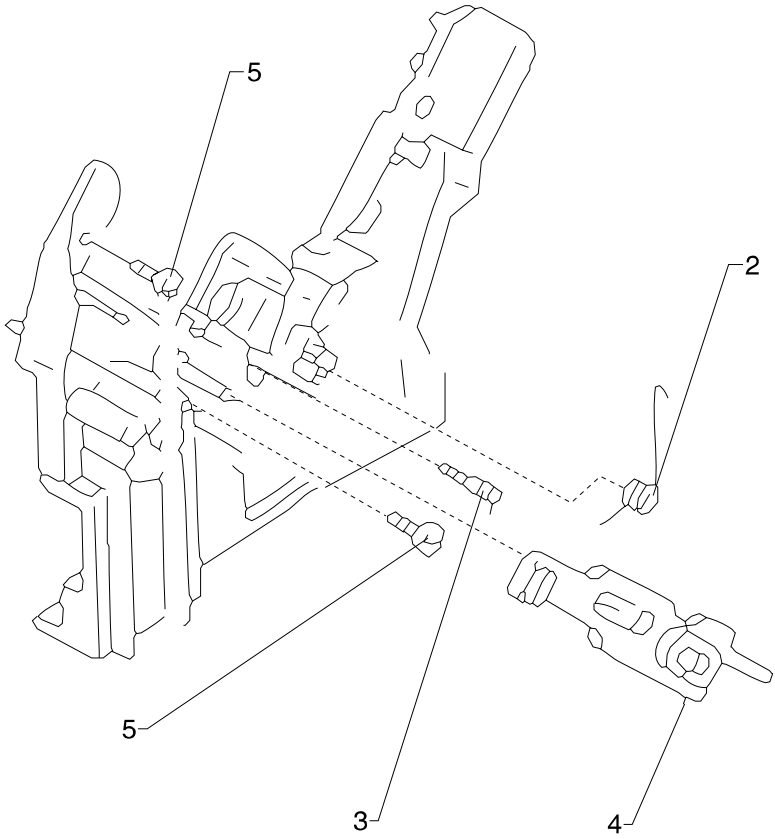

Right Side

Repair Information 4-19

21. Gently bend both side frames outward to release tabs [7] from the slots [8]. Lift and remove the carrier plate.

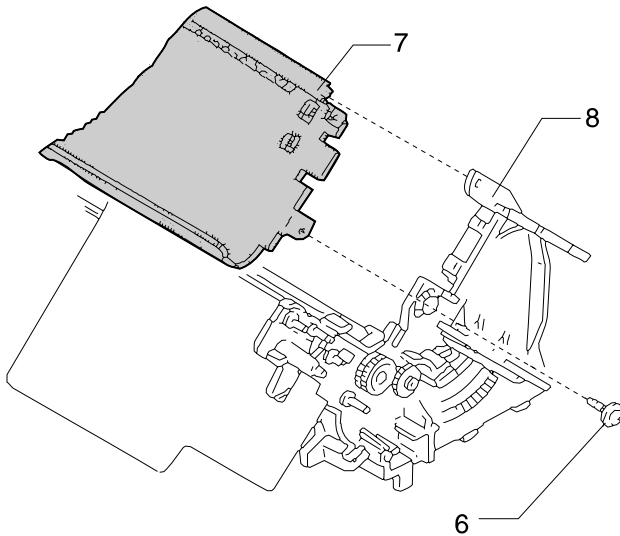

Left Side

Download or Print Buffer Module Removal

Notes:

- Turn the printer **Off** and disconnect the power cord at the printer.
- The Download Module and the Print Buffer Module are options.
 1. Remove the rear cover.
 2. Remove the paper support.
 3. Insert a small flat screwdriver [1] under each end of the module and lift up gently. (On 23XX-002, 003 printers only one end of the module is accessible.) Do not insert the screwdriver too deep, or the main logic board may be damaged.

Note: Be careful not to bend the pins when you re-install the module.

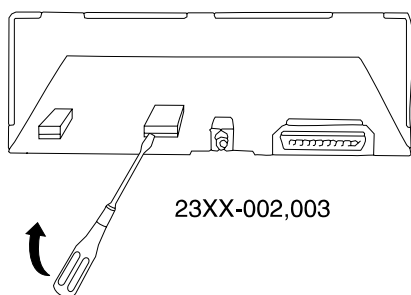
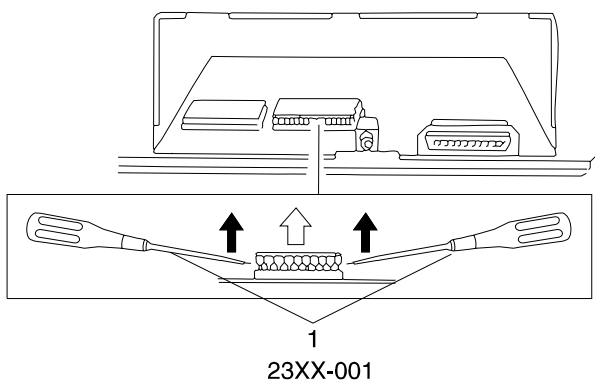

Form Thickness Lever Removal

1. Remove the top cover
see “**Top Cover Removal**” on page 4-61.
2. Remove the sub logic board
see “**Sub Logic Board Removal**” on page 4-59.
3. Remove the paper feed motor and the paper feed motor plate
see “**Paper Guide / Platen Assembly Removal**” on page 4-40.
4. Remove the lever stop bracket from the carrier motor
(bracket not present on all machines).
5. Remove the screw and washer [3].
6. Release the latch [4] and remove the form thickness lever [5].

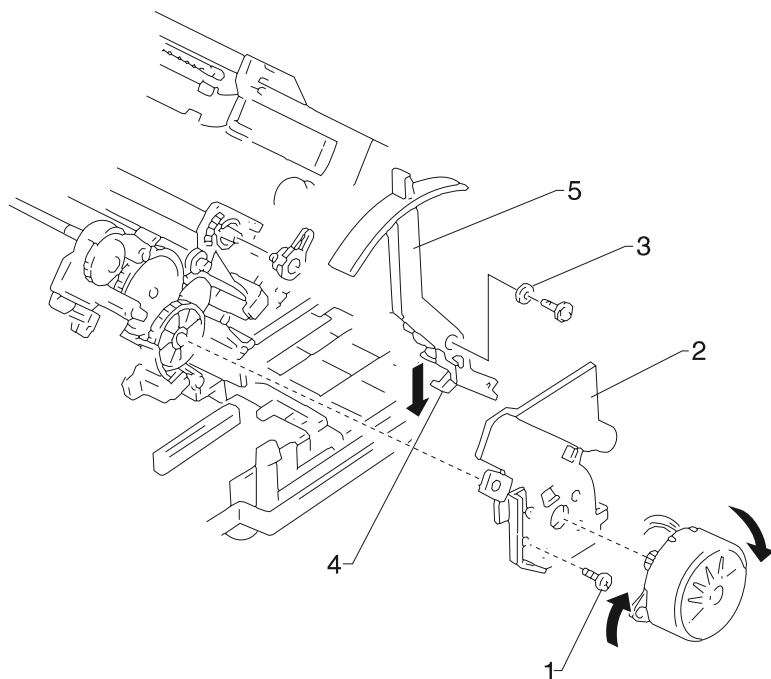

Head Gap Sensor Removal (238X-001)

1. Remove the top cover
see “[Top Cover Removal](#)” on page 4-61.
2. Remove the sub logic board
see “[Sub Logic Board Removal](#)” on page 4-59.
3. Remove the paper feed motor and the paper feed motor plate
see “[Paper Guide / Platen Assembly Removal](#)” on page 4-40.
When the paper feed motor plate is removed, the idler gear [3]
may come off simultaneously.
4. Remove the head gap sensor [2].

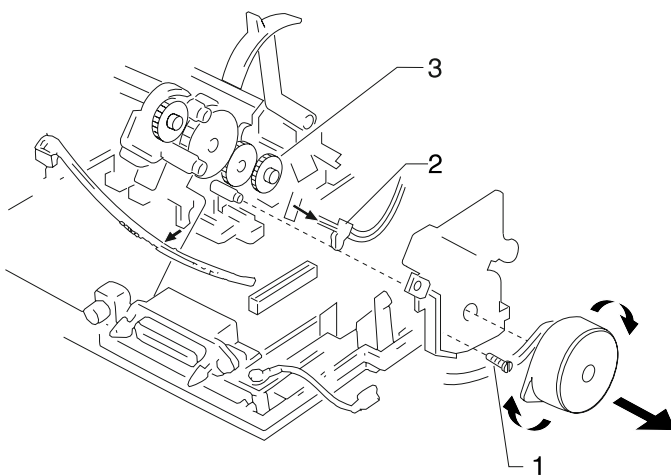

Head Gap Sensor Removal (23XX-002, 003)

1. Remove the top cover
see “**Top Cover Removal**” on page 4-61.
2. Remove the sub logic board
see “**Sub Logic Board Removal**” on page 4-59.
3. Remove the paper feed motor and the paper feed motor plate
see “**Paper Guide / Platen Assembly Removal**” on page 4-40.
4. Move the forms thickness lever to position 7.
5. Remove the screw [1] and remove the head gap sensor assembly [2].
6. When you re-install the sensor, be sure the rear of the head gap sensor assembly is held in place by the paper feed motor plate.

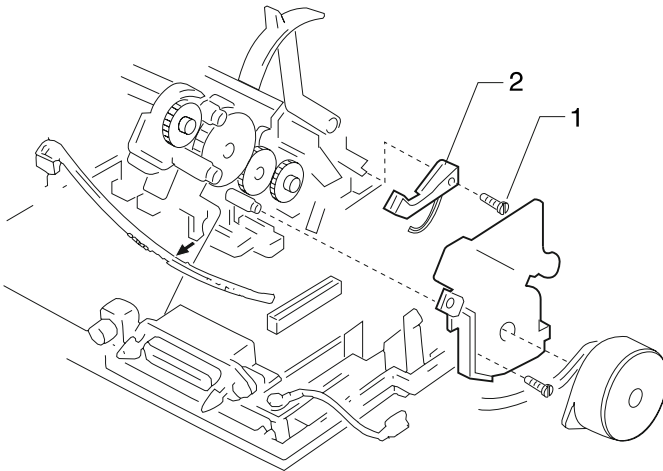

Home Position Sensor Removal

1. Remove the top cover
see “**Top Cover Removal**” on page 4-61.
2. Disconnect the home position sensor cable from the sub logic board.
3. Remove the screw [1], and then remove the home position sensor from the left side frame. The sensor is attached to the left side support plate on newer models.

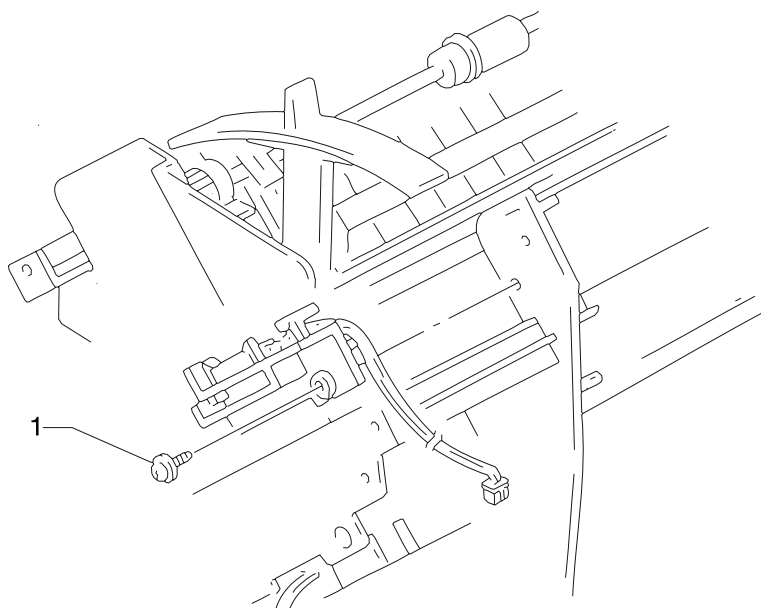

Label Jam Removal

When a pressure-sensitive label that separates from its protective backing has jammed and stuck to the paper separator and/or below the carrier plate, the following procedure should be used to remove the jammed label.

1. Remove the top cover
see **“Top Cover Removal”** on page 4-61.
2. Remove the tractor assembly
see **“Push Tractor Assembly Removal”** on page 4-53.
3. Remove the print unit see **“Print Unit Removal”** on page 4-47.
4. Remove the paper separator
see **“Paper Separator Removal”** on page 4-44.
5. Carefully remove the jammed label from the mylar strip on the paper separator. If the mylar strip is damaged, replace the paper separator. If the label is jammed below the carrier plate or on the lower plastic portion of the paper guide/platen assembly, carefully remove the jammed label without scratching either surface or damaging the mylar strips that rest on the lower feed rollers.

This Page Intentionally Blank.

Left Side Frame Removal

1. Remove the tractor assembly
see [“Push Tractor Assembly Removal”](#) on page 4-53.
2. Remove the top cover
see [“Top Cover Removal”](#) on page 4-61.
3. Remove the pull tractor actuator
see [“Pull Tractor Actuator Removal”](#) on page 4-51.
4. Remove the printhead
see [“Printhead Removal”](#) on page 4-48.
5. Remove the sub logic board
see [“Sub Logic Board Removal”](#) on page 4-59.
6. Remove the paper feed motor and paper feed motor plate
see [“Paper Guide / Platen Assembly Removal”](#) on page 4-40.
7. Remove the carrier motor assembly
see [“Carrier Motor Assembly Removal”](#) on page 4-16.
8. Remove the carrier see [“Carrier Removal”](#) on page 4-12.
9. Remove the upper feed roller
see [“Upper Feed Roller Removal”](#) on page 4-66.
10. Remove the lower pinch roller
see [“Lower Pinch Roller Removal”](#) on page 4-32.
11. Remove the print unit see [“Print Unit Removal”](#) on page 4-47.
12. Remove the home position sensor
see [“Home Position Sensor Removal”](#) on page 4-25.
13. Remove the pull tractor sensor
see [“Pull Tractor Sensor Removal”](#) on page 4-52.
14. **238X-001** - Remove the head gap sensor
see [“Head Gap Sensor Removal \(238X-001\)”](#) on page 4-23.
23XX-002, 003 - Remove the head gap sensor assembly
see [“Head Gap Sensor Removal \(23XX-002, 003\)”](#) on page 4-24.
15. Remove the large idler gear [7] by inserting a small blade screwdriver between the gear and the side frame and twisting.
16. **23XX-002, 003** - Remove the screw [8] that was covered by the gear and remove the metal support plate. Remove the platen bar screw [8] that was covered by the support plate.
23XX-001 printers have only one screw to remove.
17. **238X-XXX** - Remove the idler gear [1].
18. Remove the lower left feed roller gear [2].
19. Release the latch, and then remove the left lower bushing [3].

20. Remove the screw [4].
21. Release the two latches [5].
22. Remove the left side frame.
23. Be sure to perform the Printhead-to-Platen Gap Adjustment after you re-assemble the printer.
see **“Printhead-to-Platen Gap Adjustment”** on page 4-2.

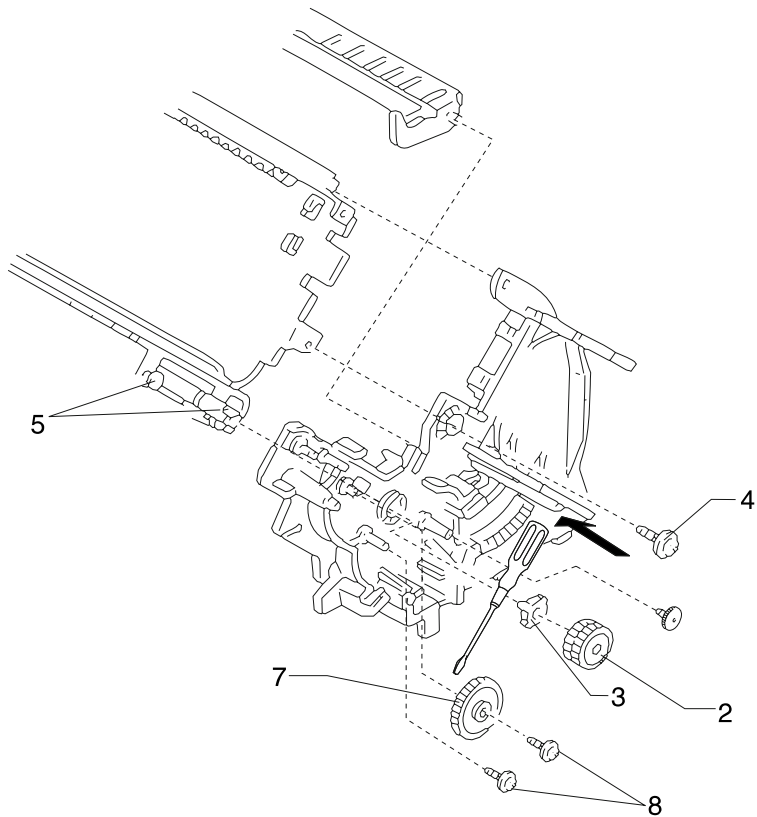

Lower Feed Roller Removal

1. Remove the tractor assembly
see [“Push Tractor Assembly Removal”](#) on page 4-53.
2. Remove the top cover
see [“Top Cover Removal”](#) on page 4-61.
3. Remove the pull tractor actuator
see [“Pull Tractor Removal”](#) on page 4-50.
4. Remove the paper select lever
see [“Paper Select Lever Removal”](#) on page 4-42.
5. Remove the printhead
see [“Printhead Removal”](#) on page 4-48.
6. Remove the sub logic board
see [“Sub Logic Board Removal”](#) on page 4-59.
7. Remove the paper feed motor
see [“Paper Guide / Platen Assembly Removal”](#) on page 4-40.
8. Remove the carrier see [“Carrier Removal”](#) on page 4-12.
9. Remove the upper feed roller
see [“Upper Feed Roller Removal”](#) on page 4-66.
10. Remove the lower pinch roller
see [“Lower Pinch Roller Removal”](#) on page 4-32.
11. Remove the gears on the right side frame
see [“Right Side Frame Gears Removal”](#) on page 4-58.
12. Remove the print unit see [“Print Unit Removal”](#) on page 4-47.
13. Remove the right side frame
see [“Right Side Frame Removal”](#) on page 4-56.
14. Remove the idler gear [1], then remove the left feed roller lower gear [2].
15. Release the latch, and then remove the left lower bushing [3].
16. On wide carriage machines remove the ground strap from the center of the platen.
17. Release the notch on the left of the lower feed roller [4] from tab [A] on the left side frame, and then remove the lower feed roller.
18. Be sure to perform the Printhead-to-Platen Gap Adjustment
see [“Printhead-to-Platen Gap Adjustment”](#) on page 4-2.

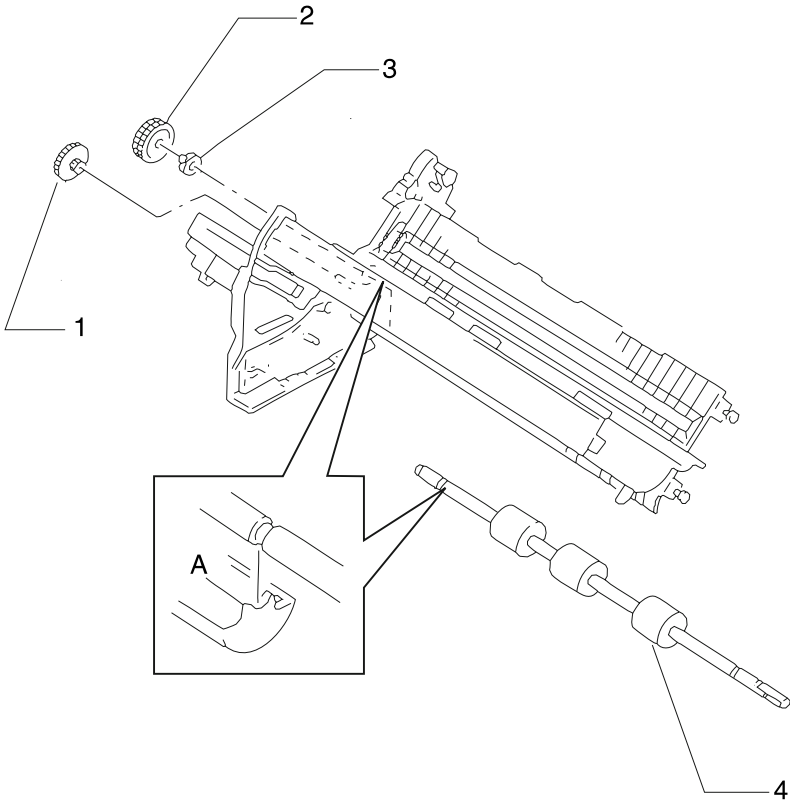

Repair Information 4-31

Lower Pinch Roller Removal

Note: The lower pinch roller and the pinch roller gear must be ordered separately.

1. Remove the top cover
see [“Top Cover Removal”](#) on page 4-61.
2. Remove the center pinch roller ground spring.
3. Remove the left and right pinch roller springs [1].
4. Move the carrier to the right as far as it will go.
5. Slide the left end of the lower pinch roller to the front of the printer and lift it up and to the left to remove it.
6. Be sure to perform the [Printhead-to-Platen Gap Adjustment](#) procedure see [“Printhead-to-Platen Gap Adjustment”](#) on page 4-2.

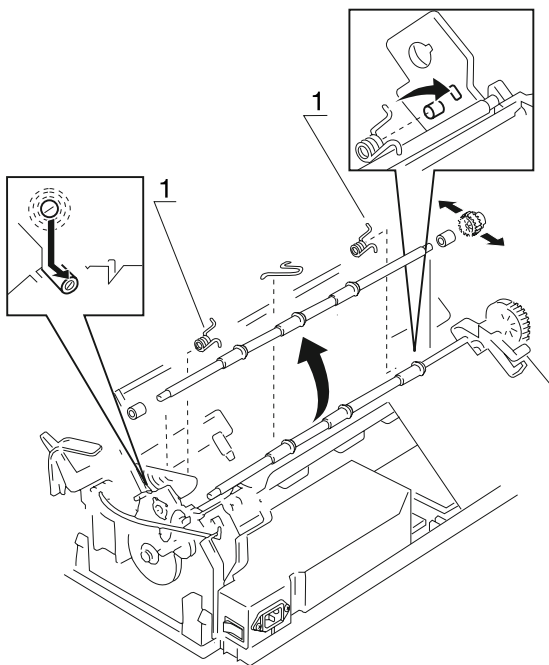

Main Logic Board Removal

1. Remove the top cover
see “Top Cover Removal” on page 4-61.
2. Disconnect all cables connected to the main logic board
connectors may not be exactly as shown.

Note: Do not twist the flexible cable when disconnecting CN3.

3. Remove the two screws [1] and then remove the main logic board by pulling it out towards the back.
4. Replace the main logic board.
5. Be sure to check the Bidirectional Print Adjustment after you install the board.

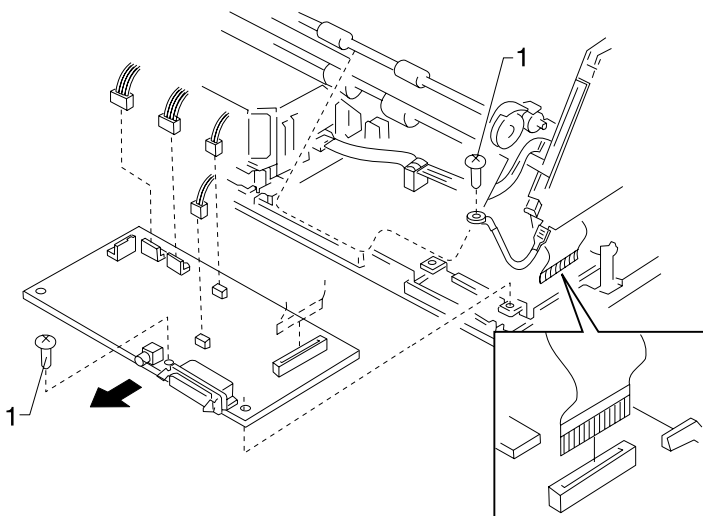

Operator Panel Assembly Removal

1. Remove the top cover
see “Top Cover Removal” on page 4-61.
2. Release the two latches [1], and then remove the operator panel assembly.

Note: Be sure the flexible cable is correctly aligned and inserted securely. The end with the 90 degree fold connects to the sub logic board.

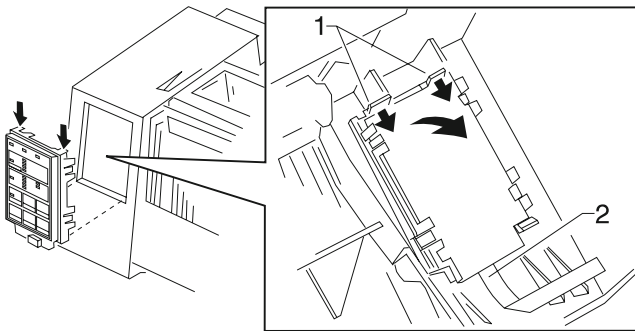

This Page Intentionally Blank.

Paper Empty Sensor And Spring Removal

1. Remove the tractor assembly
see **“Push Tractor Assembly Removal”** on page 4-53.
2. Remove the top cover
see **“Top Cover Removal”** on page 4-61.
3. Remove the print unit see **“Print Unit Removal”** on page 4-47.
4. Remove the paper select lever
see **“Paper Select Lever Removal”** on page 4-42.
5. Release the four latches [1], and then remove the paper empty sensor. Carefully remove the paper empty sensor cable to avoid cable damage.
6. Disconnect the paper empty sensor cable from the latch on the paper guide.
7. Carefully grasp the paper empty lever at [2] with a pair of needle nose pliers and remove the paper empty lever by pulling it perpendicular away from the paper guide. Do not damage or lose the paper empty sensor spring [3].
8. Detach the paper empty sensor spring [3].

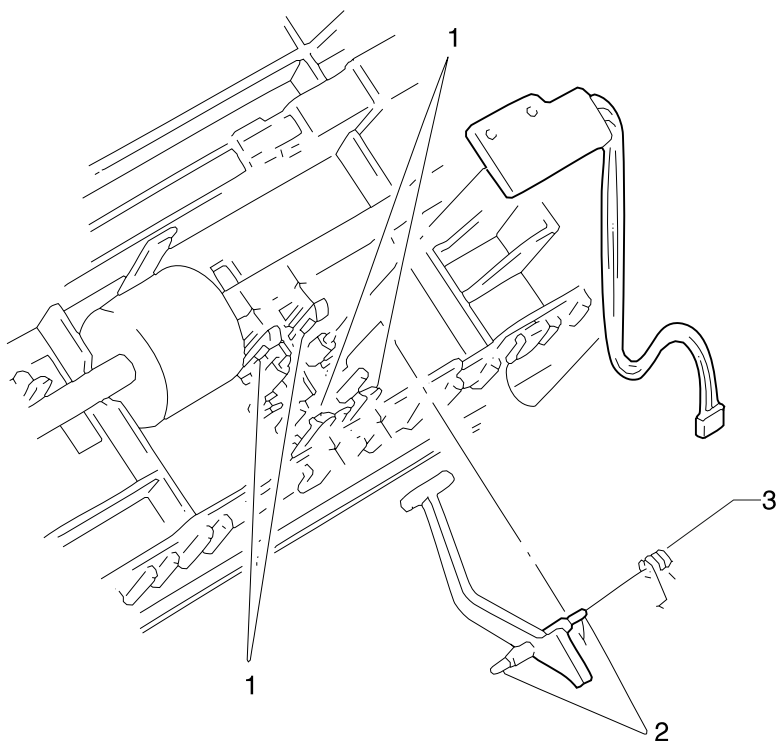

Repair Information 4-37

Paper Feed Motor Removal

1. Remove the top cover
see “**Top Cover Removal**” on page 4-61.
2. Remove the sub logic board
see “**Sub Logic Board Removal**” on page 4-59.
3. Disconnect the paper feed motor cable [1] from connector CN10 on the main logic board.
4. Remove the screw [3].
5. Rotate the paper feed motor [2] clockwise, then remove it. The paper feed motor plate [4] can also be removed at this time as it is held in place only by the motor [2].
238X-001 - The head gap sensor may come loose. It is held in place by the paper feed motor plate.
6. **238X-001** - Be sure the head gap sensor is positioned correctly before installing the paper feed motor plate.

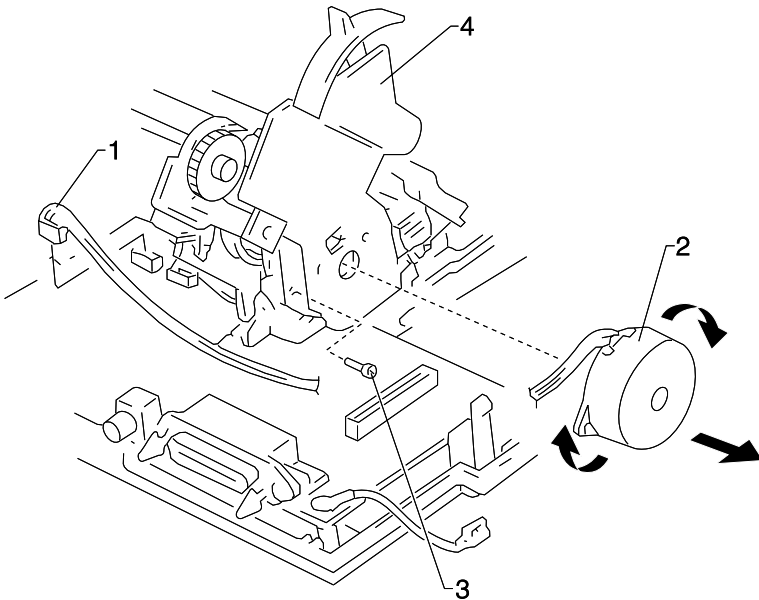

Paper Guide Removal (Left And Right)

1. Remove the front cover and place it front down on a flat surface.
2. Press down the paper guide [1], release the two latches, and remove the paper guide.

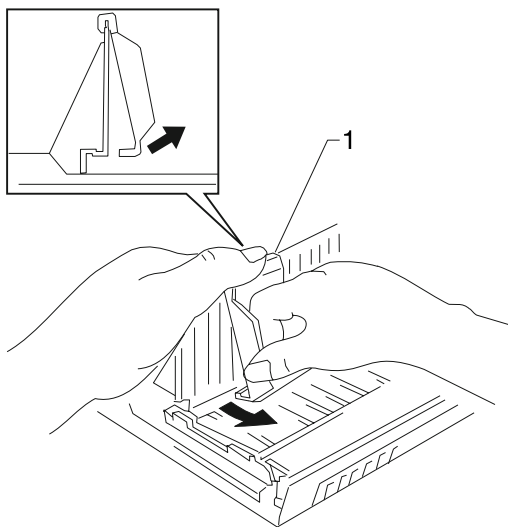

Paper Guide / Platen Assembly Removal

1. Remove the tractor assembly
see [“Push Tractor Assembly Removal”](#) on page 4-53.
2. Remove the top cover
see [“Top Cover Removal”](#) on page 4-61.
3. Remove the pull tractor actuator
see [“Pull Tractor Actuator Removal”](#) on page 4-51.
4. Remove the paper select lever
see [“Paper Select Lever Removal”](#) on page 4-42.
5. Remove the printhead
see [“Printhead Removal”](#) on page 4-48.
6. Remove the sub logic board
see [“Sub Logic Board Removal”](#) on page 4-59.
7. Remove the paper feed motor
see [“Paper Feed Motor Removal”](#) on page 4-38.
8. Remove the carrier see [“Carrier Removal”](#) on page 4-12.
9. Remove the tractor idler gear.
10. **23XX-001** - Remove the platen bar screw that was covered by the gear.
23XX-002, 003 - Remove the rear support plate mounting screw that was covered by the gear. Remove the metal support plate mounting screw and the support plate. Remove the platen bar screw that was covered by the support plate.
11. Remove the upper feed roller
see [“Upper Feed Roller Removal”](#) on page 4-66.
12. Remove the lower pinch roller
see [“Lower Pinch Roller Removal”](#) on page 4-32.
13. Remove the gears on the side frame (right)
see [“Right Side Frame Gears Removal”](#) on page 4-58.
14. Remove the print unit see [“Print Unit Removal”](#) on page 4-47.
15. Remove the right side frame
see [“Right Side Frame Removal”](#) on page 4-56.
16. Remove the lower feed roller
see [“Lower Feed Roller Removal”](#) on page 4-30.
17. Release the two latches [1] on the left side of the paper guide [2], and then remove the assembly from the left side frame.
18. Perform the Printhead-to-Platen Gap adjustment
see [“Printhead-to-Platen Gap Adjustment”](#) on page 4-2.

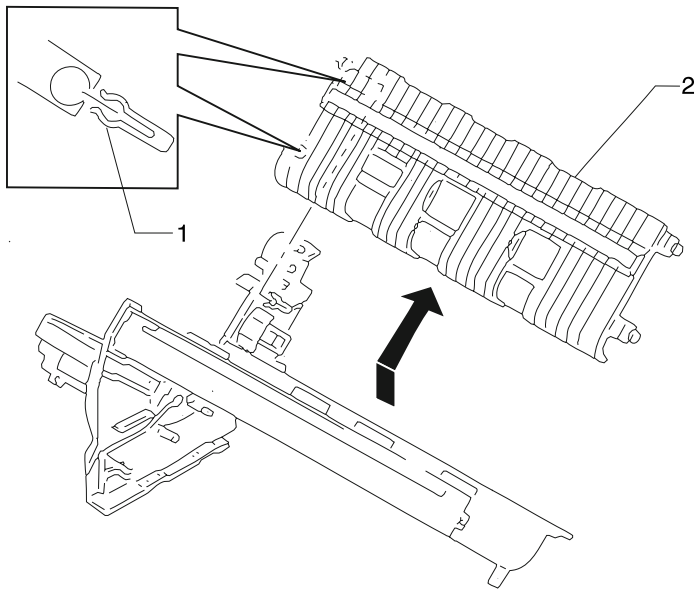

Repair Information 4-41

Paper Select Lever Removal

1. Remove the top cover
see **“Top Cover Removal”** on page 4-61.
2. Release the latch [2] and then remove the paper select lever [1]
from the right side frame.

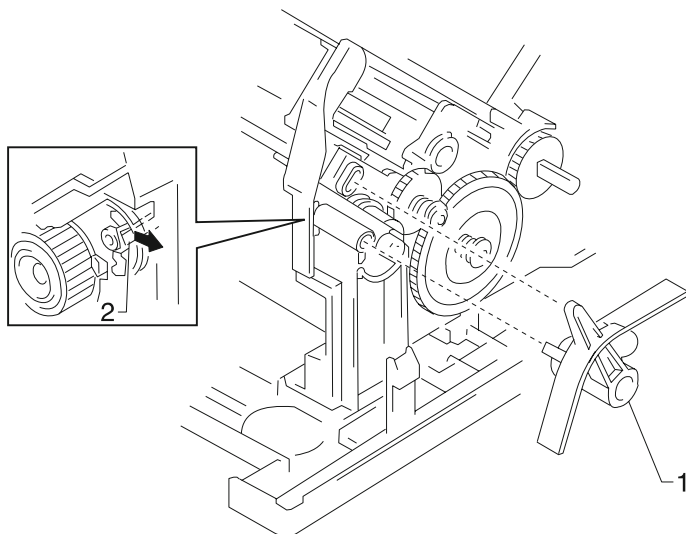

Paper Select Sensor Removal

1. Remove the top cover
see “**Top Cover Removal**” on page 4-61.
2. Remove the print unit see “**Print Unit Removal**” on page 4-47.
3. Using diagonal pliers, cut 4 mm off the ends of the last two ribs on the paper guide to allow better screwdriver access. If necessary, also remove the molded hook on the paper guide.
4. Use a #1 Phillips screwdriver to remove the screw [1] and the sensor [2]. Disconnect the sensor connector from the sub logic board.

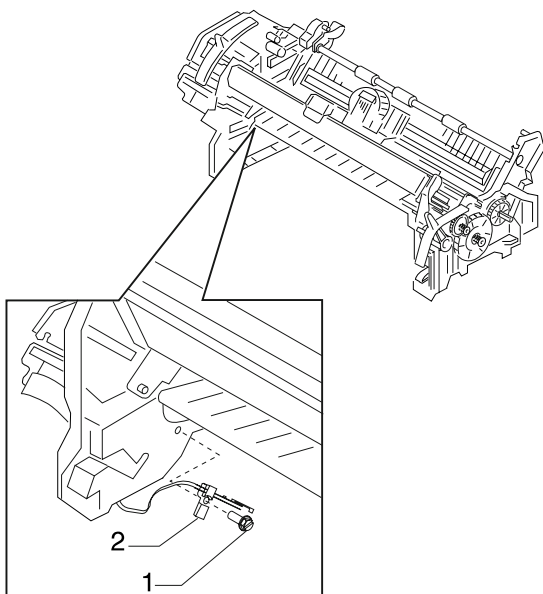

Paper Separator Removal

1. Remove the tractor assembly
see [“Push Tractor Assembly Removal” on page 4-53.](#)
2. Remove the top cover
see [“Top Cover Removal” on page 4-61.](#)
3. Remove the print unit see [“Print Unit Removal” on page 4-47.](#)
4. Remove the carrier shaft retention ground spring [1] located on the right side frame.
5. Position the paper select lever in the continuous forms position (down).
6. Remove the two spring-loaded gears from the right side frame see [“Right Side Frame Gears Removal” on page 4-58.](#)
7. Release the paper separator spring from the screw [2].
8. Remove the separator screw [2] and the two screws [3] that hold the carrier plate to the right side frame.

Warning: The following two steps must be performed with extreme care to avoid damaging the side frames.

9. While holding the front portion of the right side frame and the carrier plate, gently spread the right side frame away from the carrier plate enough to allow the right paper separator pivot [4] to be disengaged from the right side frame pivot hole and into the cutout in the side frame.
10. Again gently spread the right side frame away from the carrier plate enough to allow the left paper separator pivot to be disengaged from the left side frame pivot hole. Remove the paper separator.

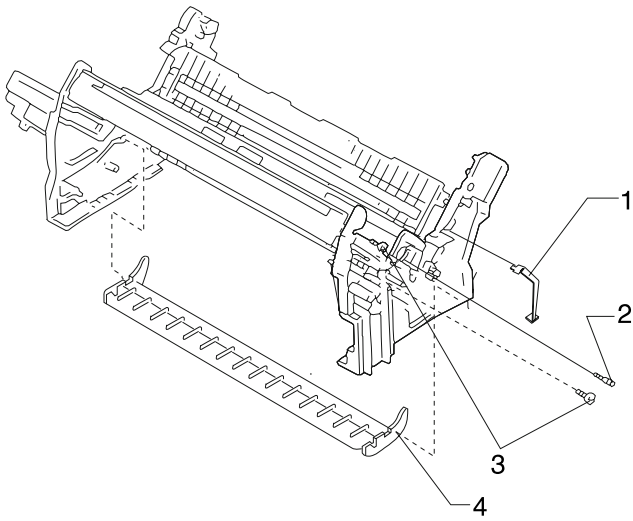

Repair Information 4-45

Power Supply Removal

CAUTION: The power supply may be hot.

1. Turn off the printer and disconnect the power cord at both ends.
2. Remove the top cover
see “Top Cover Removal” on page 4-61.
3. Remove the ground wire screw [1]. Do not lose the star washer [2], if present, located between the ground wire and the shield plate.
4. Disconnect the power supply cable [3].
5. Remove the four mounting screws [4].
6. Remove the power supply.

Reassembly Note: The platen ground leg [5] goes on top of the power supply cover. The ground spring on top of the power supply goes behind the frame support shaft and in front of the upper feed roller shaft.

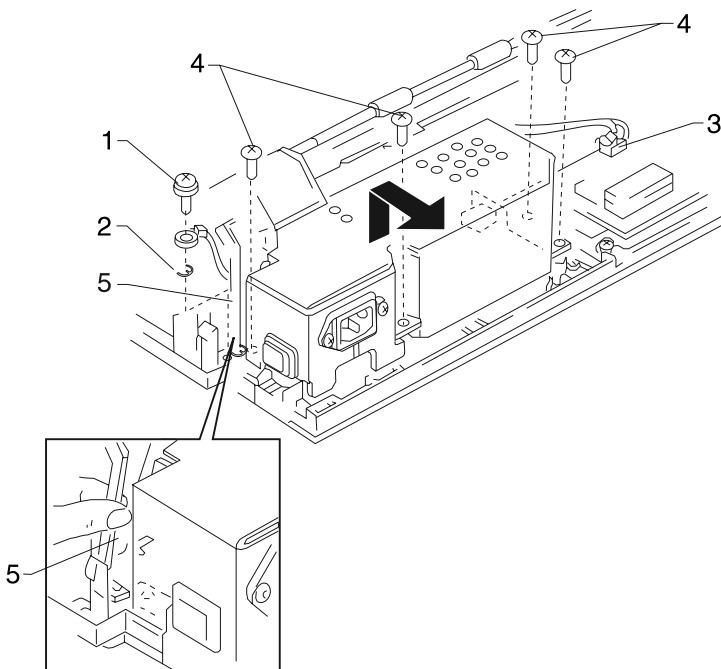

Print Unit Removal

1. Remove the tractor assembly
see **“Push Tractor Assembly Removal”** on page 4-53.
2. Remove the top cover
see **“Top Cover Removal”** on page 4-61.
3. Disconnect all cables connected to the main logic board. Do not bend or twist the flexible cable when disconnecting it from CN3.
4. Disconnect the power supply cable from connector CN1 on the sub logic board.
5. Disconnect the ground wire from the sub logic board plate.
6. Remove the screw [1].
7. Remove two screws [2] and then remove the inserts.
8. Do the following for the left and right side frames. Insert a screwdriver between the bottom front of the side frame and the bottom cover. Raise the screwdriver gently to release the latch while sliding the print unit toward you.
9. Slide the print unit toward you until it stops, then lift to separate the print unit from the bottom cover.

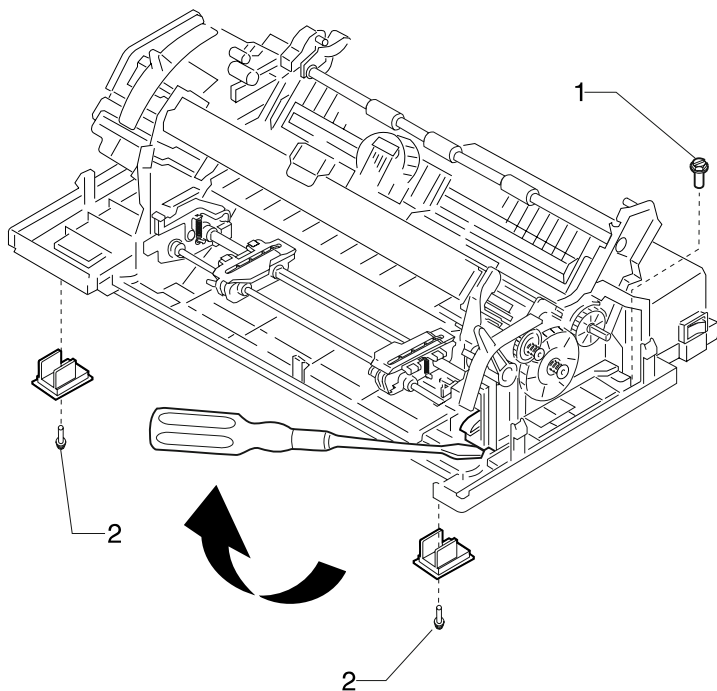

Printhead Removal

1. Turn the printer off.
2. Disconnect the power cord at the printer.
 - Let the printhead cool for 15 minutes before touching it.
 - Be sure to avoid getting your finger stuck between the carrier and ribbon drive rack gear while moving the carrier.
 - Firmly grip the latch for the ribbon cartridge to move the carrier.
3. Before you remove the printhead, set the form thickness lever to position 7.
4. Remove the ribbon access cover.
5. Remove the ribbon cartridge.
6. Release the two latches [1] and then lift the printhead up and remove. If necessary gently pry the printhead upward with a screwdriver inserted under it from the right side.
7. Disconnect the printhead cables [2] from the printhead connector.

Reassembly Note: Be sure the printhead cables are correctly aligned and secured. Be sure to perform the Printhead-to-Platen Gap Adjustment procedure, see [“Bidirectional Print Adjustment”](#) on page 4-5.

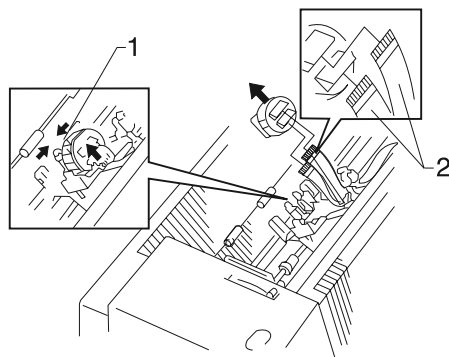

Printhead Cables Removal

Note: Be careful not to damage the printhead cables as they are secured with double-sided adhesive tape.

1. Remove the top cover
see “**Top Cover Removal**” on page 4-61.
2. Remove the printhead
see “**Printhead Removal**” on page 4-48.
3. Release the printhead cables from the flexible cable holders.
4. Disconnect the printhead cables [1] from connector CN8 and CN9 (239X), or CN9 (238X) on the sub logic board [2].

Reassembly Note: Be sure the printhead cables are correctly aligned and secured. They must be flat, with no twists.

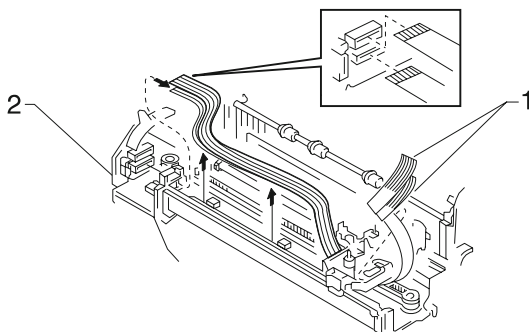

Pull Tractor Removal

1. Press the tractor assembly locking levers [1] down, tilt the tractor assembly in the direction indicated by the arrow and remove it from the printer.

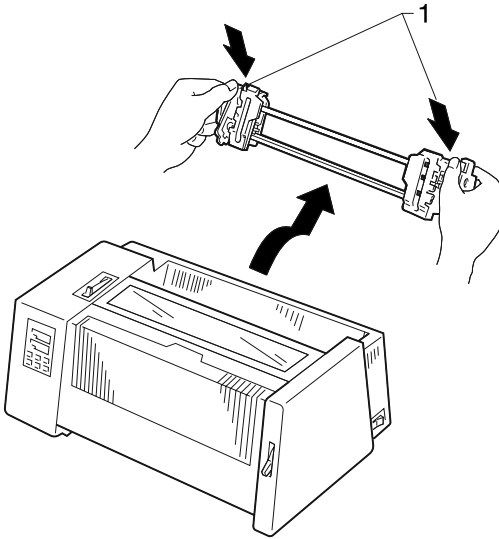

Pull Tractor Actuator Removal

1. If the tractor is installed in the pull tractor position, remove the tractor assembly see “Pull Tractor Removal” on page 4-50.
2. Remove the top cover
see “Top Cover Removal” on page 4-61.
3. Remove the left pull tractor actuator [1].
4. Remove the right pull tractor actuator [2].

Note: If the pull tractor actuator is difficult to remove or is accidentally dropped inside the printer, remove the top cover.

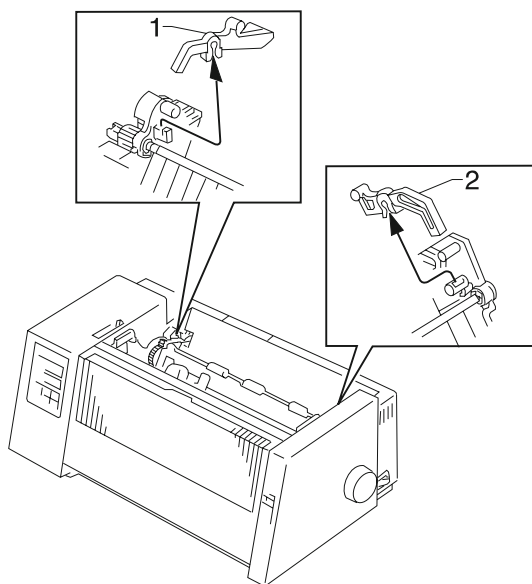

Pull Tractor Sensor Removal

1. Remove the top cover
see **"Top Cover Removal"** on page 4-61.
2. Disconnect the pull tractor sensor cable from connector CN4 on the main logic board.
3. Use a #1 Phillips screwdriver, held in the position shown, to remove the screw, then remove the pull tractor sensor.

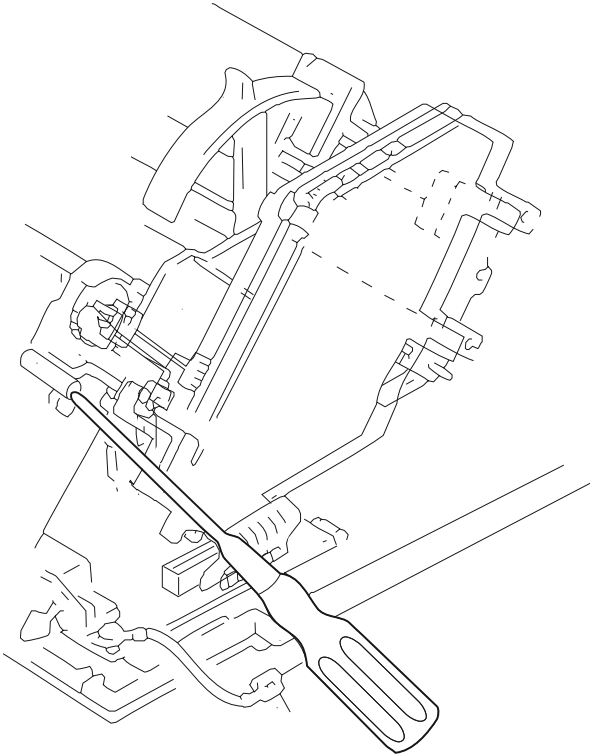

Push Tractor Assembly Removal

1. Open the front cover [1].
2. Press both tractor assembly locking levers [2] down, then pull the tractor assembly [3] straight out of the printer.

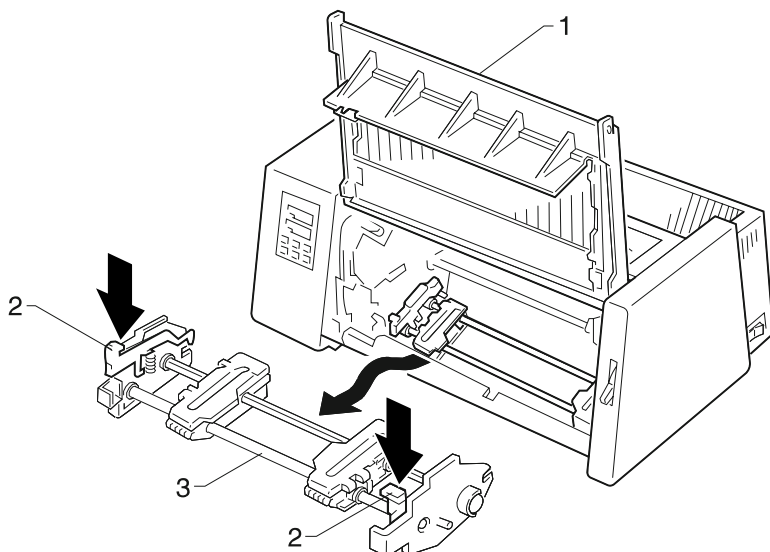

Ribbon Drive Rack Gear Removal

1. Remove the top cover
see **“Top Cover Removal”** on page 4-61.
2. Move the forms thickness lever to position 1.
3. Position the carrier midway between the two rack mounting tabs [1] shown.
4. Remove the stop [2], if present.
5. Release the snap [3] and move the rack [4] to the right.
6. Press the tab on the right, and move the rack down to disengage the rack from the ribbon drive gear.

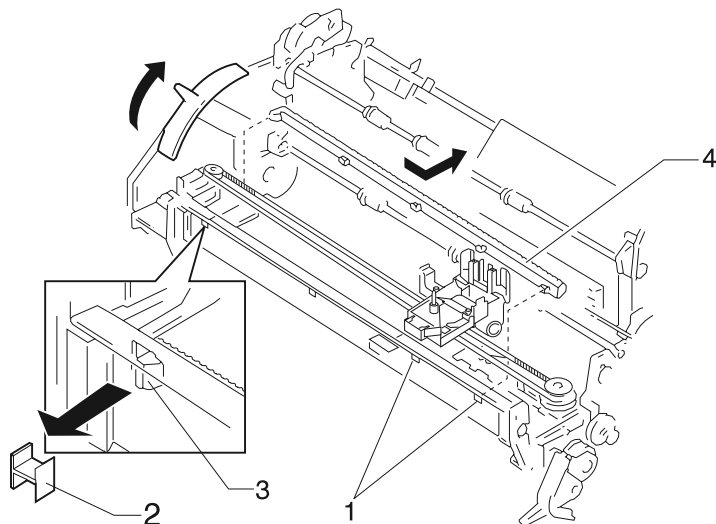

This Page Intentionally Blank.

Right Side Frame Removal

1. Remove the tractor assembly
see [“Push Tractor Assembly Removal” on page 4-53.](#)
2. Remove the top cover
see [“Top Cover Removal” on page 4-61.](#)
3. Remove the paper select lever
see [“Paper Select Lever Removal” on page 4-42.](#)
4. Remove the sub logic board
see [“Sub Logic Board Removal” on page 4-59.](#)
5. Remove the paper feed motor and paper feed motor plate
see [“Paper Guide / Platen Assembly Removal” on page 4-40.](#)
6. Remove the ground spring and the platen-to-power supply ground leg from the right side of the printer.
7. Remove the print unit see [“Print Unit Removal” on page 4-47.](#)
8. Release the spring tension on the carrier belt by loosening the screw and pushing the assembly toward the center carrier plate; tighten the screw to hold it in position.
9. Rotate the left carrier adjustment bushing to unlock it from the left side frame. Release the latch on the forms thickness lever and slide the carrier shaft half way out so it is free of the right side frame. Do not lose the small bushing on the right end of the carrier shaft.
10. Raise the right pinch roller spring and slide the black retainer toward the center of the shaft. Remove the spring from the right side frame.
11. Remove the gears on the right side frame
see [“Right Side Frame Gears Removal” on page 4-58.](#)
12. Remove the paper separator spring [2] and the slider cam [4] and for 23XX-003, the sub slider cam and its spring.
13. Remove the feed roll bushings [1] from the right side frame.
14. Remove the two screws [5] holding the right side frame to the carrier plate.
15. **23XX-002, 003** - Remove the screw [5] holding the right side frame to the support shaft [7].
16. Lift the right end of the carrier plate up and slightly forward.
17. Release the two latches [6] and remove the right side frame.
18. Be sure to perform the Printhead-to-Platen Gap Adjustment see [“Printhead-to-Platen Gap Adjustment” on page 4-2.](#)

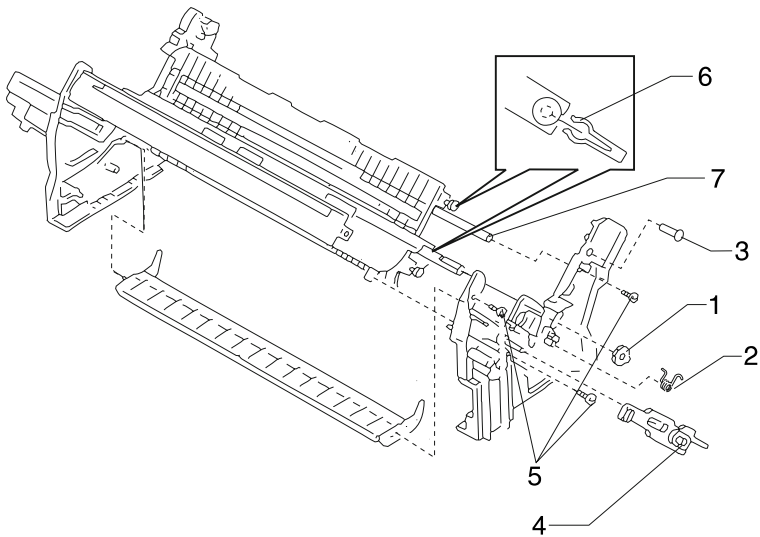

Notes On Replacement:

- Take care not to break the two latches [6] on the side frame that latch to the paper guide.
- Be sure both ends of the paper separator are correctly in the mounting holes.
- Use the new slider cam, if one is included with the new side frame; the old slider cam will not work properly although it may seem to fit.
- The hub side of all gears goes toward the side frame. While installing the large idler gear, the slider should be in the outer position. The conical side of the gear goes toward the side frame. The lower feed roll gear may be a very tight fit.
- **238X-001** - Be sure the head gap sensor is in the correct position while installing the paper feed motor plate.

Right Side Frame Gears Removal

1. Remove the top cover
see "Top Cover Removal" on page 4-61.
2. Set the paper select lever upward to the cut form position.
3. Release the latch [1] and then remove the ASF drive gear.
4. **23XX-003**: Remove the two screws and remove the shaft support plate (not shown).
5. Remove both E rings [2],[3] and then remove the ASF idler gear and the shift gear from the right side together with their washer and spring. To prevent the washer and spring from springing off, hold them down while removing the E ring.
6. Remove the lower feed roller right gear [4].

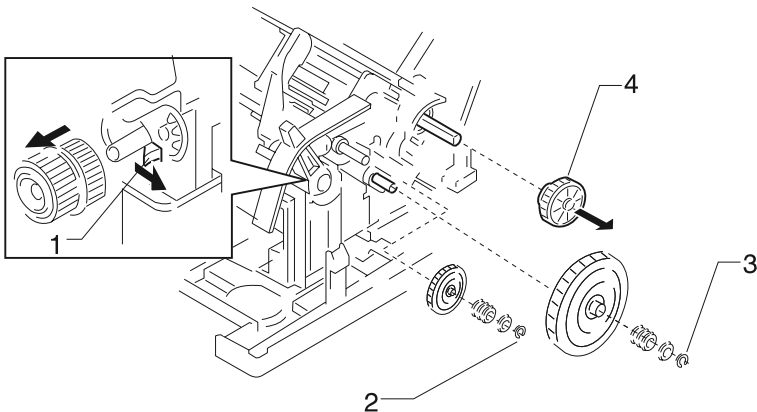

Sub Logic Board Removal

1. Remove the top cover
see “Top Cover Removal” on page 4-61.
2. Disconnect the short flexible cable [5] from connector CN3 on the main logic board.

Note: Do not twist the flexible cable when you disconnect CN3.

3. Disconnect all of the cables connected to the sub logic board [2]. Do not bend or twist the flat cables when you disconnect them from CN7, CN8, and CN9.
4. Disconnect the ground wire [1].
5. Remove the screws [3], [4] and then remove the sub logic board [2]. Note: [4] is a self-tapping screw.
6. To replace, first connect the short flexible cable to the sub logic board at CN2. The contact side of the cable must face the center of the printer.

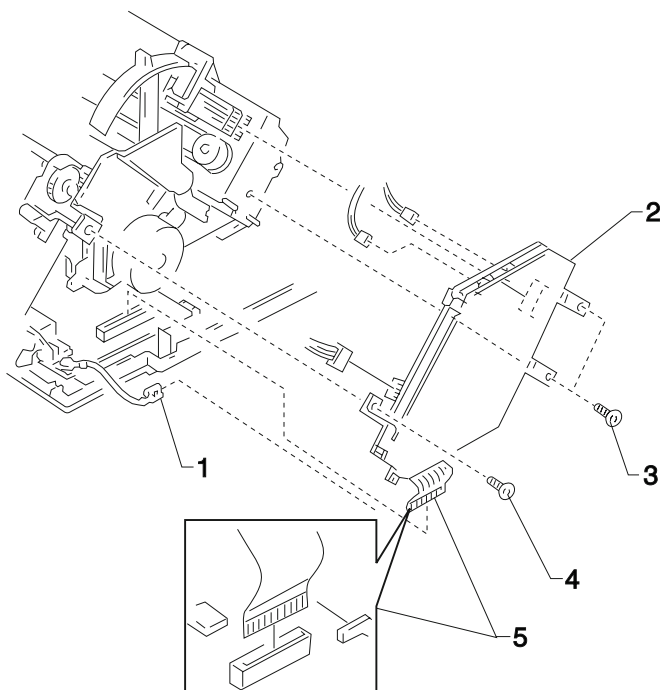

Tension Pulley Plate Assembly

1. Remove the top cover
see **"Top Cover Removal"** on page 4-61.
2. Remove the belt tension spring [1] from the hook.
3. Remove the screw [2].
4. Remove the carrier belt [3].
5. Remove the tension pulley plate assembly [4] by sliding it toward the right (rear view).

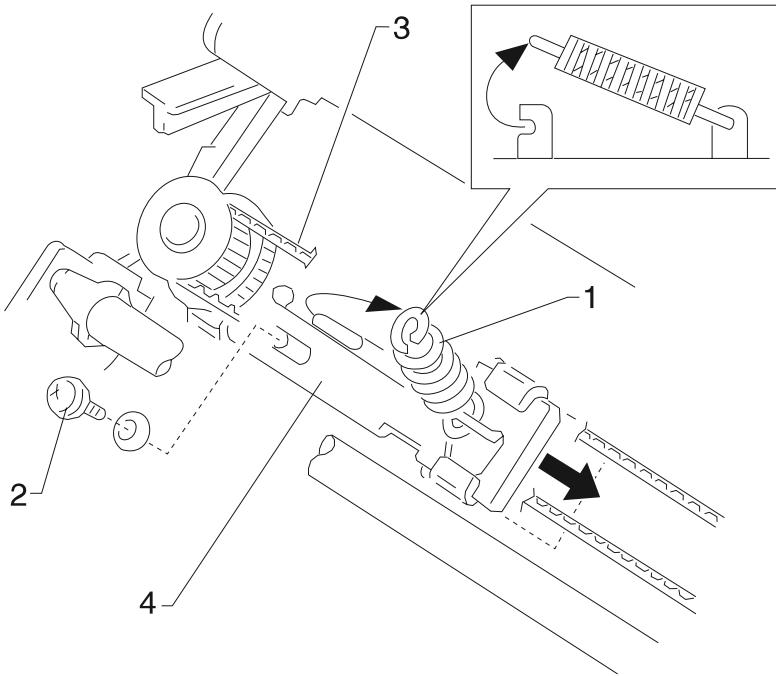

Top Cover Removal

1. Turn the printer off.
2. Disconnect the power cord at the printer.
3. **23XX-001** - Remove the paper advance knob [1] by pulling to the right.
4. If the tractor assembly is installed in the pull tractor position, remove the tractor assembly see **"Pull Tractor Removal"** on page 4-50.
5. Remove the front cover [2] and the ribbon access cover [3].

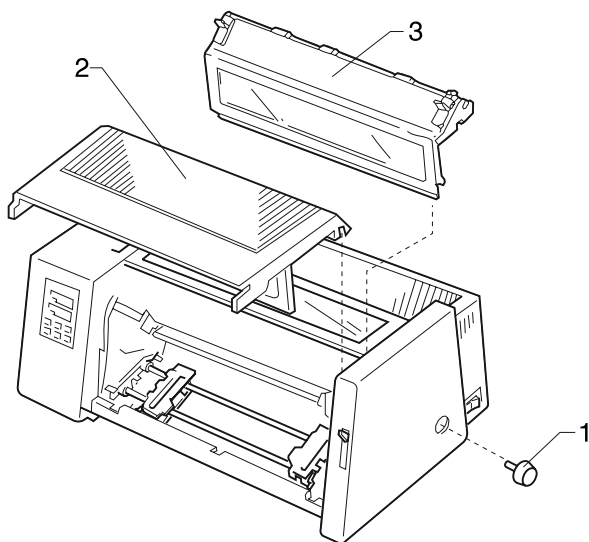

6. Release the two latches [9], and then remove the rear cover [3].
7. Set the paper select lever [4] to the cut sheet position.
8. Remove the two screws [8].
9. Stand the printer on its side. Insert a flat blade screwdriver into each of the five holes in the bottom cover and release the five latches that secure the top cover [5] to the bottom cover [6].

Note: The 2381 and 2391 have six cover latches that secure the top cover to the bottom cover.

10. While lifting the top cover slightly, disconnect the operator panel cable [7] from the sub logic board and then remove the top cover.

Reinstallation Note:

- Be sure that the operator panel cable is correctly aligned and inserted securely.

WARNING: Damage to the operator panel cable may cause failure of other electrical components of the printer. Be sure not to crimp or pinch this cable while reinstalling the top cover.

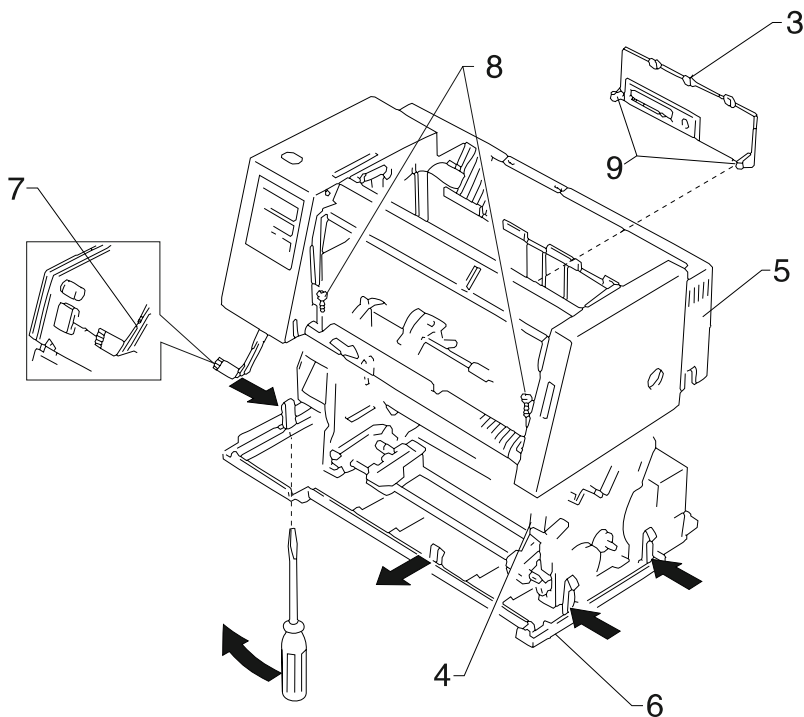

This Page Intentionally Blank.

Top of Form Sensor, Sensor Flag And Spring Removal

1. Remove the tractor assembly
see “Push Tractor Assembly Removal” on page 4-53.
2. Remove the top cover
see “Top Cover Removal” on page 4-61.
3. Remove the print unit and position the print unit on its front.
see “Print Unit Removal” on page 4-47.
4. Remove the screw [1] and the leaf spring [2].
5. Push the sensor [3] to the right to unsnap and remove it.

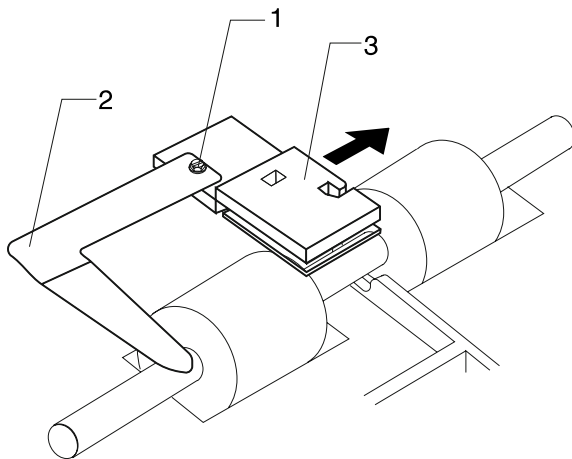

To Replace The Sensor Flag:

Unless necessary, do not replace the sensor flag when replacing the sensor.

1. With diagonal pliers, cut the post and two tabs [5] off as flush as possible.
2. Unsnap both ends of the sensor flag from the paper guide. Carefully remove the sensor flag spring [4] from the bottom end of the sensor flag.
3. Pivot the upper tip of the sensor flag downward through the open area just to the right of the center feed roll and lift the lower end of the flag until it becomes free.
4. The sensor flag spring hooks over the lower arm of the flag. Be sure the point of the sensor flag is kept in the paper path by the spring force. Be sure the leaf spring [2] is in contact with the lower feed roll shaft.

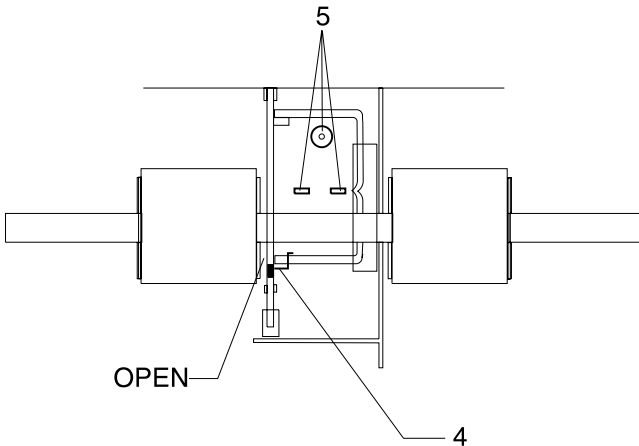

Upper Feed Roller Removal

1. Remove the top cover
see **"Top Cover Removal"** on page 4-61.
2. Disconnect the power supply cable from CN1 on the sub logic board. Remove the self-tapping screw that holds the sub logic board and the paper feed motor plate to the left side frame.
3. Remove the tractor idler gear [1] by inserting a small blade screwdriver between the tractor idler gear and the left side frame, and twisting. Bend the paper feed motor plate slightly to the left to remove the gear.
4. Release the latch and move the upper feed roller gear [3] to the left until it touches the paper feed motor plate. It will stay on the feed roller shaft.
5. Release the latch and remove the upper bushings [2]. Move the left bushing to the left; it will stay on the feed roller shaft.
6. Release tab **A**, and then remove the upper feed roller [4] in the direction indicated by the arrow. The upper feed roll gear and the left upper bushing will come off the feed roller as it is being removed.

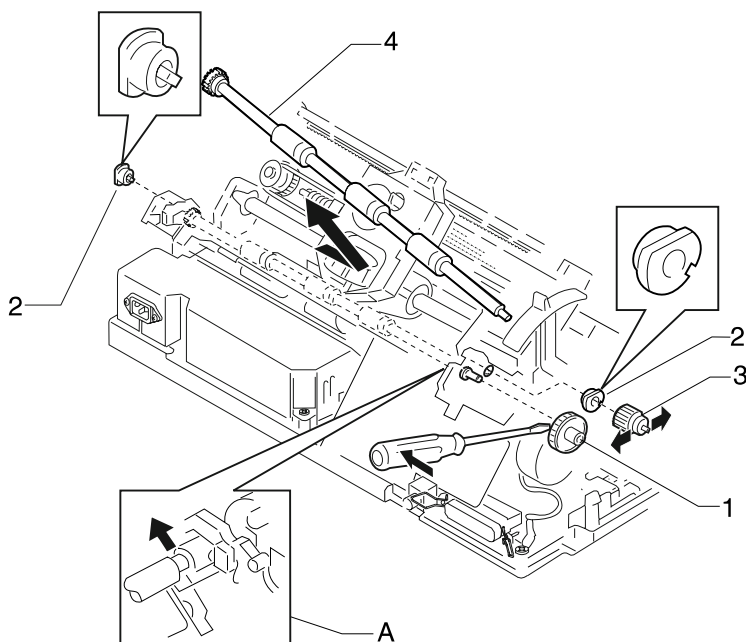

5. Connector Locations

This chapter shows the locations of specific parts of the printer.

Reference	Part Name
A	Form Thickness Lever
B	Paper Select Lever
C	Carrier Motor
D	Paper Feed Motor
E	Parallel Interface Connector
F	Main Logic Board
G	Sub Logic Board
H	Power Supply
I	Tractor Unit
J	Pull Tractor Actuator
K	Ribbon Cartridge
L	Ribbon Drive Rack Gear
M	Pinch Roller, Lower
N	Feed Roller, Lower
O	Printhead
P	Printhead Cables
Q	Carrier
R	Tension Pulley Plate
S	Feed Roller, Upper
T	Platen
U	Side Frame, Right
V	Side Frame, Left
W	Carrier Plate

Front View

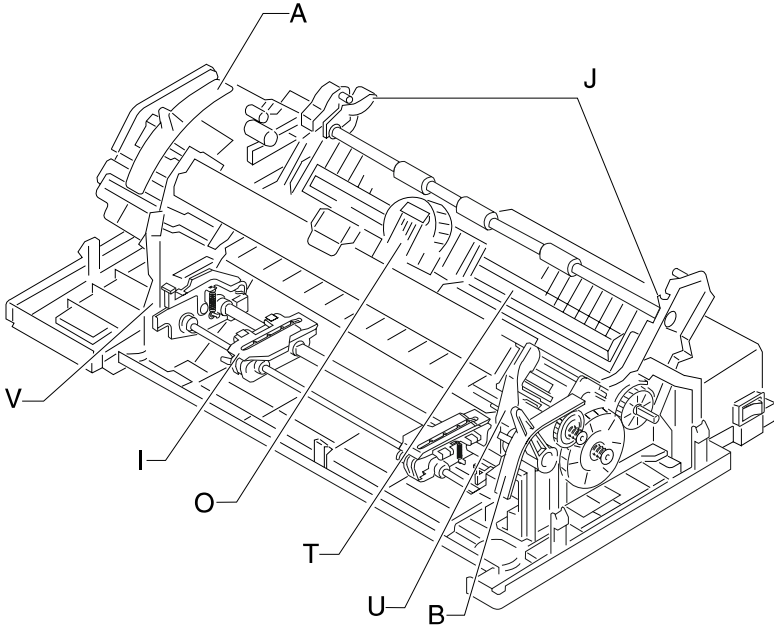

Tractor 2 Cable Connectors

The Tractor 2 cable is soldered to the board at CN1; there is no connector.

Connector	Mode
CN1-1	+26 V dc.
CN1-2	+ 26 V dc.
CN1-3	Frame GND.
CN1-4	Not Used.
CN1-5	+5 V dc.
CN1-6	Motor Common.
CN1-7	D-Set (Signal for Tractor 2 Plugged in).
CN1-8	Signal GND.
CN1-9	Motor Phase A; 0 V dc except when Tractor 2 motor is on.
CN1-10	Motor Phase B; +5 V dc when Tractor 2 not in use; 0 V dc when Tractor 2 is in use.
CN1-11	Not used.
CN1-12	Slider Home Sensor; + 5 V dc when open, 0 V dc when closed.
CN1-13	Tractor 2 In-Place Sensor; +5 V dc when open, 0 V dc when closed.

Wiring Diagrams

Block Diagram 238X-001

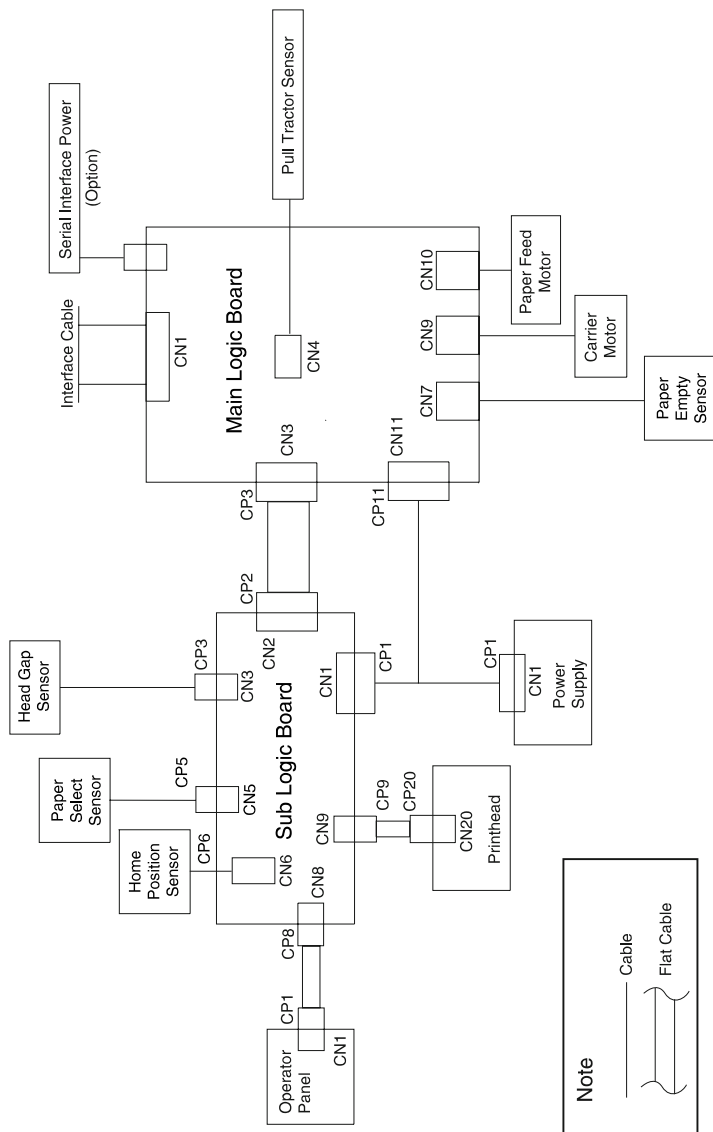

Connector Locations 5-5

Block Diagram 239X-001

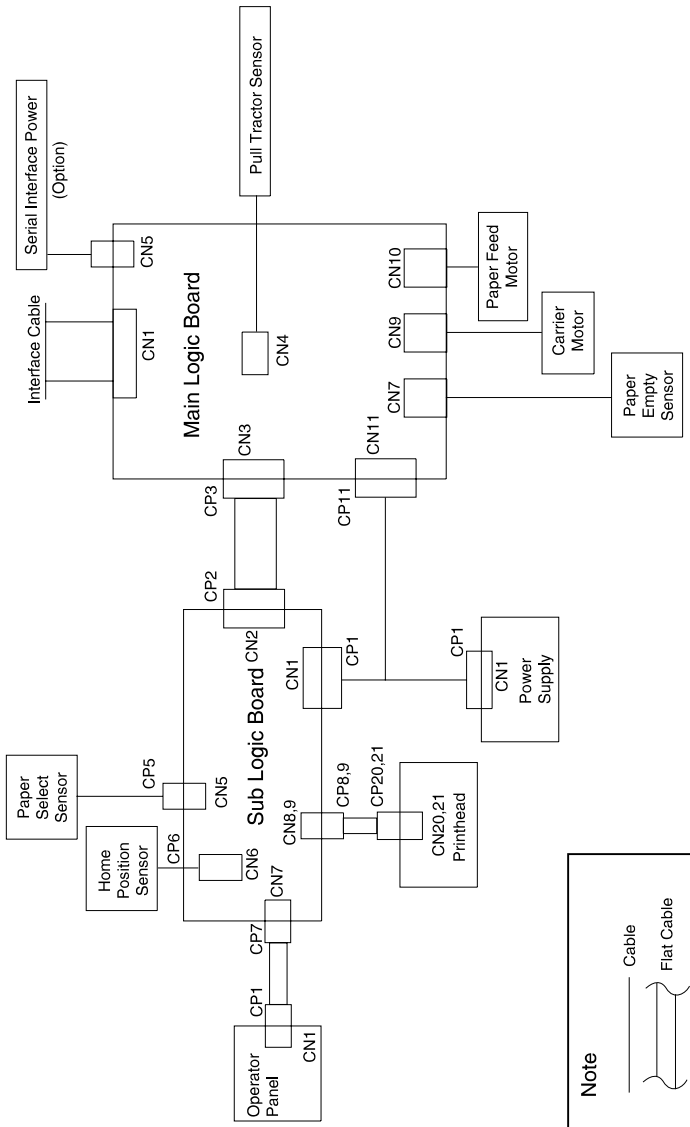

Block Diagram 238X-002

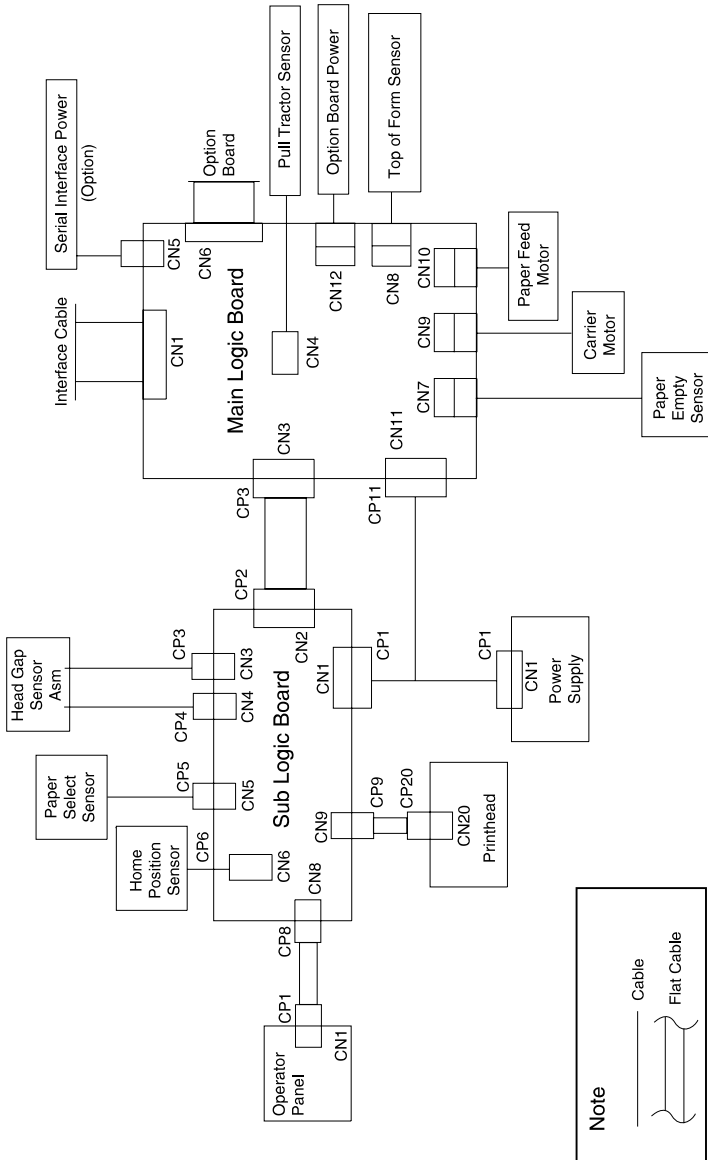

Connector Locations 5-7

Block Diagram 239X-002

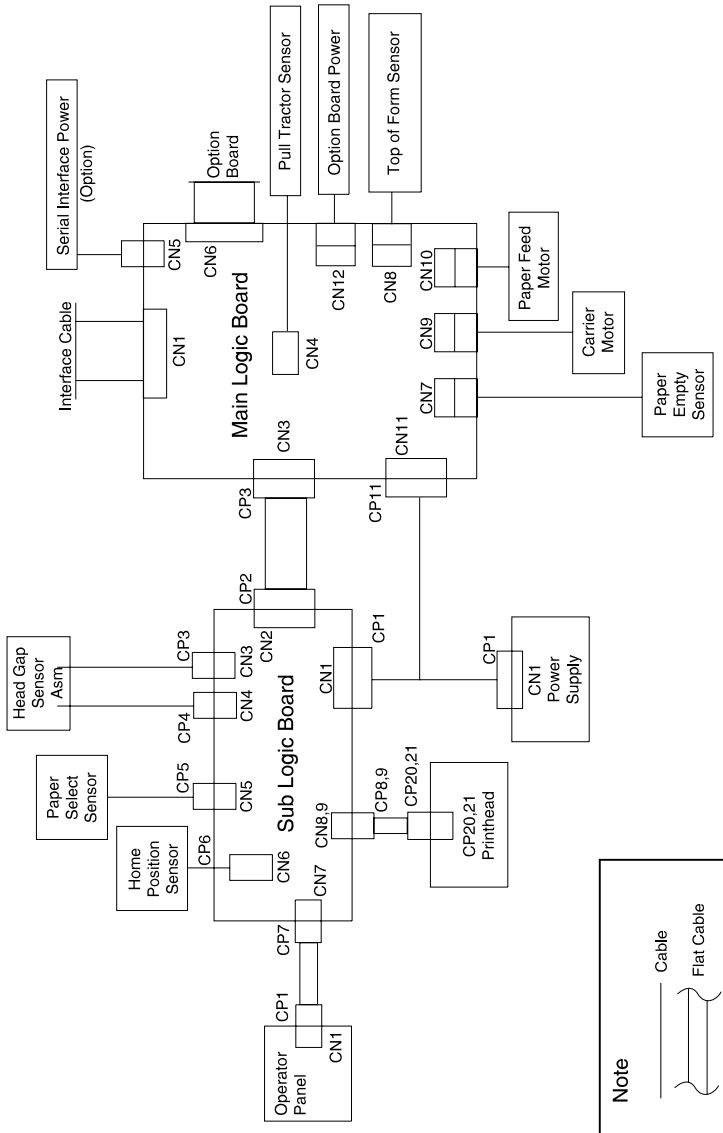

Block Diagram 239X-003

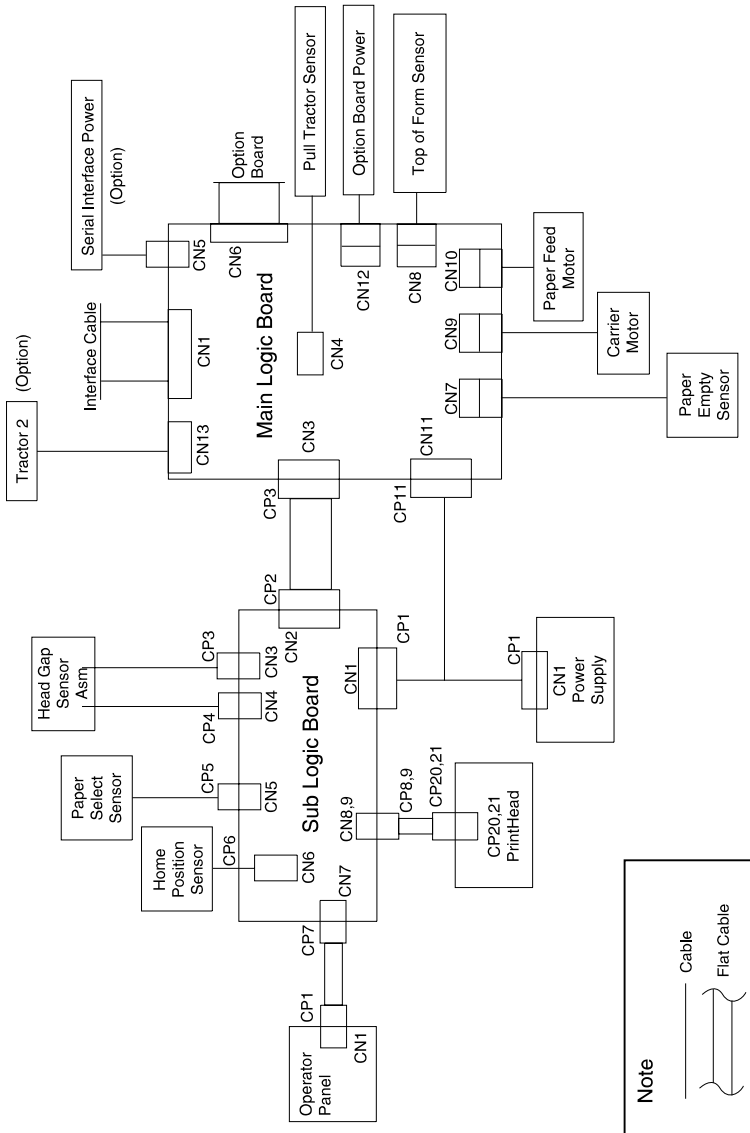

Signal Connections

Power Supply <--> Main Logic Board <--> Sub Logic Board

Power Supply		Main Logic Board		Sub Logic Board	
CN1		CN11		CN1	
Pin 1	SIGNAL GND	Pin 4	SIGNAL GND	Pin 4	SIGNAL GND
Pin 2	+5 V	Pin 3	+5 V	Pin 3	+5 V
Pin 3	POWER GND	Pin 2	POWER GND	Pin 2	POWER GND
Pin 4	+26 V	Pin 1	+26 V	Pin 1	+26 V

Main Logic Board <--> Parallel Interface Cable

Main Logic Board	
CN1	
Pin 1	-STROBE
Pin 2	DATA 0
Pin 3	DATA 1
Pin 4	DATA 2
Pin 5	DATA 3
Pin 6	DATA 4
Pin 7	DATA 5
Pin 8	DATA 6
Pin 9	DATA 7
Pin 10	-ACKNLG
Pin 11	BUSY
Pin 12	PE
Pin 13	SELECT
Pin 14	AUTO FEED
Pin 15	(Not Used)
Pin 16	SIGNAL GND
Pin 17	CHASSIS GND
Pin 18	(Not Used)
Pin 19	SIGNAL GND
Pin 20	SIGNAL GND
Pin 21	SIGNAL GND
Pin 22	SIGNAL GND
Pin 23	SIGNAL GND
Pin 24	SIGNAL GND
Pin 25	SIGNAL GND
Pin 26	SIGNAL GND
Pin 27	SIGNAL GND
Pin 28	SIGNAL GND
Pin 29	SIGNAL GND
Pin 30	SIGNAL GND
Pin 31	-INIT
Pin 32	-ERROR
Pin 33	SIGNAL GND
Pin 34	(Not Used)
Pin 35	(Not Used)
Pin 36	-SELECT IN

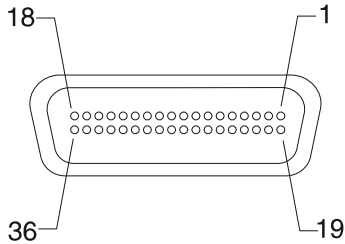

Main Logic Board <--> Sub Logic Board (Model - 001)

23XX-001		238X-001		239X-001	
Main Logic Board		Sub Logic Board		Sub Logic Board	
CN3		CN2		CN2	
Pin 1	SCLK	Pin 34	SCLK	Pin 34	SCLK
Pin 2	LEDD	Pin 33	LEDD	Pin 33	LEDD
Pin 3	SWO	Pin 32	SWO	Pin 32	SWO
Pin 4	SW LTCH	Pin 31	SW LTCH	Pin 31	SW LTCH
Pin 5	3SW	Pin 30	3SW	Pin 30	3SW
Pin 6	PUL CSF	Pin 29	PUL CSF	Pin 29	PUL CSF
Pin 7	HP	Pin 28	HP	Pin 28	HP
Pin 8	ASF	Pin 27	(Not Used)	Pin 27	(Not Used)
Pin 9	THRMO	Pin 26	(Not Used)	Pin 26	THRMO
Pin 10	HDCOM	Pin 25	(Not Used)	Pin 25	HDCOM
Pin 11	HD8	Pin 24	HD8	Pin 24	HD8
Pin 12	HD6	Pin 23	HD6	Pin 23	HD6
Pin 13	HD4	Pin 22	HD4	Pin 22	HD4
Pin 14	HD2	Pin 21	HD2	Pin 21	HD2
Pin 15	HD1	Pin 20	HD1	Pin 20	HD1
Pin 16	HD3	Pin 19	HD3	Pin 19	HD3
Pin 17	HD5	Pin 18	HD5	Pin 18	HD5
Pin 18	HD7	Pin 17	HD7	Pin 17	HD7
Pin 19	HD9	Pin 16	HD9	Pin 16	HD9
Pin 20	HD11	Pin 15	HD11	Pin 15	HD11
Pin 21	HD13	Pin 14	HD13	Pin 14	HD13
Pin 22	HD15	Pin 13	HD15	Pin 13	HD15
Pin 23	HD17	Pin 12	HD17	Pin 12	HD17
Pin 24	HD19	Pin 11	(Not Used)	Pin 11	HD19
Pin 25	HD21	Pin 10	HD21	Pin 10	HD21
Pin 26	HD23	Pin 9	(Not Used)	Pin 9	HD23
Pin 27	HD24	Pin 8	(Not Used)	Pin 8	HD24
Pin 28	HD22	Pin 7	(Not Used)	Pin 7	HD22
Pin 29	HD20	Pin 6	(Not Used)	Pin 6	HD20
Pin 30	HD18	Pin 5	HD18	Pin 5	HD18
Pin 31	HD16	Pin 4	HD16	Pin 4	HD16
Pin 32	HD14	Pin 3	HD14	Pin 3	HD14
Pin 33	HD12	Pin 2	HD12	Pin 2	HD12
Pin 34	HD10	Pin 1	HD10	Pin 1	HD10

Main Logic Board <--> Sub Logic Board (Model - 002, 003)

23XX-002, 003		238X-002, 003		239X-002, 003	
Main Logic Board		Sub Logic Board		Sub Logic Board	
CN3		CN2		CN2	
Pin 1	SCLK	Pin 28	SCLK	Pin 34	SCLK
Pin 2	LEDD	Pin 27	LEDD	Pin 33	LEDD
Pin 3	SWD	Pin 26	SWD	Pin 32	SWD
Pin 4	SW LTCH	Pin 25	SW LTCH	Pin 31	SW LTCH
Pin 5	GAP SW	Pin 24	GAP SW	Pin 30	GAP SW
Pin 6	PUL CSF	Pin 23	PUL CSF	Pin 29	PUL CSF
Pin 7	HP	Pin 22	HP	Pin 28	HP
Pin 8	THRMO	Pin 21	THRMO	Pin 27	THRMO
Pin 9	HD8	Pin 20	HD8	Pin 26	HD8
Pin 10	HD6	Pin 19	HD6	Pin 25	HD6
Pin 11	HD4	Pin 18	HD4	Pin 24	HD4
Pin 12	HD2	Pin 17	HD2	Pin 23	HD2
Pin 13	HD1	Pin 16	HD1	Pin 22	HD1
Pin 14	HD3	Pin 15	HD3	Pin 21	HD3
Pin 15	HD5	Pin 14	HD5	Pin 20	HD5
Pin 16	HD7	Pin 13	HD7	Pin 19	HD7
Pin 17	HD9	Pin 12	HD9	Pin 18	HD9
Pin 18	HD11	Pin 11	HD11	Pin 17	HD11
Pin 19	HD13	Pin 10	HD13	Pin 16	HD13
Pin 20	HD15	Pin 9	HD15	Pin 15	HD15
Pin 21	HD17	Pin 8	HD17	Pin 14	HD17
Pin 22	HD18	Pin 7	HD18	Pin 13	HD18
Pin 23	HD16	Pin 6	HD16	Pin 12	HD16
Pin 24	HD14	Pin 5	HD14	Pin 11	HD14
Pin 25	HD12	Pin 4	HD12	Pin 10	HD12
Pin 26	HD10	Pin 3	HD10	Pin 9	HD10
Pin 27	HD21	Pin 2	HD21	Pin 8	HD21
Pin 28	MSW	Pin 1	MSW	Pin 7	MSW
Pin 29	HDCOM			Pin 6	HDCOM
Pin 30	HD19			Pin 5	HD19
Pin 31	HD23			Pin 4	HD23
Pin 32	HD24			Pin 3	HD24
Pin 33	HD22			Pin 2	HD22
Pin 34	HD20			Pin 1	HD20

Main Logic Board <--> Pull Tractor Sensor

CN4	
Pin 1	PUL TRA
Pin 2	SIGNAL GND

Main Logic Board <--> Serial Interface Card (option)

CN5	
Pin 1	+5 V
Pin 2	SIGNAL GND

Main Logic Board <--> Paper Empty Sensor

CN7	
Pin 1	PE1P
Pin 2	PE1
Pin 3	SIGNAL GND

Main Logic Board <--> Top of Form Sensor (23XX-002)

CN8	
Pin 1	TOFP
Pin 2	TOF
Pin 3	SIGNAL GND

Main Logic Board <-->Carrier Motor

CN9	
Pin 1	CAD
Pin 2	CAC
Pin 3	CAB
Pin 4	CAA
Pin 5	CACOMB
Pin 6	CACOMA

Main Logic Board <--> Paper Feed Motor

CN10	
Pin 1	LFD
Pin 2	LFC
Pin 3	LFB
Pin 4	LFA
Pin 5	LFCOMB
Pin 6	LFCOMA (Not used on Model 003)
Pin 7	(Not Used)

Sub Logic Board (238X-001) <--> Head Gap Sensor

CN3	
Pin 1	Aid Port
Pin 2	Gap

Sub Logic Board (238X-002, 003) <--> Head Gap Pos 1 to 2

CN3	
Pin 1	SIGNAL GND
Pin 2	GS2

Sub Logic Board (238X-002, 003) <--> Head Gap Pos 3 to 4

CN4	
Pin 1	+5 V
Pin 2	GS1

Sub Logic Board <--> Paper Select Sensor

CN5	
Pin 1	F/T
Pin 2	SIGNAL GND

Sub Logic Board <--> Home Position Sensor

CN6	
Pin 1	HP
Pin 2	SIGNAL GND

Sub Logic Board <--> Operator Panel (23XX-001)

Sub Logic Board		Operator Panel	
CN7(239X) CN8(238X)		CN1	
Pin 1	SIGNAL GND	Pin 9	SIGNAL GND
Pin 2	SIGNAL GND	Pin 8	SIGNAL GND
Pin 3	+5 V	Pin 7	+5 V
Pin 4	LEDD	Pin 6	LEDD
Pin 5	SW LTCH	Pin 5	SW LTCH
Pin 6	SWD	Pin 4	SWD
Pin 7	SIGNAL GND	Pin 3	SIGNAL GND
Pin 8	SCLK	Pin 2	SCLK
Pin 9	+5 V	Pin 1	+5 V

Sub Logic Board <--> Operator Panel (23XX-002, 003)

Sub Logic Board		Operator Panel	
CN7(239X) CN8(238X)		CN1	
Pin 1	SIGNAL GND	Pin 10	SIGNAL GND
Pin 2	SIGNAL GND	Pin 9	SIGNAL GND
Pin 3	+5 V	Pin 8	+5 V
Pin 4	LEDD	Pin 7	LEDD
Pin 5	SW LTCH	Pin 6	SW LTCH
Pin 6	SWD	Pin 5	SWD
Pin 7	SIGNAL GND	Pin 4	SIGNAL GND
Pin 8	SCLK	Pin 3	SCLK
Pin 9	+5 V	Pin 2	+5 V
Pin 10	MSW	Pin 1	MSW

Sub Logic Board (238X) <--> Printhead

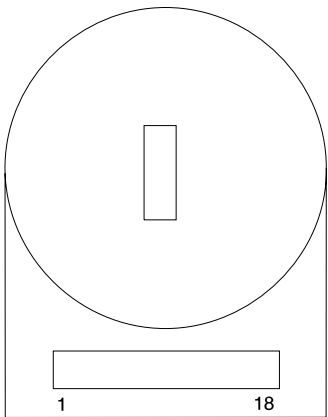
CN3		Printhead
Pin 1	HDU6	
Pin 2	HDU8	
Pin 3	HDD4	
Pin 4	HDD2	
Pin 5	HDD6	
Pin 6	HDU2	
Pin 7	HDU4	
Pin 8	HDD8	
Pin 9	HDD9	
Pin 10	HDU1	
Pin 11	HDD5	
Pin 12	HDD1	
Pin 13	HDD7	
Pin 14	HDD3	
Pin 15	HDU5	
Pin 16	HDU9	
Pin 17	HDU3	
Pin 18	HDU7	

Sub Logic Board (239X) <--> Printhead

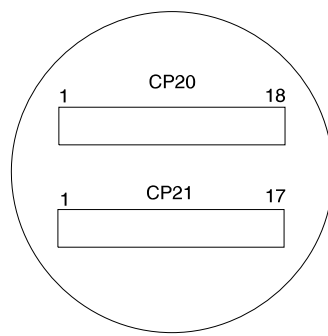
CN8		CN9		Printhead
Pin 1	HDP10	Pin 1	HDP20	
Pin 2	HDP8	Pin 2	HDP18	
Pin 3	HDP12	Pin 3	HDP22	
Pin 4	HDP6	Pin 4	HDP16	
Pin 5	HDP14	Pin 5	HDP24	
Pin 6	HDP4	Pin 6	COM	
Pin 7	COM	Pin 7	THRMO	
Pin 8	HDP2	Pin 8	COM	
Pin 9	COM	Pin 9	THRMO	
Pin 10	HDP1	Pin 10	COM	
Pin 11	COM	Pin 11	HDP23	
Pin 12	HDP3	Pin 12	COM	
Pin 13	COM	Pin 13	HDP21	
Pin 14	HDP5	Pin 14	COM	
Pin 15	HDP13	Pin 15	HDP19	
Pin 16	HDP7	Pin 16	HDP15	
Pin 17	HDP11	Pin 17	HDP17	
Pin 18	HDP9			

Connector Locations

Main Logic Board 23XX-001

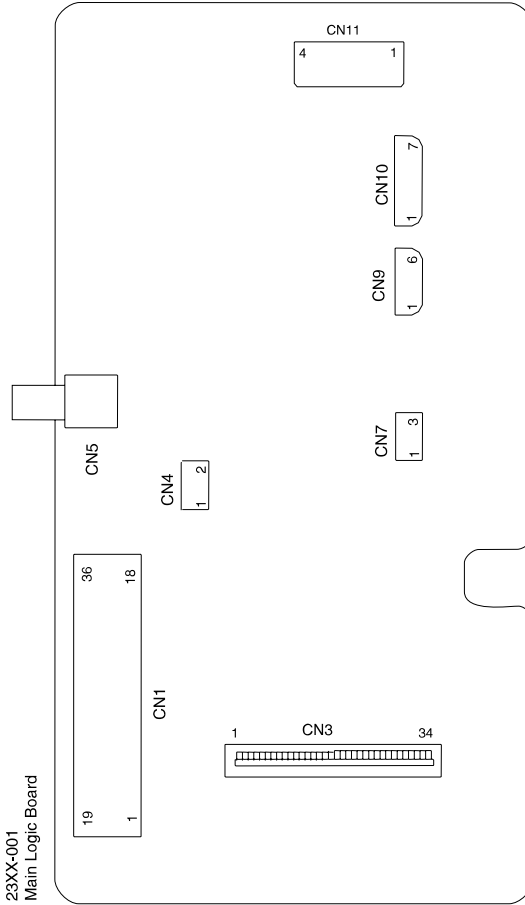

Main Logic Board 23XX-002

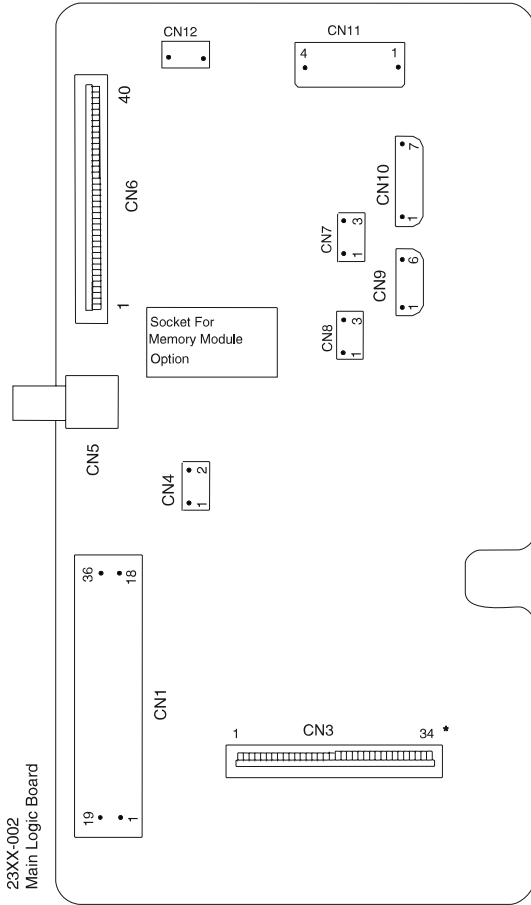

* 28 for 238X-002

Main Logic Board 23XX-003

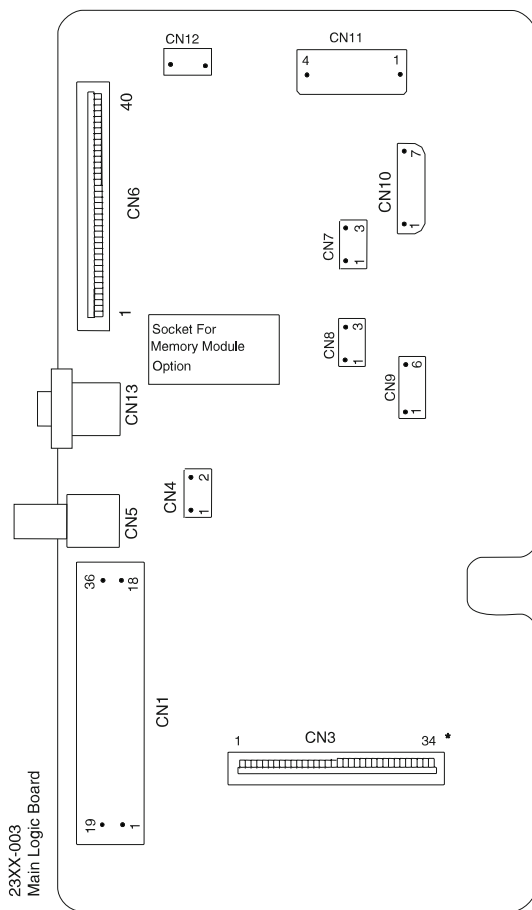

* 28 for 238X-003

Sub Logic Boards

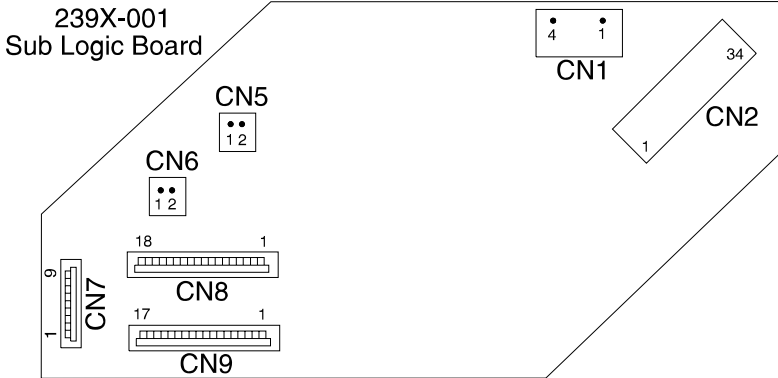
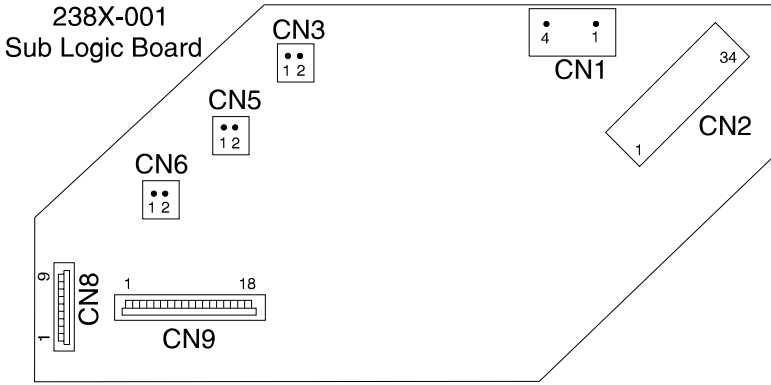

238X-002, 003
Sub Logic Board

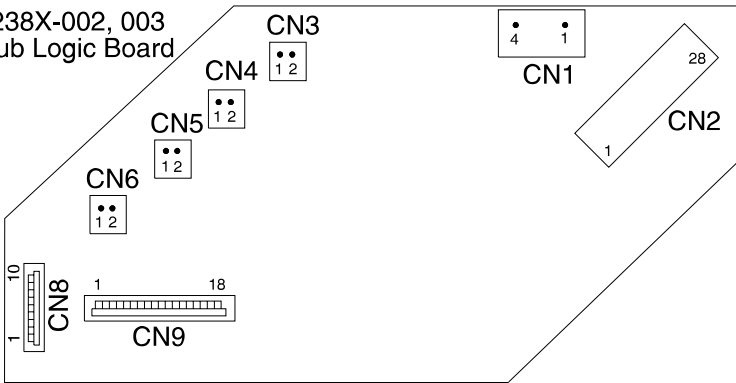

239X-002, 003
Sub Logic Board

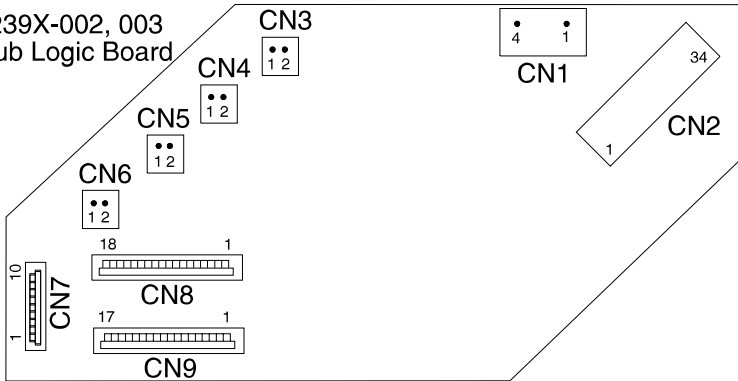

Power Supply

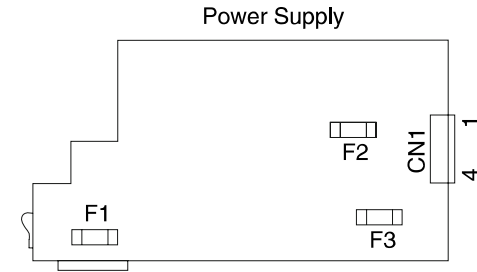

23XX-002, 003 Printers have jumper in place of F3

Serial Interface Option To Main Logic Board
CN1 (parallel connector)

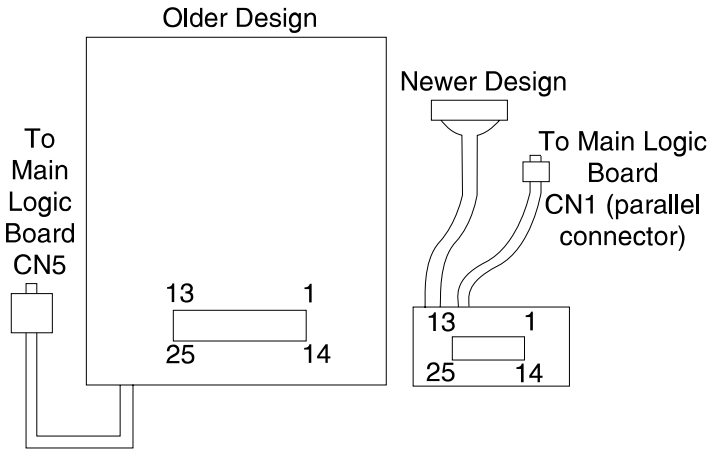

Connector Locations 5-25

Operator Panel

Operator Panel

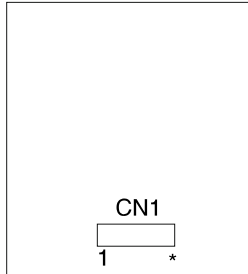

*9 for 23XX-001
10 for 23XX-002, 003

6. Preventive Maintenance

This chapter describes procedures for printer preventive maintenance. Following these recommendations can help prevent problems and maintain optimum performance.

Lubrication

Warning: Petroleum-based lubricants can attack polycarbonate parts causing premature failure. Use only mineral oil-based lubricant.

The following parts should be lubricated when replaced:

- Oil felt (carrier block)
- Tractor unit
- Side frame (left)
- Side frame (right)
- Pinch roller (lower)
- Pinch roller spring (left)
- Pinch roller spring (center)
- Pinch roller spring (right)
- Paper separator

Specified Lubricants

- Oil - P/N 1280443
- Approved equivalents:
 - Mobil DTE27
 - Shell Tellus 100
 - Fuchs Renolin MR30
- Grease - P/N 6934659
- Approved equivalent:
 - Mobil 28

Lubrication Points

Oil

Lubricate the following contact positions:

- Oil Felt (carrier block)
- Tractor Shaft

Grease

- Lubricate the following contact positions:
- Side Frame (Left) and Pull Tractor Idler Gear
- Side Frame (Left) and Gear B
- Side Frame (Left) and Idler Gear
- Side Frame (Right) and Shift Gear
- Side Frame (Right) and ASF Idler Gear
- Side Frame (Right) and ASF Drive Gear
- Pinch Roller (Lower) and Pinch Roller Spring (Left)
- Pinch Roller (Lower) and Pinch Roller Spring (Center)
- Pinch Roller (Lower) and Pinch Roller Spring (Right)
- Pinch Roller (Lower) and Paper Separator
- ASF Side Frame (Right) and Joint Gear
- ASF Side Frame (Right) and Idler Gear
- ASF Side Frame (Right) and Idler Gear
- ASF Side Frame (Right) and Combination Lock Mechanism
- ASF Side Frame (Right) and Feed Roll Gear (Lower)
- ASF Side Frame (Right) and Feed Roll Gear (Upper)
- ASF Side Frame (Left) and Upper Feed Roll Shaft
- ASF Pick-up Roller Shaft and Roller Bushing (Left)
- ASF Pick-up Roller Shaft and Roller Bushing (Right)

Lubrication Points (Oil)

The oil felt [1] in the carrier block.

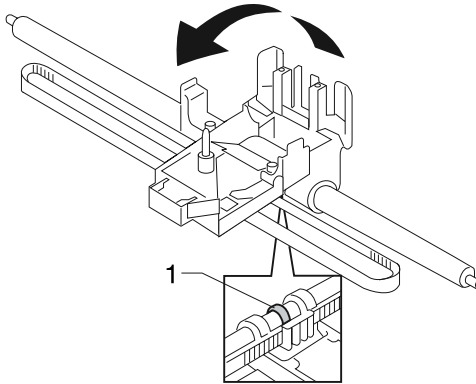

The tractor shaft [1].

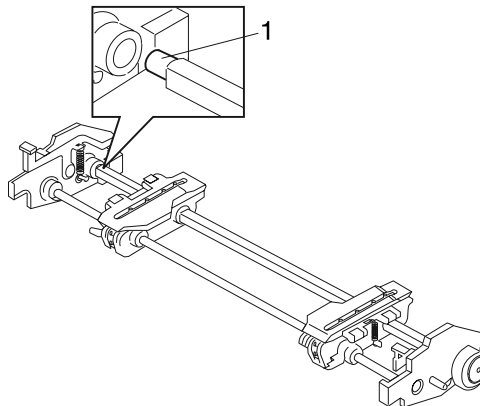

Lubrication Points (Grease)

Gear mounting studs on the right side frame [2].

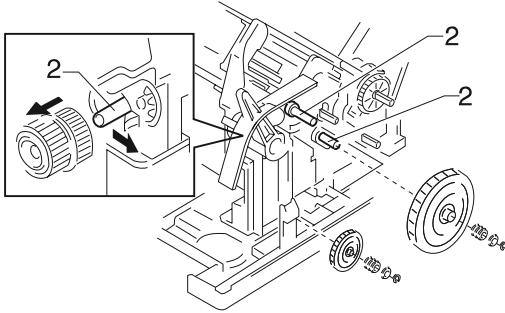

The lower pinch roller [2].

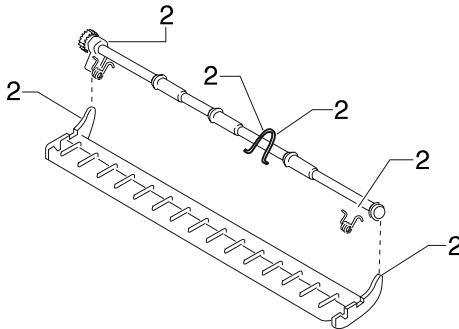

Lubrication Points (Grease) Continued

Gear mounting studs on the left side frame [2].

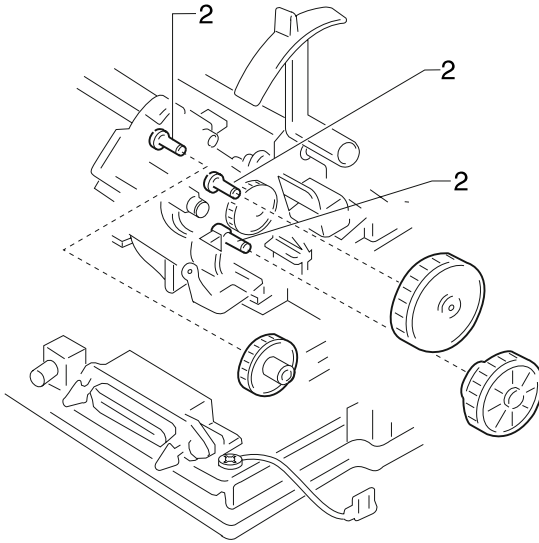

Lubrication Points (Grease) Continued

Gear mounting studs on the left ASF side frame [2].

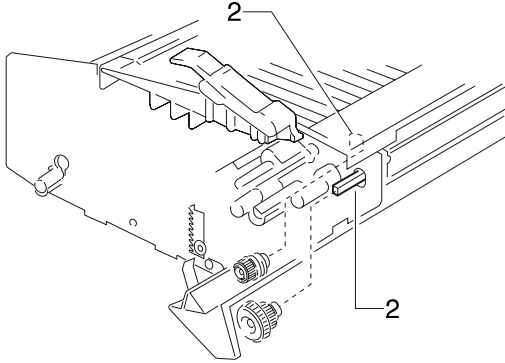

Gear mounting studs on the right ASF side frame [2].

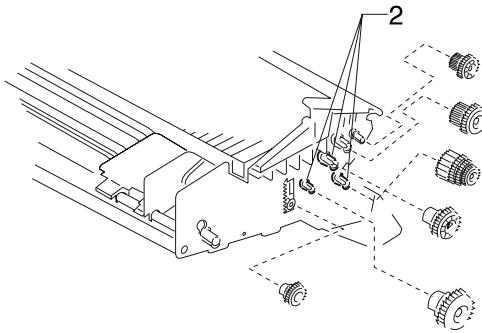

7. Parts Catalog

How To Use This Parts Catalog

- **SIMILAR ASSEMBLIES:** If two assemblies contain a majority of identical parts, they are broken down on the same list. Common parts are shown by one index number. Parts peculiar to one or the other of the assemblies are listed separately and identified by description.
- **AR: (As Required)** in the Units column indicates that the quantity is not the same for all machines.
- **NP: (Non-Procurable)** in the Units column indicates that the part is non-procurable and that the individual parts or the next higher assembly should be ordered.
- **NR: (Not Recommended)** in the Units column indicates that the part is procurable but not recommended for field replacement, and that the next higher assembly should be ordered.
- **R: (Restricted)** in the Units column indicates that the part has a restricted availability.
- **NS: (Not Shown)** in the Asm-Index column indicates that the part is procurable but is not pictured in the illustration.
- **PP: (Parts Packet)** in the Description column indicates that the part is contained in a parts packet.

Assembly 1: Major Components

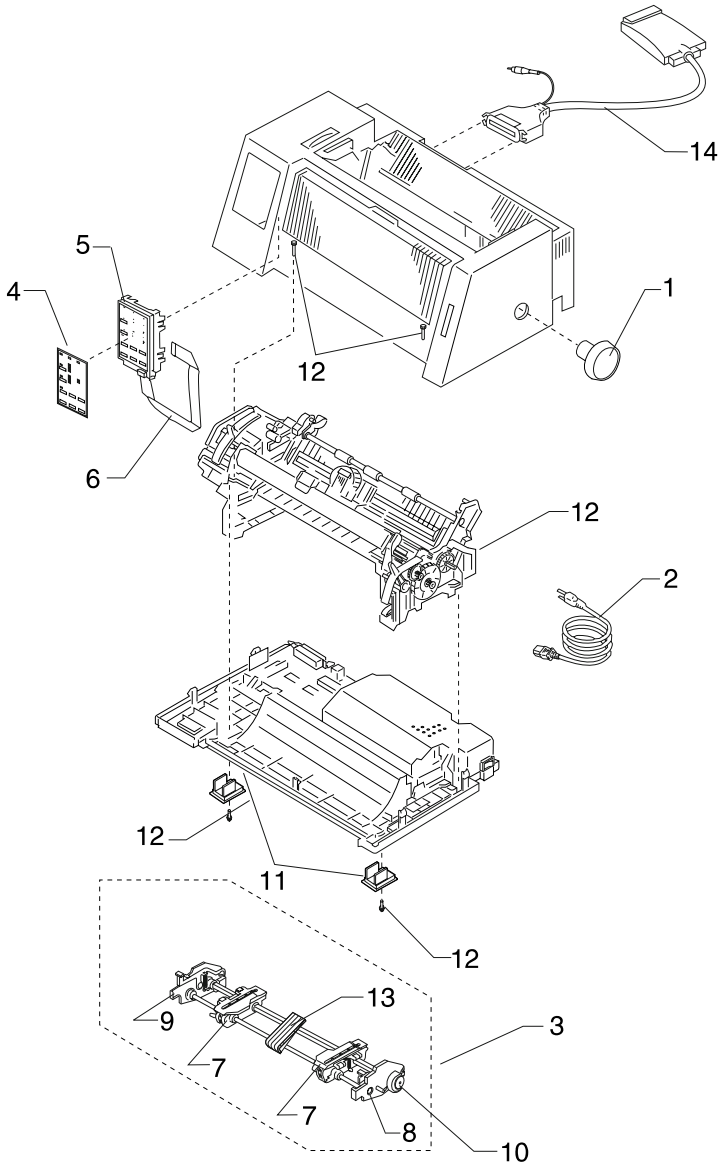

Asm-Index	Part Number	Description
1 -1	79F4784	Paper Advance Knob (23XX-001 and 2390 PS/1)
2	79F4757	Linecord (U.S., Canada, AFE (LV), Saudi Arabia (LV), Central and South America, Mexico)
2	1339519	Linecord (United Kingdom, Malaysia, and Singapore)
2	1339520	Linecord (Germany, France, Spain, Norway, Finland, The Netherlands, Austria, Belgium, Brazil, Greece, Luxembourg, Portugal, Sweden, Turkey, Saudi Arabia (HV), Indonesia)
2	1339525	Linecord (Denmark)
2	1339524	Linecord (Italy and Chile)
2	1339521	Linecord (Israel)
2	1339523	Linecord (South Africa)
2	1339522	Linecord (Switzerland)
2	1339518	Linecord (Australia, New Zealand, Argentina, Paraguay)
2	1339517	Linecord (Peru)
3	79F4791	Tractor Unit (2380-001 & 2390-001)
3	79F4827	Tractor Unit (2381-001 & 2391-001)
3	1333153	Tractor Unit (2380-002, 003 2390-002, 003)
3	1333157	Tractor Unit (2381-002, 003 2391-002, 003)
4	79F4851	Operator Panel Overlay Pack (238X-001)
4	79F4846	Operator Panel Overlay Pack (239X-001)
4	1333212	Operator Panel Overlay Pack (238X-002)
4	1333213	Operator Panel Overlay Pack (239X-002)
4	11A3300	Operator Panel Overlay Pack (238X-003)
4	11A3301	Operator Panel Overlay Pack (239X-003)
5	79F4785	Operator Panel Asm with English Overlay (238X-001)
5	79F4816	Operator Panel Asm with English Overlay (239X-001)
5	1333214	Operator Panel Asm with English Overlay (238X-002)
5	1333215	Operator Panel Asm with English Overlay (239X-002)
5	11A3302	Operator Panel Asm with English Overlay (238X-003)
5	11A3303	Operator Panel Asm with English Overlay (239X-003)
6	95F5314	Operator Panel Flat Cable (23XX-001)
6	1333216	Operator Panel Flat Cable (23XX-002)

Assembly 1: Major Components (Continued)

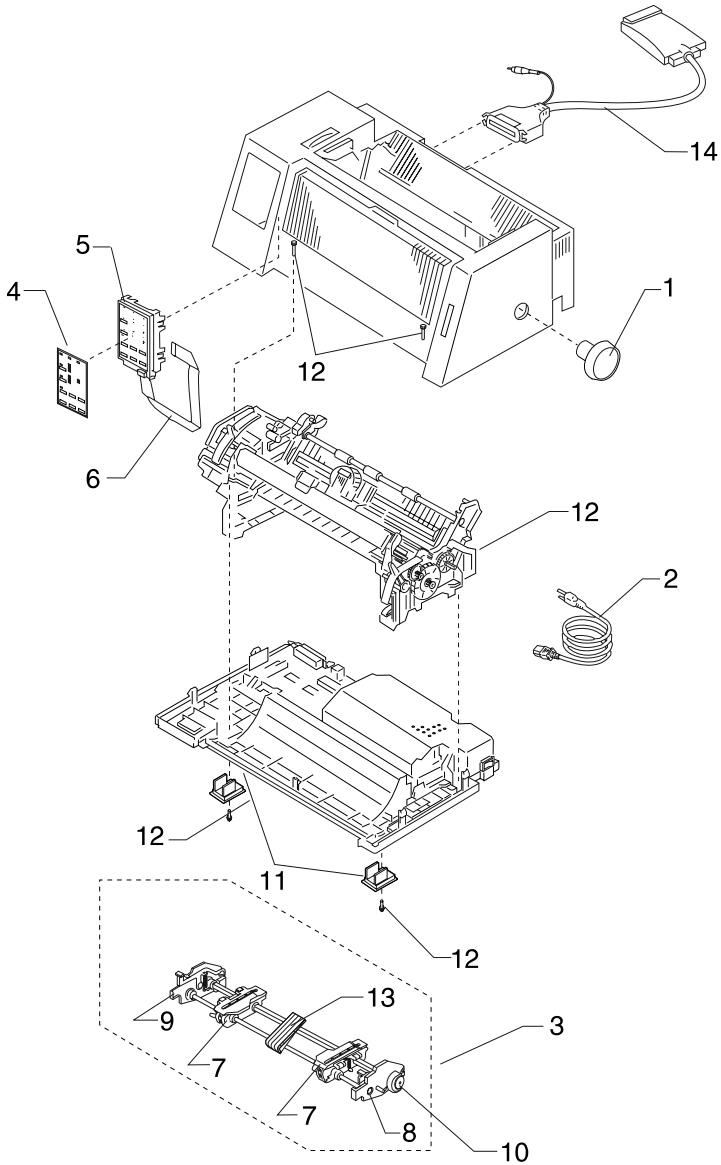

Asm-Index	Part Number	Description
1-7	79F4838	Tractors (L and R) (23XX-001)
7	1333160	Tractors (L and R) (23XX-002, 003)
8	79F4837	Tractor Side Frame (R) (23XX-001)
8	1333159	Tractor Side Frame (R) (23XX-002, 003)
9	79F4836	Tractor Side Frame (L) (23XX-001)
9	1333158	Tractor Side Frame (L) (23XX-002, 003)
10	79F4810	Gear and Bushing Kit (238X-001, 002)
10	79F4806	Gear and Bushing Kit (239X-001, 002)
10	11A3272	Gear and Bushing Kit (238X-003)
10	11A3273	Gear and Bushing Kit (239X-003)
11	79F4770	Side Frame Locking Plates
12	79F4860	Screw, Washer & Clip Kit (23XX-001)
12	1333219	Screw, Washer & Clip Kit (23XX-002)
12	11A3344	Screw, Washer & Clip Kit (23XX-003)
13	79F4830	Tractor Paper Support (2381 & 2391)
14	1368701	Serial Interface Adapter

Assembly 2: Covers

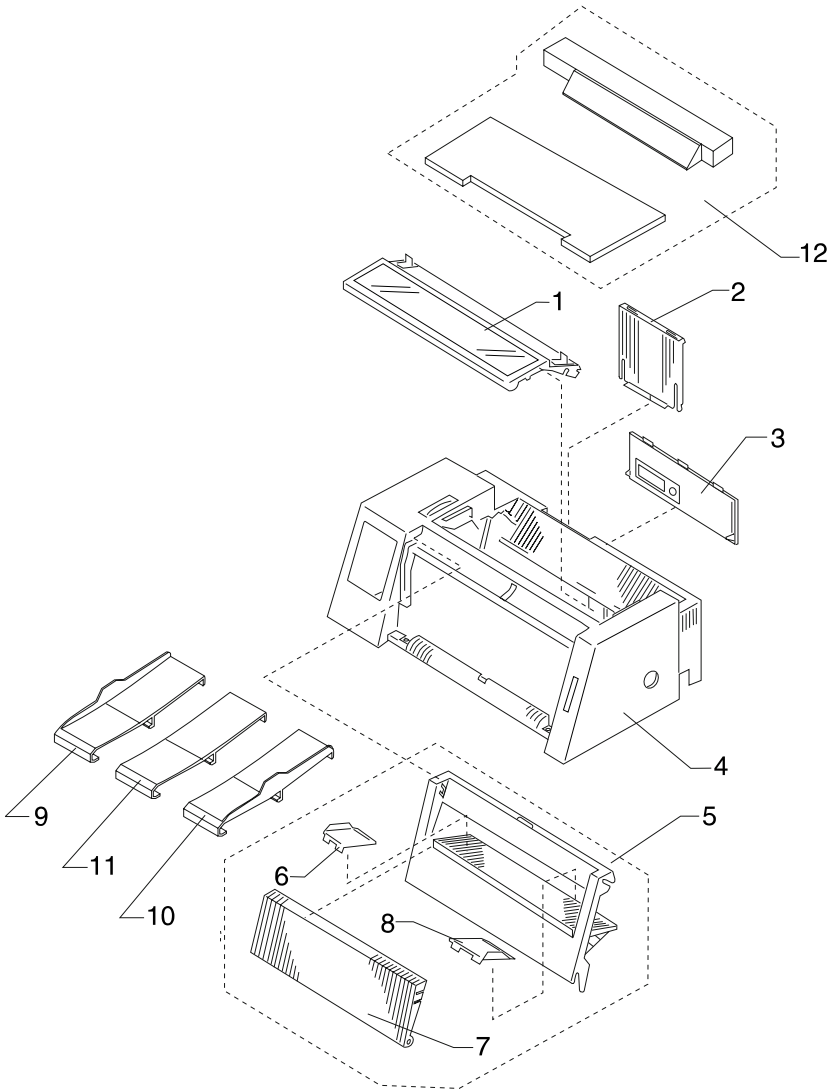

Asm-Index	Part Number	Description
2 -1	79F4780	Ribbon Access Cover Unit (2380-001 & 2390-001)
1	79F4826	Ribbon Access Cover Unit (2381-001 & 2391-001)
1	1333151	Ribbon Access Cover Unit (2380-002, 003 2390-002, 003)
1	1333156	Ribbon Access Cover Unit (2381-002, 003 2391-002, 003)
2	79F4782	Paper Stand
3	79F4781	Rear Cover (23XX-001, 002)
3	11A3304	Rear Cover (23XX-003)
4	79F4856	Top Cover (U.S., Canada and AFE (LV)) 2380-001
4	79F4857	Top Cover (U.S., Canada and AFE (LV)) 2381-001
4	79F4858	Top Cover (U.S., Canada and AFE (LV)) 2390-001
4	79F4859	Top Cover (U.S., Canada and AFE (LV)) 2391-001
4	1180844	Top Cover (2390 PS/1)
4	79F4852	Top Cover (EMEA and AFE (HV)) 2380-001
4	79F4853	Top Cover (EMEA and AFE (HV)) 2381-001
4	79F4854	Top Cover (EMEA and AFE (HV)) 2390-001
4	79F4855	Top Cover (EMEA and AFE (HV)) 2391-001
4	11A3305	Top Cover (with logo kit 2380-002, 003 2390-002, 003)
4	11A3306	Top Cover (with logo kit 2381-002, 003 2391-002, 003)
5	79F4778	Front Cover Unit (2380-001 & 2390-001)
5	79F4824	Front Cover Unit (2381-001 & 2391-001)
5	1333150	Front Cover Unit (2380-002, 003 & 2390-002, 003)
5	1333155	Front Cover Unit (2381-002, 003 & 2391-002, 003)
6	79F4783	L. H. Paper Guide (23XX-001)
6	1333152	L. H. Paper Guide (23XX-002, 003)
7	79F4779	Front Guide Cover (2380 & 2390)
7	79F4825	Front Guide Cover (2381 & 2391)
8	1180863	R. H. Paper Guide (23XX-001)
8	1333167	R. H. Paper Guide (23XX-002, 003)

Assembly 2: Covers (Continued)

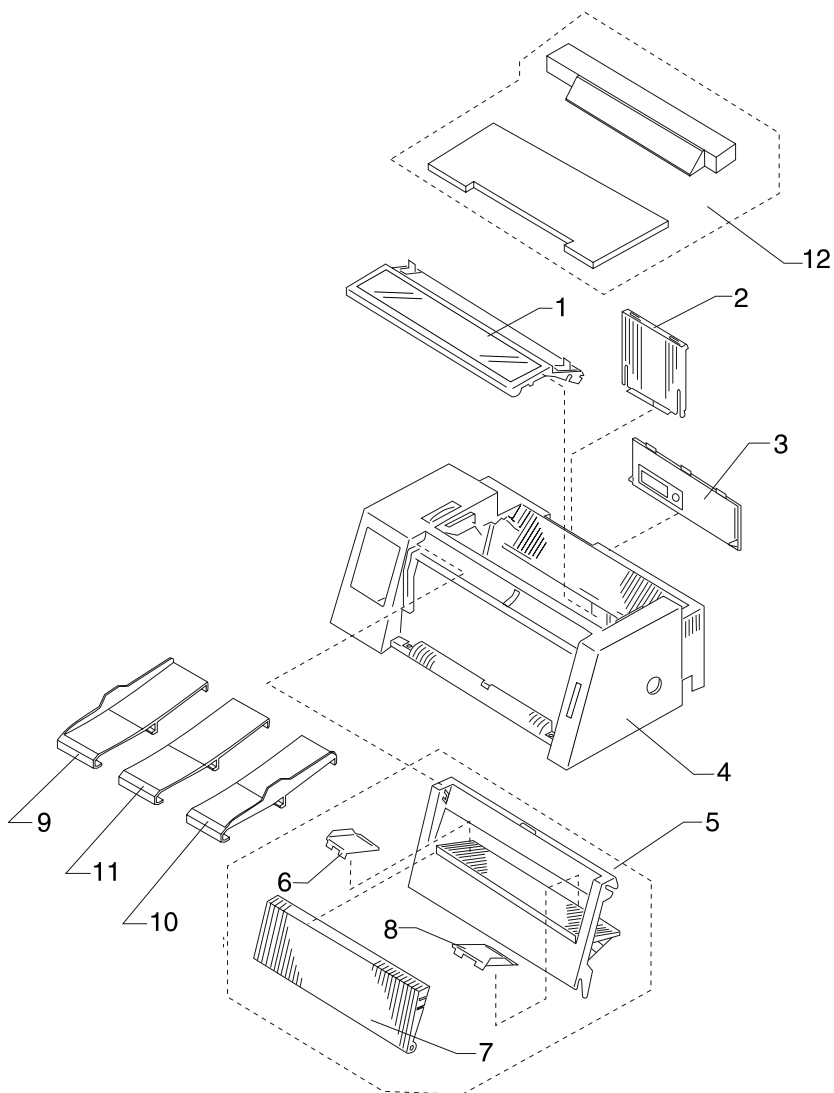

9	1180860	Left Extended Paper Guide (Option) (23XX-001)
9	1333164	Left Extended Paper Guide (Option) (23XX-002, 003)
10	1180861	Right Extended Paper Guide (Option) (23XX-001)
10	1333165	Right Extended Paper Guide (Option) (23XX-002, 003)
11	1180862	Center Extended Paper Guide (Option) (23XX-001)
11	1333166	Center Extended Paper Guide (Option) (23XX-002, 003)
12	1332972	Acoustics Kit (Option) (2380 & 2390)
12	1332973	Acoustics Kit (Option) (2381 & 2391)

Assembly 3: Carrier

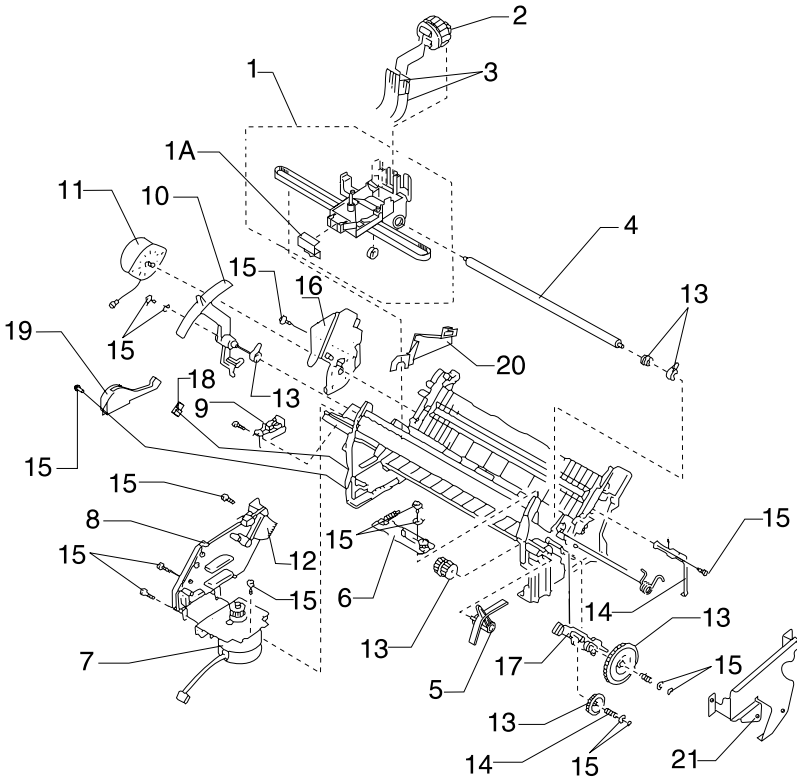

Asm-Index	Part Number	Description
3 -1	79F4796	Carrier Unit (2380-001)
1	79F4820	Carrier Unit (2381-001)
1	79F4848	Carrier Unit (2390-001)
1	79F4861	Carrier Unit (2391-001)
1	1333195	Carrier Unit (2380-002, 003)
1	1333196	Carrier Unit (2381-002, 003)
1	1333197	Carrier Unit (2390-002, 003)
1	1333198	Carrier Unit (2391-002, 003)
1A	1333234	Carrier Roller Set
2	79F4792	Printhead (2380 & 2381)
2	79F4818	Printhead (239X-001)
2	1333220	Printhead (239X-002, 003)
3	79F4793	Printhead Cable (2380)
3	79F4819	Printhead Cable (2381)
3	79F4828	Printhead Cable (2390)
3	79F4829	Printhead Cable (2391)
4	1180877	Carrier Shaft (2380 & 2390)
4	1180878	Carrier Shaft (2381 & 2391)
5	79F4814	Paper Select Lever (23XX-001)
5	1333154	Paper Select Lever (23XX-002, 003)
6	79F4805	Tension Pulley Plate Assembly (23XX-001, 002)
6	11A3346	Tension Pulley Plate Assembly (23XX-003)
7	11A3186	Carrier Motor Assembly (238X-001)
7	1333221	Carrier Motor Assembly (238X-002)
7	79F4817	Carrier Motor Assembly (239X-001)
7	1333222	Carrier Motor Assembly (239X-002)
7	11A3313	Carrier Motor Assembly (23XX-003)
8	79F4754	Sub Logic Board Assembly (238X-001)
8	1333223	Sub Logic Board Assembly (238X-002, 003)
8	79F4764	Sub Logic Board Assembly (239X-001)
8	1333224	Sub Logic Board Assembly (239X-002, 003)

Assembly 3: Carrier (Continued)

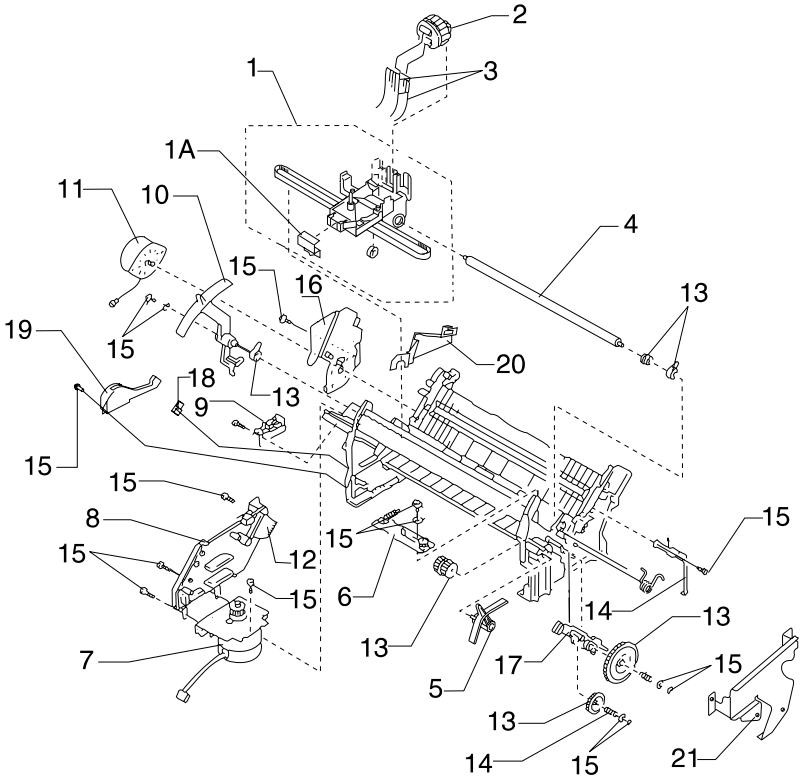

Asm-Index	Part Number	Description
3- 9	79F4795	Home Position Sensor (23XX-001)
9	1333236	Home Position Sensor (23XX-002, 003)
10	1180988	Form Thickness Lever (23XX-001)
10	1333168	Form Thickness Lever (23XX-002, 003)
11	79F4789	Paper Feed Motor (23XX-001, 002)
11	11A3307	Paper Feed Motor (23XX-003)
12	1333225	Short Flexible Cable (238X-002, 003)
12	95F5315	Short Flexible Cable (All others)
13	79F4810	Gear and Bushing Kit (238X-001, 002)
13	79F4806	Gear and Bushing Kit (239X-001, 002)
13	11A3272	Gear and Bushing Kit (238X-003)
13	11A3273	Gear and Bushing Kit (239X-003)
14	79F4811	Spring Kit (23XX-001, 2381-002, 2391-002)
14	1333228	Spring Kit (2380-002 & 2390-002)
14	11A3308	Spring Kit (2380-003 & 2390-003)
14	11A3309	Spring Kit (2381-003 & 2391-003)
15	79F4860	Screw, Washer and Clip Kit (23XX-001)
15	1333219	Screw, Washer and Clip Kit (23XX-002)
15	11A3344	Screw, Washer and Clip Kit (23XX-003)
NS	1333229	ESD Kit (238X-002, 003)
NS	1333230	ESD Kit (239X-002, 003)
16	79F4797	Feed Motor Plate
17	79F4800	Release Slider Cam (23XX-001, 23XX-002)
17	11A3310	Release Slider Cam (23XX-003)
17A	11A3311	Sub Slider Cam (23XX-003)
18	79F4794	Head Gap Sensor (238X-001)
19	1333237	Head Gap Sensor Assembly (23XX-002, 003)
20	1333235	Support Plate, left side (23XX-002, 003)
21	11A3271	Shaft Support Plate (23XX-003)

Assembly 4: Paper Guide / Platen / Feed Roller

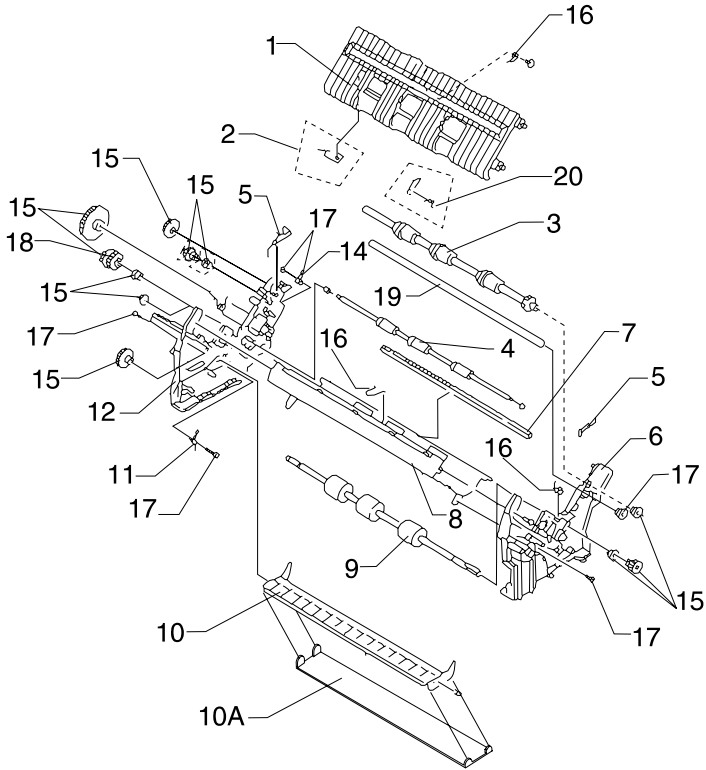

Asm-Index	Part Number	Description
4 -1	79F4803	Paper Guide/Platen Assembly (2380/2390-001)
1	1333231	Paper Guide/Platen Assembly (2380/2390-002, 003)
1	1333232	Paper Guide/Platen Assembly (2381/2391-001)
1	1333232	Paper Guide/Platen Assembly (2381/2391-002, 003)
2	79F4786	Paper Empty Sensor
3	79F4798	Feed Roller (Upper) (2380-001 & 2390-001)
3	79F4831	Feed Roller (Upper) (2381-001 & 2391-001)
3	1333226	Feed Roller (Upper) (2380-002, 003 & 2390-002, 003)
3	1333227	Feed Roller (Upper) (2381-002, 003 & 2391-002, 003)
4	79F4799	Pinch Roller (Lower) (2380 & 2390)
4	79F4832	Pinch Roller (Lower) (2381 & 2391)
5	79F4808	Pull Tractor Actuator Kit
6	1180927	Side Frame (Right) with Slider Cam (23XX-001, 002)
6	11A3312	Side Frame (Right) (23XX-003)
7	79F4802	Ribbon Drive Rack Gear (2380 & 2390)
7	79F4834	Ribbon Drive Rack Gear (2381 & 2391)
8	1368031	Carrier Plate (2380 & 2390)
8	1368032	Carrier Plate (2381 & 2391)
9	79F4801	Feed Roller (Lower) (2380 & 2390)
9	79F4833	Feed Roller (Lower) (2381 & 2391)
10	79F4809	Paper Separator (2380 & 2390)
10	79F4839	Paper Separator (2381 & 2391)
10A	1368003	Label Guide Bar (2380 & 2390)
10A	1368004	Label Guide Bar (2381 & 2391)
11	79F4788	Paper Select Sensor
12	79F4812	Side Frame (Left) (23XX-001)
12	1333233	Side Frame (Left) (23XX-002)
12	11A3345	Side Frame (Left) (23XX-003)
14	79F4787	Pull Tractor Sensor

Assembly 4: Paper Guide / Platen / Feed Roller (Cont.)

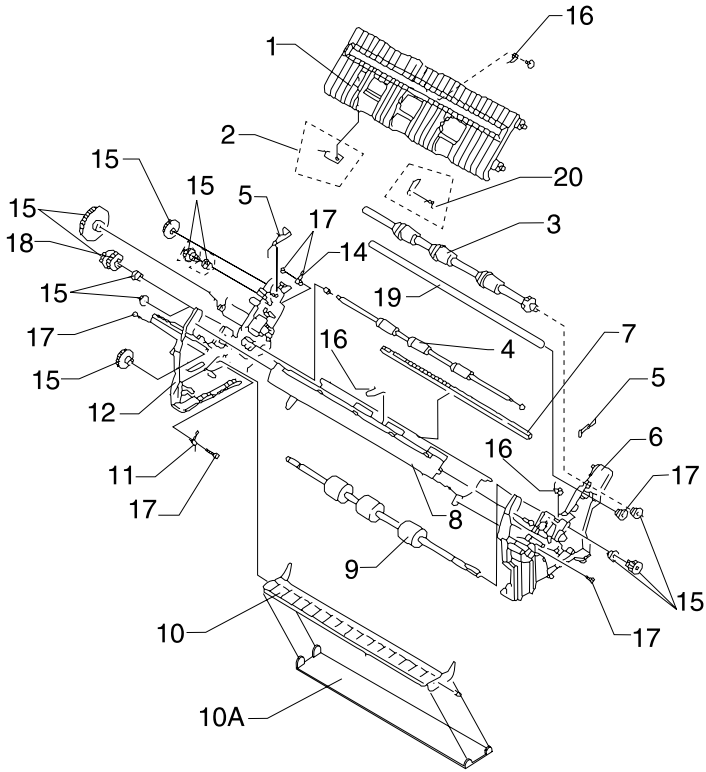

Asm-Index	Part Number	Description
4 -15	79F4810	Gear and Bushing Kit (2380-001, 002 & 2381-001, 002)
15	79F4806	Gear and Bushing Kit (2390-001, 002 & 2391-001, 002)
15	11A3272	Gear and Bushing Kit (238X-003)
15	11A3273	Gear and Bushing Kit (239X-003)
16	79F4811	Spring Kit (23XX-001, 2381-002, 2391-002)
16	1333228	Spring Kit (2380-002 & 2390-002)
16	11A3308	Spring Kit (2380-003 & 2390-003)
16	11A3309	Spring Kit (2381-003 & 2391-003)
17	79F4860	Screw, Washer, and Clip Kit (23XX-001)
17	1333219	Screw, Washer, and Clip Kit (23XX-002)
17	11A3344	Screw, Washer, and Clip Kit (23XX-003)
18	95F3675	Idler Gear (238X-001, 002)
18	95F3676	Idler Gear (239X-001, 002)
18	11A3274	Idler Gear (238X-003)
18	11A3275	Idler Gear (239X-003)
19	1333238	Frame Support Shaft (2380-002, 003 2390-002, 003)
19	1333239	Frame Support Shaft (2381-002, 003 2391-002, 003)
20	1333240	Top of Form Sensor (2380-002, 003 2390-002, 003)
20	1333241	Top of Form Sensor (2381-002, 003 2391-002, 003)

Assembly 5: Electronics

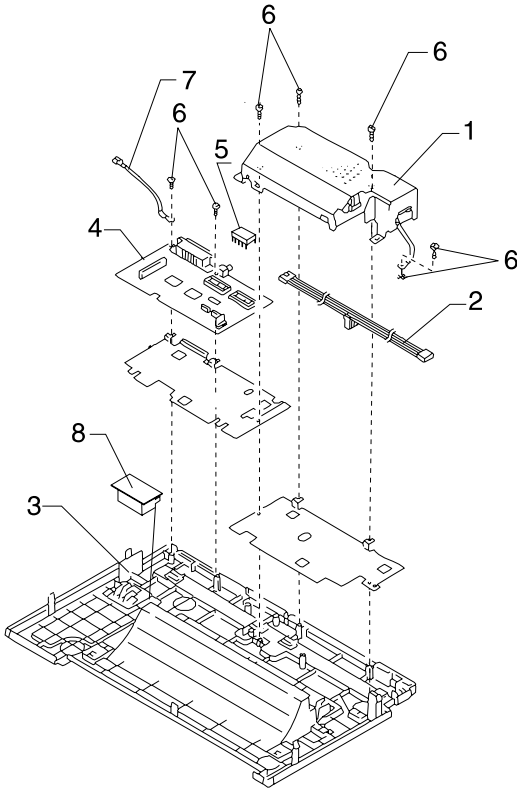

Asm-Index	Part Number	Description
5 -1	79F4755	Power Supply Unit (100-127 V ac, 23XX-001)
1	1333242	Power Supply Unit (100-127 V ac, 23XX-002, 003)
1	79F4756	Power Supply Unit (200-240 V ac, 23XX-001)
1	1333243	Power Supply Unit (200-240 V ac, 23XX-002, 003)
NS	1368071	Fuse Kit, Power Supply, all LVPS
NS	1333268	Fuse Kit, Power Supply, HVPS (23XX-001)
NS	1333269	Fuse Kit, Power Supply, HVPS (23XX-002, 003)
2	79F4815	Power Supply Cable (2380 & 2390)
2	79F4850	Power Supply Cable (2381 & 2391)
3	79F4776	Base (2380-001 LV)
3	79F5217	Base (2380-001 HV)
3	79F4777	Base (2381-001 LV)
3	79F5218	Base (2381-001 HV)
3	79F4822	Base (2390-001 LV)
3	79F4844	Base (2390-001 HV)
3	79F4823	Base (2391-001 LV)
3	79F5245	Base (2391-001 HV)
3	1333206	Base (2380-002, 003 2390-002, 003)
3	1333207	Base (2381-002, 003 2391-002, 003)
3	1180962	Base (2390 PS/1)
4	1180968	Main Logic Board W/ EPROM (2380-001 LV)
4	1180969	Main Logic Board W/ EPROM (2380-001 HV)
4	1333252	Main Logic Board W/ EPROM (2380-002 LV)
4	1333256	Main Logic Board W/ EPROM (2380-002 HV)
4	1180970	Main Logic Board W/ EPROM (2381-001 LV)
4	1180971	Main Logic Board W/ EPROM (2381-001 HV)
4	1333254	Main Logic Board W/ EPROM (2381-002 LV)
4	1333258	Main Logic Board W/ EPROM (2381-002 HV)
4	1180991	Main Logic Board W/ EPROM (2390-001 LV, 2390 PS/1)
4	1180992	Main Logic Board W/ EPROM (2390-001 HV)

Assembly 5: Electronics (Continued)

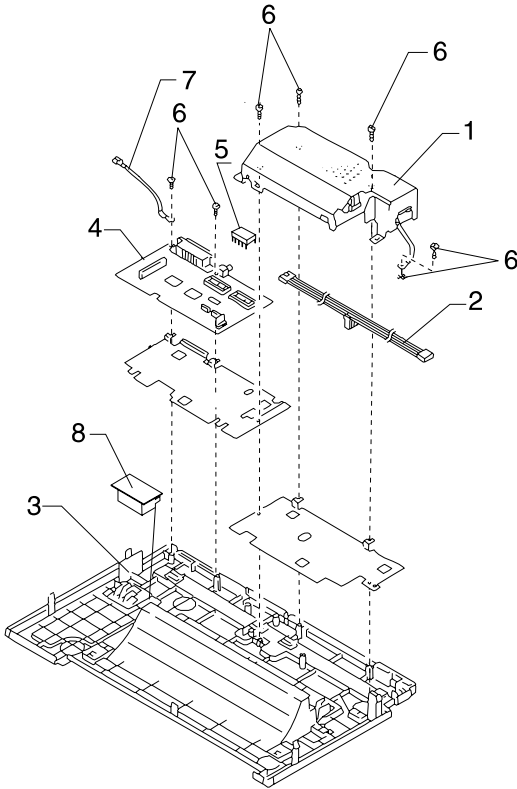

Asm-Index	Part Number	Description
5 -4	1333260	Main Logic Board W/ EPROM (2390-002 LV)
4	1333264	Main Logic Board W/ EPROM (2390-002 HV)
4	1180993	Main Logic Board W/ EPROM (2391-001 LV)
4	1180994	Main Logic Board W/ EPROM (2391-001 HV)
4	1333262	Main Logic Board W/ EPROM (2391-002 LV)
4	1333266	Main Logic Board W/ EPROM (2391-002 HV)
4	1368012	Main Logic Board W/ EPROM, Variable Forms Length (2380-001 LV)
4	1368013	Main Logic Board W/ EPROM, Variable Forms Length (2380-001 HV)
4	1368014	Main Logic Board W/ EPROM, Variable Forms Length (2381-001 LV)
4	1368015	Main Logic Board W/ EPROM, Variable Forms Length (2381-001 HV)
4	1368007	Main Logic Board W/ EPROM, Variable Forms Length (2390-001 LV)
4	1368008	Main Logic Board W/ EPROM, Variable Forms Length (2390-001 HV)
4	1368016	Main Logic Board W/ EPROM, Variable Forms Length (2391-001 LV)
4	1368017	Main Logic Board W/ EPROM, Variable Forms Length (2391-001 HV)
4	11A3322	Main Logic Board W/O EPROM (2380-003 LV)
4	11A3324	Main Logic Board W/O EPROM (2380-003 HV)
4	11A3323	Main Logic Board W/O EPROM (2381-003 LV)
4	11A3325	Main Logic Board W/O EPROM (2381-003 HV)
4	11A3326	Main Logic Board W/O EPROM (2390-003 LV)
4	11A3328	Main Logic Board W/O EPROM (2390-003 HV)
4	11A3327	Main Logic Board W/O EPROM (2391-003 LV)
4	11A3329	Main Logic Board W/O EPROM (2391-003 HV)
NS	11A3330	EPROM Kit (238X-003)
NS	11A3331	EPROM Kit (239X-003)

Assembly 5: Electronics (Continued)

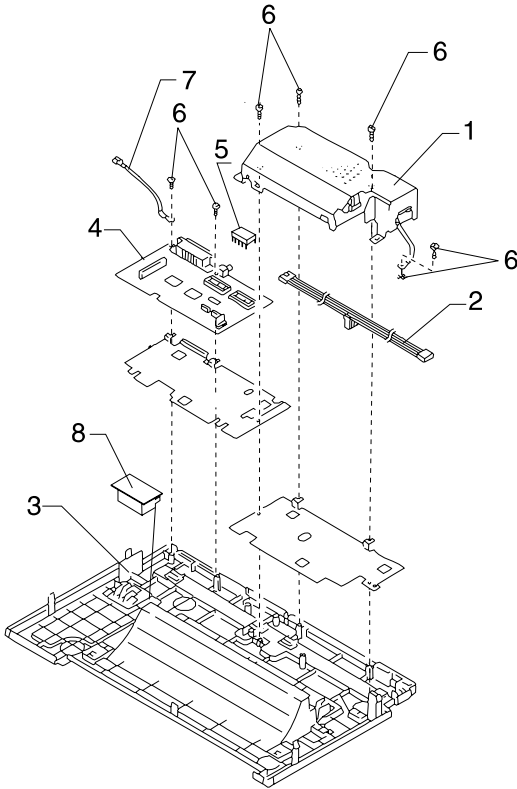

Asm-Index	Part Number	Description
5- 5	1180725	32Kb NVRAM Memory Module (Option)
5	1180727	32Kb Memory Module US (Option)
5	1180960	Extended NLS Module, EMEA (Option) (238X-001)
5	1180961	Extended NLS Module, EMEA (Option) (239X-001)
5	1332985	Extended NLS Module, Turkish/Greek (Option) (238X-002)
5	1332986	Extended NLS Module, Eastern Countries (Option) (238X-002)
5	1332987	Extended NLS Module, Middle East Countries (Option) (238X-002)
5	1332988	Extended NLS Module, Turkish/Greek (Option) (239X-002)
5	1332989	Extended NLS Module, Eastern Countries (Option) (239X-002)
5	1332990	Extended NLS Module, Middle East Countries (Option) (239X-002)
5	11A3285	Extended NLS Module, Eastern Europe (Option) (238X-003)
5	11A3286	Extended NLS Module, Eastern Europe (Option) (239X-003)
5	11A3287	Extended NLS Module, Middle East Countries (Option) (238X-003)
5	11A3288	Extended NLS Module, Middle East Countries (Option) (239X-003)
6	79F4860	Screw, Washer, and Clip Kit (23XX-001)
6	1333219	Screw, Washer, and Clip Kit (23XX-002)
6	11A3344	Screw, Washer, and Clip Kit (23XX-003)
7	79F4811	Spring Kit (23XX-001, 2381-002, 2391-002)
7	1333228	Spring Kit (2380-002 & 2390-002)
7	11A3308	Spring Kit (2380-003 & 2390-003)
7	11A3309	Spring Kit (2381-003 & 2391-003)
8	1368019	Rubber Board Support

Assembly 6: ASF - Roller / Support

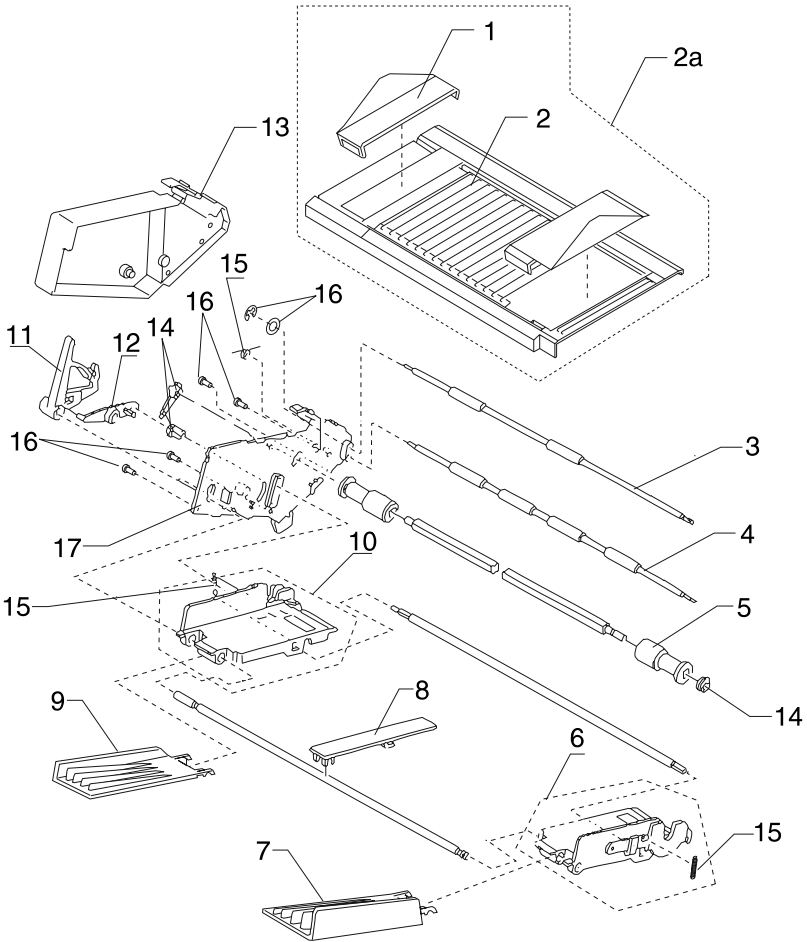

Asm-Index	Part Number	Description
6 -1	95F6884	Paper Guide(23XX-001,002, 2380-003, 2390-003)
2	95F6883	Cut Sheet Support (2380 & 2390)
2	95F6895	Cut Sheet Support (2381-001, 002 & 2391-001,002)
2A	11A3334	Cut Sheet Support W/ Guides (2381-003, 2391-003)
3	95F6886	Feed Roller Upper (2380 & 2390)
3	95F6896	Feed Roller Upper (2381 & 2391)
4	95F6887	Feed Roller Lower (2380 & 2390)
4	95F6897	Feed Roller Lower (2381 & 2391)
5	1333275	Pick-up Roller (L & R) (2381-003, 2391-003)
5	95F6885	Pick-up Roller (All others)
6	95F6889	Hopper (R)
7	1333278	Paper Support (R) (2381-003, 2391-003)
7	95F6879	Paper Support (R) (All others)
8	95F6880	Paper Support (C) (2381 & 2391)
9	95F6878	Paper Support (L)
10	1333280	Hopper (L) (2381-003, 2391-003)
10	95F6888	Hopper (L) (All others)
11	1333161	Paper Load Lever (2381-003, 2391-003)
11	95F6890	Paper Load Lever (All others)
12	1333162	Paper Load Link (2381-003, 2391-003)
12	95F6891	Paper Load Link (All others)
13	95F6881	Cover (L)
14	95F6892	Gear and Bushing Kit, ASF
15	95F6893	Spring Kit, ASF
16	95F6894	Screw Kit, ASF
17	95F6898	Side Frame (L)

Assembly 7: ASF - Side Frame / Covers

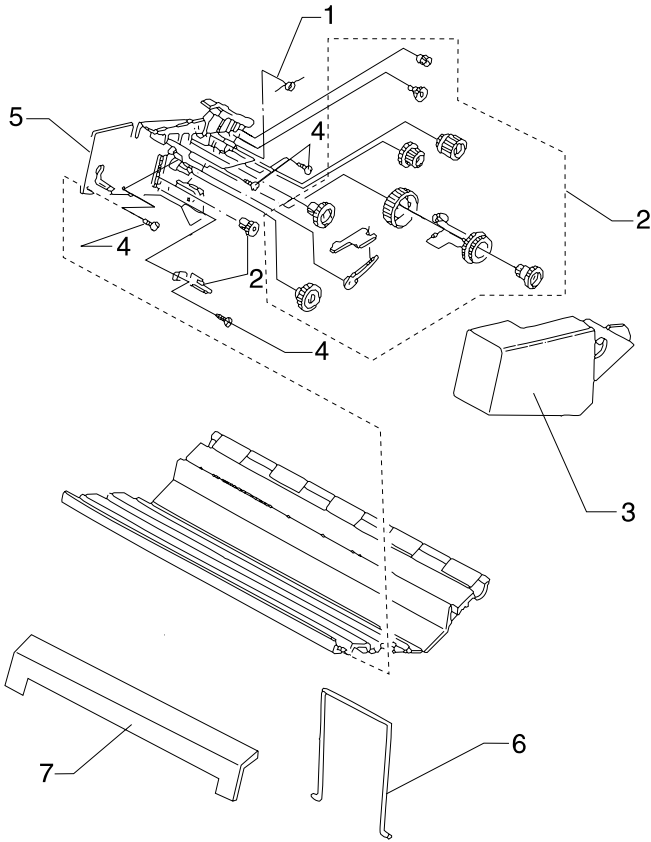

Asm-Index	Part Number	Description
7 -1	95F6893	Spring Kit, ASF
2	95F6892	Gear and Bushing Kit, ASF
3	95F6882	Cover (R)
4	95F6894	Screw Kit, ASF
5	95F6899	Side Frame (R)
6	95F6901	Stacking Support
7	95F6902	Front Cover (2380 & 2390)
7	95F6903	Front Cover (2381 & 2391)

Assembly 8: Tractor 2 Option

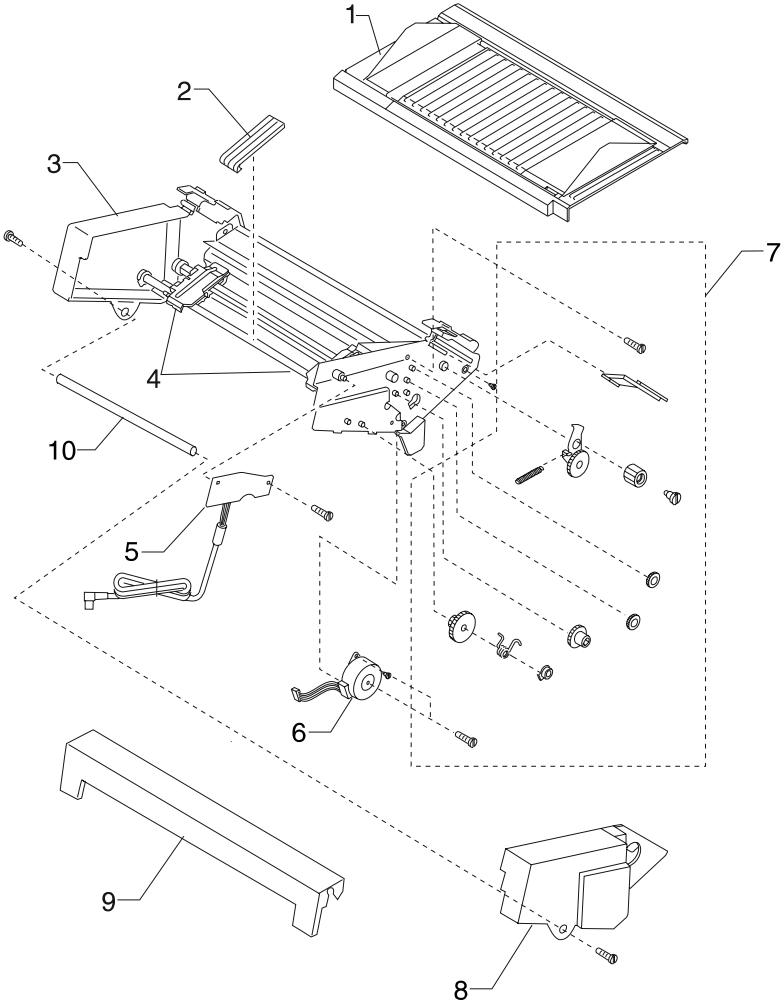

Asm-Index	Part Number	Description
8 -1	11A3342	Paper Table W/ Guides, Narrow
1	11A3343	Paper Table W/ Guides, Wide
2	11A3338	Tractor Paper Guide
3	11A3339	Tractor and Frame Asm, Narrow
3	11A3340	Tractor and Frame Asm, Wide
4	1333160	Tractor Kit (L & R)
5	11A3335	Board Asm W/Cable and Ferrite, Narrow
5	11A3336	Board Asm W/Cable and Ferrite, Wide
6	11A3337	Motor
7	11A3341	Parts Packet
8	11A3332	Right Cover
9	95F6902	Front Cover, Narrow
9	95F6903	Front Cover, Wide
10	11A3283	Support Shaft, Narrow
10	11A3284	Support Shaft, Wide

Index

A

- Abbreviations 1-5
- Adjustments 4-2
 - Bidirectional Print 4-5
- ASF
 - Principles of Operation 2-15

B

- Bidirectional Print Adjustment 4-5

C

- Connector Locations 5-1

E

- ESD-sensitive parts 4-1

I

- Irrecoverable Operator Errors
 - Paper Empty Sensor 2-13
 - Paper Select Sensor 2-13

L

- Lubrication 6-1

M

- Models available 1-1

O

- Operator Errors
 - Irrecoverable 2-13

P

- Parts
 - Auto Sheet Feeder
 - Covers 7-28
 - Roller 7-26
 - Side Frame 7-28
 - Support 7-26
 - Carrier 7-10
 - Covers 7-6, 7-8
 - Electronics 7-20
 - Feed Roller 7-16
 - Paper Guide 7-16
 - Platen 7-16
 - Tractor 2 Option 7-30
- Parts catalog
 - How to use 7-1
- Preventive Maintenance 6-1
 - Lubrication 6-1
 - Lubrication Points 6-2

- Specified Lubricants 6-1

R

- Removal Procedures 4-7
- Removals
 - ASF Pick-up Roller 4-9
 - Auto Sheet Feeder Gears 4-8
 - Bottom Cover 4-10
 - Carrier 4-12
 - Carrier Motor Assembly 4-16
 - Carrier Plate 4-18
 - Download Buffer 4-21
 - Form Thickness Lever 4-22
 - Head Gap Sensor
 - 23XX-002 4-24
 - 238X-001 4-23
 - Home Position Sensor 4-25
 - Jammed Label 4-26
 - Label Jam 4-26
 - Left Side Frame 4-28
 - Lower Feed Roller 4-30
 - Main Logic Board 4-33
 - Operator Panel 4-34
 - Paper Empty Sensor 4-36
 - Paper Empty Spring 4-36
 - Paper Feed Motor 4-38
 - Paper Guide/Platen 4-40
 - Paper Select Lever 4-42
 - Paper Select Sensor 4-43
 - Paper Separator 4-44
 - Pinch Roller (Lower) 4-32
 - Power Supply 4-46
 - Print Buffer 4-21
 - Print Unit 4-47
 - Printhead 4-48
 - Printhead Cables 4-49
 - Pull Tractor Actuator 4-51
 - Pull Tractor Sensor 4-52
 - Push Tractor Assembly 4-53
 - Ribbon Drive Rack Gear 4-54
 - Right Side Frame 4-56
 - Side Frame (Right) Gears 4-58
 - Sub Logic Card 4-59
 - Tension Pulley Plate 4-60
 - Top Cover 4-61
 - Top of Form Sensor 4-64
 - Top of Form Sensor Flag 4-64
 - Top of Form Spring 4-64
 - Upper Feed Roller 4-66

S

- Serial Interface
 - Adapters 1-7
 - Switches 1-8
- Service Checks

Abnormal Noise	2-14
Abnormal Print	2-23
Auto Sheet Feeder	2-15
Carrier Drive	2-17
Home Position Sensor	2-17
Intermittent Problem	2-20
No Print	2-23
Operator Panel	2-24
Paper Empty Sensor	2-26
Paper Feed	2-27
Paper Select Sensor	2-30
POST	2-31
Power	2-32
Print Speed	2-34
Printhead	2-36
Pull Tractor Sensor	2-38
Ribbon Feed	2-17
Top of Forms Problem	2-39
Tractor 2	2-40
Setup Mode	1-6
Symptom Checks	
Abnormal Indications	2-6
Abnormal Noise Problems	2-6
Abnormal Print Problems	2-7
ASF Problems	2-7
Error Indications	2-8
Operator Panel Problems	2-10
Paper Feed Problems	2-8
Power Problems	2-10
Print Quality Problems	2-11