

## Replacing the Printhead

1. Set the printer power switch to O (Off).

**WARNING** Always unplug the printer power cord from the printer or power outlet before doing any installation procedure. Failure to remove power could result in injury to you and damage the equipment. When applicable, you will be instructed to apply power.

2. Unplug the printer power cord from the printer or the AC power source.
3. Disconnect the data signal cable(s) from the printer interface(s).
4. Remove the ribbon and media (e.g., paper, label, or tag stock material).

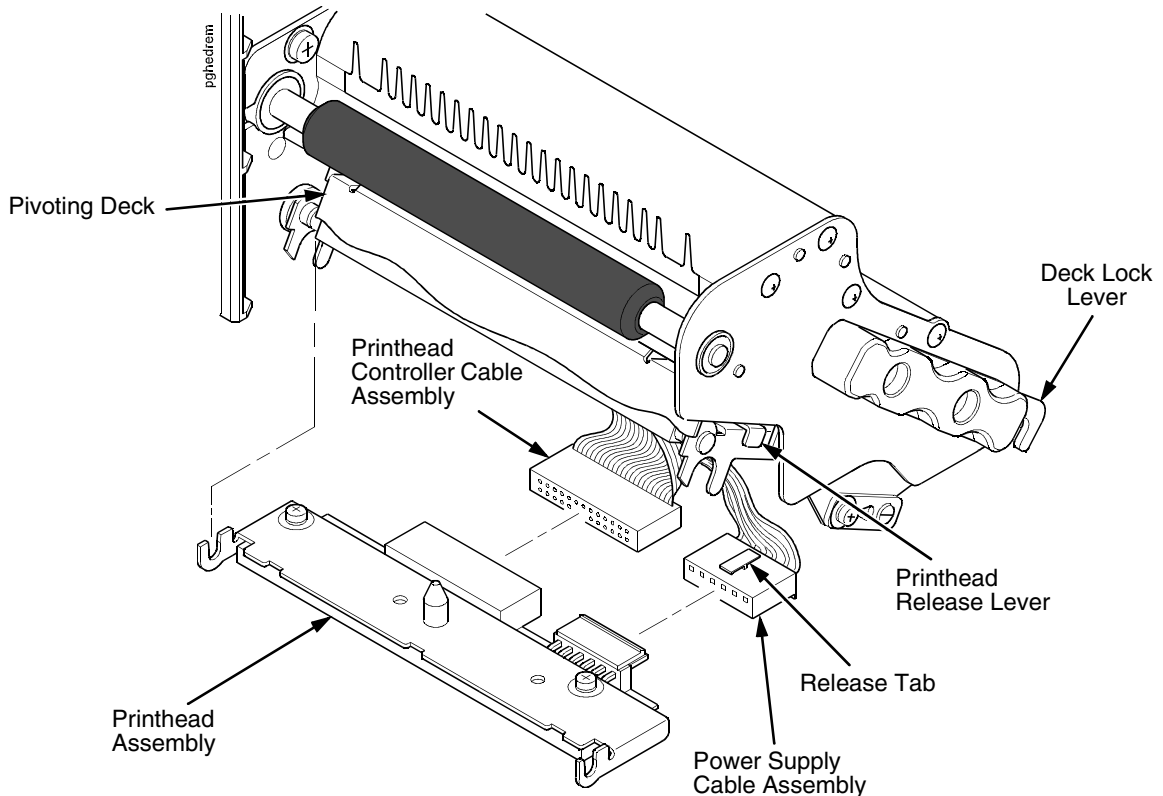

**Figure 4. Replacing the Printhead Assembly**

**CAUTION** Oils from your hands can damage the light brown area (heating elements) of the printhead. Do not touch the light brown area when you handle the printhead assembly.

5. Open the pivoting deck by rotating the deck lock lever fully counterclockwise. The pivoting deck will swing upward, exposing the bottom of the printhead assembly.

**CAUTION** To prevent electrostatic damage to electronic components, ground yourself by touching an unpainted part of the printer frame before handling and installing the printhead.

6. Touch an unpainted part of the printer frame before touching the printhead.
7. Press the printhead release lever and lower the old printhead.
8. Push the release tab down on the power supply cable assembly and remove the cable from the printhead assembly.
9. Remove the printhead controller cable assembly from the printhead assembly.

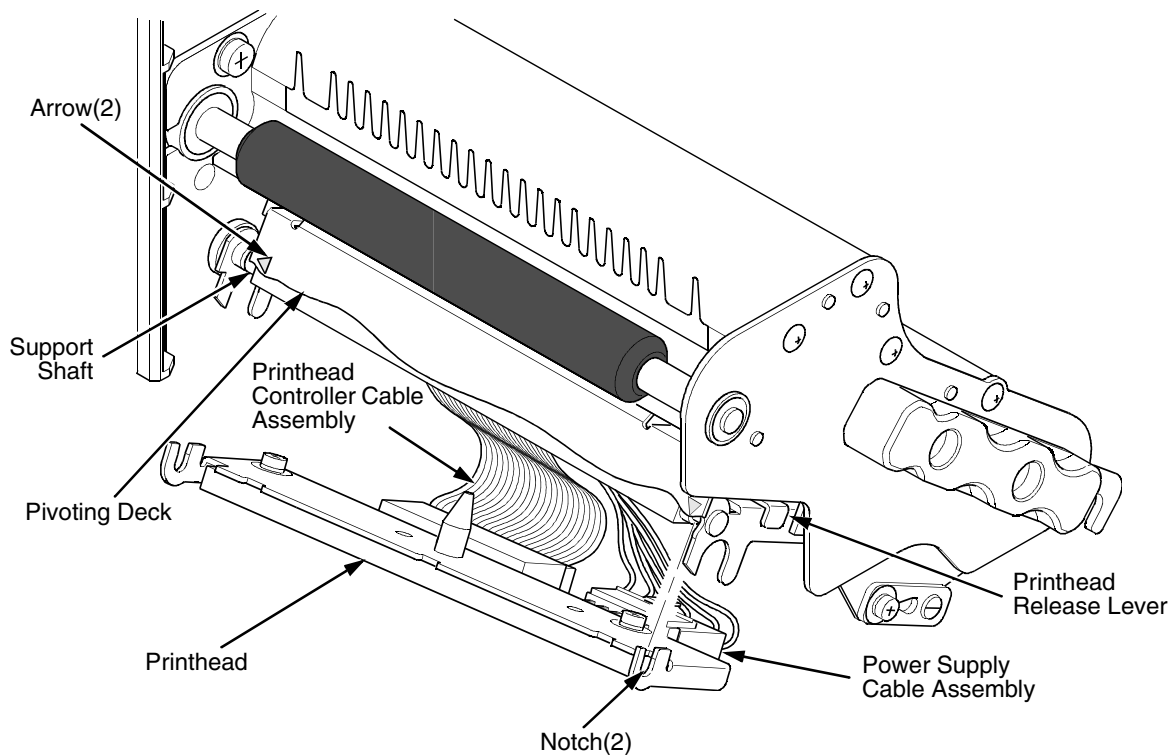

10. Position the new printhead below the pivoting deck and connect the printhead controller and power supply cable assemblies.
11. Lift the printhead upward into the pivoting deck.
12. Align the left printhead notch with the arrow on the left side of the pivoting deck and snap it onto the support shaft.
13. Align the right printhead notch with the arrow on the right side of the pivoting deck and snap it onto the support shaft.
14. Make sure that the cable assemblies do not extend past the printhead cover and into the media or ribbon path.
15. Align the new printhead (see “Media Thickness Adjustment” on page 41 or “Printhead Alignment” on page 43).